

# TOA NEW 900 SERIES MIXER POWER AMPLIFIER

A-901A



## Features

- 1 3-channel mixer power amplifier
- 2 Wide frequency response; 20 — 20,000 Hz,  $\pm 1$ dB
- 3 Low distortion and noise level
- 4 Excellent output regulation
- 5 Bass and treble controls on Input #1 and Program Input
- 6 Incorporated muting circuit
- 7 Self-protecting circuitry design
- 8 A full range of plug-in modules
- 9 Varied output impedances; 4 and 8 ohms, 25 and 70 volts
- 10 Clipping indicator
- 11 Compactness and lightweight
- 12 Portable or rack-mounting type

## General Description

The TOA A-901A Mixer Power Amplifier controls and mixes up to three independent input signals. Producing 10 watts of power, the A-901A has ideal flexibility for small sound reinforcement systems. Optional accessory modules are available for use with the A-901A to provide versatility for a wide range of operating applications. Edge connectors on the rear of the unit permit the selection of TOA plug-in modules : The H-01 series, H-02 series and H-03 series Microphone Preamplifiers, the E-01 Mag. Phono Preamplifier, the X-01 series Auxiliary Preamplifiers for high-level sources, the B-01 series Bridging Transformers for bridging high-impedance lines, the L-01 series Line Matching Transformers for matching 600-ohm lines, the I-01 Paging Input for combining with TOA Intercom Systems EXES-1000, EXES-5000 and EX-16, and the S-01, S-02 and S-03 Tone Signal Generators for generating attention-getting signals and 1kHz sine wave for testing within the total system. Other features include a muting function. Sources fed to Program Input and Input 1 are simultaneously muted by short-circuiting at MUTE TERMINAL on the rear. Accordingly, Input 2 can have priority. The TOA A-901A Mixer Power Amplifier has transformer-isolated output terminals to match 4- or 8-ohm speaker systems, or speaker distribution systems may be connected to the 25 or 70-volt terminals.

The A-901A can be rack mounted by using the MB-920 Rack-mounting Bracket Accessory.

# TOA NEW 900 SERIES

## Front Panel Controls and Features

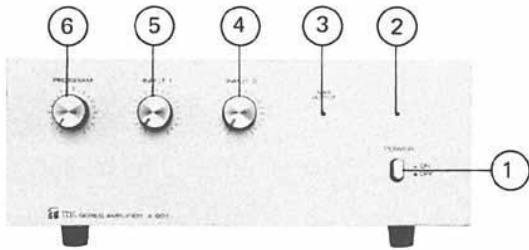

Item	Name	Function/Description
1	<b>POWER ON-OFF SWITCH</b>	Applies line power. Two-position pushbutton switch for on-off modes.
2	<b>POWER INDICATOR (LED)</b>	Illuminates when power is on. Green light-emitting diode.
3	<b>MAX. OUTPUT INDICATOR (LED)</b>	Turns to red when the output exceeds just above the power rating. If continuous clipping prevails, appropriate volume controls should be adjusted until indicator remains extinguished.
4	<b>VOLUME CONTROL for INPUT #2</b>	Adjusts gain of INPUT #2. Turn clockwise (CW) to increase gain.
5	<b>VOLUME CONTROL for INPUT #1</b>	Adjusts gain of INPUT #1. Turn CW to increase gain.
6	<b>PROGRAM INPUT VOLUME CONTROL</b>	Adjusts gain of PROGRAM INPUT. Turn CW to increase gain.

## Rear Panel Controls and Features

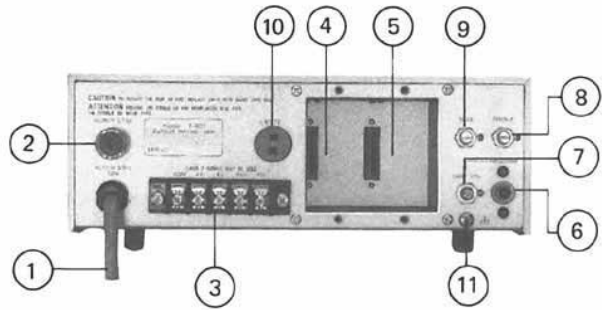

Item	Name	Function/Description
1	<b>AC POWER SUPPLY CORD</b>	Connects to power source.
2	<b>AC FUSE (250V, 0.75A)</b>	Protects amplifier from excessive current drain. Replace only with same type fuse. Refer to qualified service personnel if fuse blows repeatedly.
3	<b>OUTPUT TERMINALS</b>	Provide connections for speakers. (See page 2)
4	<b>MODULE INPUT PORT (INPUT #2)</b>	Accepts one plug-in input module accessory. Module selection is determined by application.
5	<b>MODULE INPUT PORT (INPUT #1)</b>	Accepts one plug-in input module accessory. Module selection is determined by application.
6	<b>PROGRAM INPUT</b>	Serves as auxiliary input to accept SCA tuner, etc.
7	<b>INPUT LIMIT VOLUME CONTROL</b>	Preadjusts gain of PROGRAM INPUT to limit excessive input.
8	<b>TREBLE CONTROL</b>	Adjusts treble response on PROGRAM INPUT and INPUT #1. INPUT #2 is not influenced by this treble control. Turn clockwise (CW) to boost and counterclockwise (CCW) to attenuate high frequency. Tone is flat at center.
9	<b>BASS CONTROL</b>	Adjusts bass response on PROGRAM INPUT and INPUT #1. INPUT #2 is not influenced by this bass control. Turn CW to boost and CCW to attenuate low frequency. Tone is flat at center.
10	<b>MUTE TERMINAL</b>	By short-circuiting at this terminal the signals fed to PROGRAM INPUT and INPUT #1 are muted simultaneously. The signals fed to INPUT #2 are not muted.
11	<b>EARTH TERMINAL</b>	Normally connects to a record player's ground.

## Input Connections

- This unit has two inputs for PLUG-IN MODULES and a program input.
- Plug the modules into INPUT PORTS, sliding them between the guide rails, and secure each with two screws.

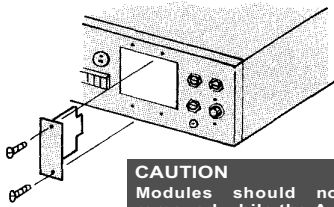

**CAUTION**  
Modules should not be inserted or removed while the A-901 A is turned on.

- When not all INPUT PORTS are occupied, cover the vacant PORTS with blank panels, and secure them with screws.
- INPUT MODULES are provided in the following:  
H-01, H-02, H-03, E-01, X-01, B-01, L-01, S-01, S-02, S-03  
\* See PLUG-IN MODULES for details.
- PROGRAM INPUT CONNECTION

RCA Phono Plug

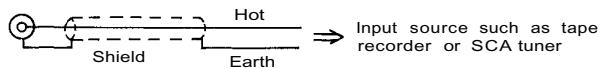

- MUTE SWITCH CONNECTION  
Connect a remote switch for MUTING to the MUTE TERMINAL.

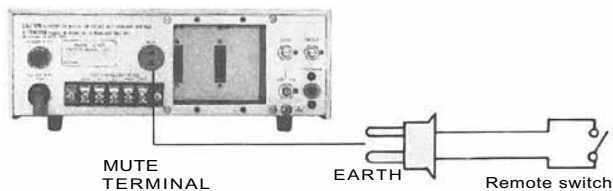

## Output Connections

Output transformer taps provide connections for 4-ohm and 8-ohm speakers, plus 70-volt (490-ohm) and 25-volt (62-ohm) speaker distribution outlets. Class 2 wiring may be used. Connect to the terminal of desired impedance and terminal COM (common).

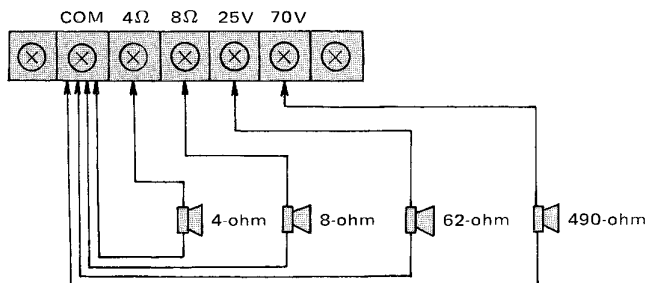

Note: Impedances indicated above imply total speaker system impedances.

## Operation

When all connections are completed, turn power switch on. The POWER INDICATOR (LED) lights green.

### ADJUSTMENT OF VOLUME

Adjust the individual input volume controls to obtain the desired operating level for respective inputs. If the output level is excessive, the MAX OUTPUT INDICATOR (LED) will momentarily light, in which case the gain of corresponding input should be reduced until this light no longer goes on.

### ADJUSTMENT OF TONE QUALITY

The tone quality of INPUT #2 is unadjustable but that of INPUT #1 and PROGRAM INPUT is adjustable.

Adjust the tone quality using the BASS and TREBLE CONTROLS (preadjustable) on the rear panel. Each of the controls provides frequency-response characteristics of boost and attenuation. Normal or flat response is obtained at center position. Turn CW to boost response.

## Installation

- Do not block the cover ventilation holes. The A-901 A should not be placed in areas;
  - 1 with poor ventilation.
  - 2 exposed to direct sunlight.
  - 3 with high ambient temperature or adjacent to heat-generating equipment.
  - 4 with high humidity or dusty levels.
  - 5 susceptible to vibration.

**CAUTION**  
Do not remove the case, or you may encounter an electric shock.

# TOA NEW 900 SERIES

## Rack Mounting

To mount the A-901A in a standard 19-inch equipment rack, use the MB-920 Rack-mounting Bracket accessory.

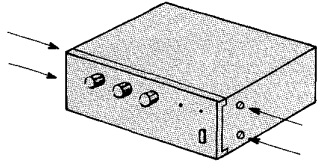

Remove 4 screws securing case.

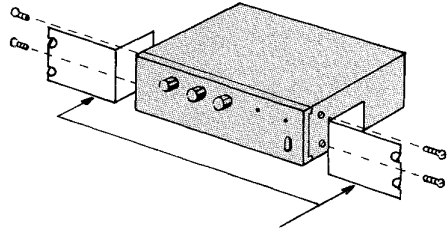

MB-920 (Silver)  
(OPTION)

Fix MB-920 with attached 4 screws.  
The length of the screws should not exceed 12mm (1/2 inches).

## Volume Control Cover

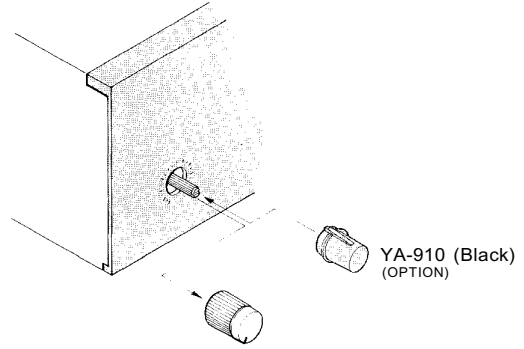

YA-910 (Black)  
(OPTION)

## Servicing

### ● Unpacking

Upon receipt of the amplifier shipment, please inspect for any damage incurred in transit. If damage is found, please notify your local TOA representative and the transportation company immediately.

State date, nature of damage, whether any damage was noticed on the shipping container, prior to unpacking. Please give waybill number of shipping order.

### ● Failure

Should amplifier fail, contact your nearest TOA authorized contractor or service center.

## Block Diagram A-901A

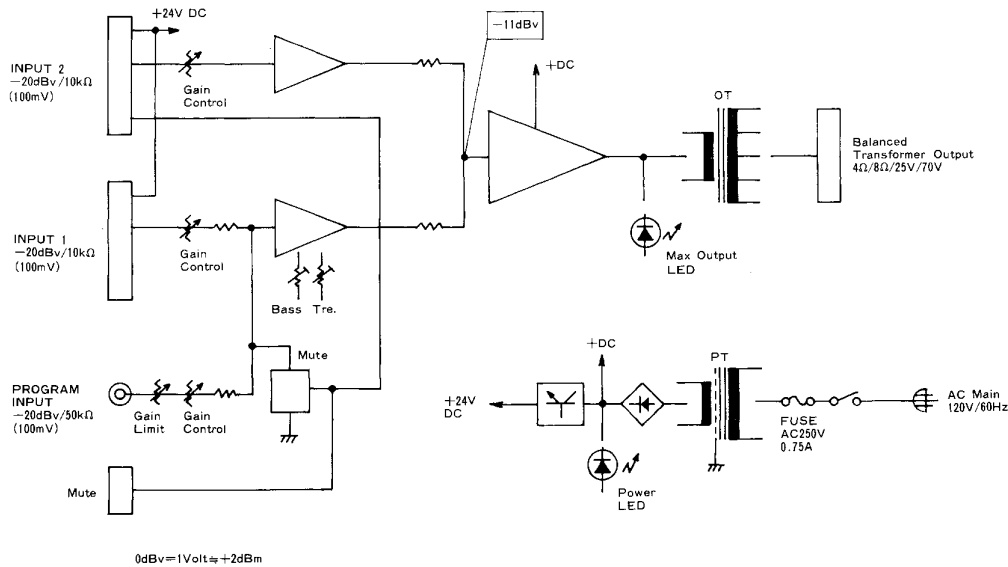

## Specifications A-901A

<b>Type</b>	<b>3-channel mixer power amplifier</b>
<b>Output Power</b>	10 watts RMS
<b>Power Band Width</b>	50 - 20,000 Hz 2% THD
<b>Frequency Response</b>	20- 20,000 Hz, $\pm 1$ dB
<b>Total Harmonic Distortion</b>	0.1% at 1 kHz, rated output
<b>Inputs</b>	Two Input Ports: Each port accepts any input module except T-01, which cannot be used. (T-01: Line Output Module) One Program Input
<b>Input Sensitivity/Impedance</b>	Input Ports #1 & #2: 100 mV/10k ohms Program Input : 100 mV/50k ohms
<b>Outputs (Transformer-isolated)</b>	Balanced 4,8 ohms, 25 & 70 volts
<b>Output Regulation (1 kHz)</b>	Less than 2.0 dB, no load to full load
<b>Signal to Noise Ratio (Band Pass 20 - 20,000 Hz) Tone Controls Centered</b>	All gain controls max.: 82 dB
<b>Tone Controls</b>	Bass; $\pm 10$ dB at 100 Hz: Treble; $\pm 10$ dB at 10k Hz Controls affect only input port #1 and program input.
<b>Controls</b>	2 Input gain controls 1 Program gain control 1 Program gain limit control 1 Bass tone control 1 Treble tone control 1 Power ON/OFF switch
<b>Indicators</b>	1 Power LED      1 Max. output LED
<b>Protection</b>	Self-protection, with 1 AC fuse
<b>Connectors</b>	Inputs #1 and #2 . . . . . Card-edge connector Program input . . . . . RCA phono jack Output . . . . . Screw terminal strip Mute . . . . . 2P socket AC power cord/plug . . . . . SJT, 3-prong type
<b>Power Consumption</b>	AC 120 volts, 60 Hz, 30 watts
<b>Temperature Range</b>	-10°C to +60°C (12°F to 140°F)
<b>Dimensions in mm (inches) (high) x (wide) x (deep)</b>	101 (3.98") x 250 (9.84") x 245 (9.65") Rack-mounting space size "2U" (3.46")
<b>Weight (without input modules)</b>	3.9 kg (8.6 lbs.)
<b>Color</b>	Silver
<b>Standard Accessory</b>	1 Mute terminal plug
<b>Other Features</b>	Program input and input port #1 muted simultaneously.

\* Specifications are subject to change without notice.

# TOA NEW 900 SERIES

## Plug-in Modules and Accessories

(OPTION)



The TOA PLUG-IN MODULES are suitable for TOA 900 SERIES MIXER POWER AMPLIFIERS A-901A, A-903A, A-906A, and A-912A MIXER PREAMPLIFIER M-900A, and POWER AMPLIFIERS P-906A, P-912A and P-924. Owing to wide selection of MODULES, the desired applications will be obtained. The various types of connectors can also meet the needs of equipment to be connected. MICROPHONE PREAMPLIFIER H-01 series, H-21 and H-31 incorporates controls for high-cut, low-cut and gain, H-02 series, H-22, H-32 and H-03 series controls for low-cut and gain. A gain control is built in MAG. PHONO PREAMPLIFIERS E-01 and E-11 series, AUXILIARY PREAMPLIFIERS X-01 and X-11 series and X-21, PAGING INPUT I-01 and LINE OUTPUT T-01 series. T-01 series is an output module with transformer, serving as a line output for recording, etc..









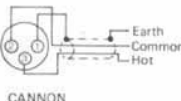
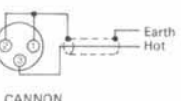

PAGING INPUT I-01 is specially designed to associate with TOA INTERCOM SYSTEMS. It accepts paging signals from the intercom station.

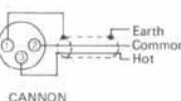
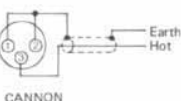
A group of special signal generating modules is also available for catching-attention before announcement and testing within the total system. ALL PLUG-IN MODULES have handles on their front for easy insertion and removal.

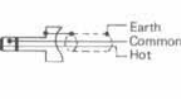
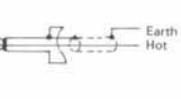
### Features:

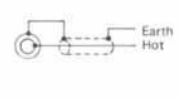
1. Wide dynamic range
2. Low noise and distortion
3. Wide frequency response
4. Built-in remote volume control circuit (available for models having 20's in its model number such as H-21)
5. Built-in muting circuit to mute incoming signal when MUTE TERMINAL is grounded, (available for modules having 10's in its model number such as X-11)
6. Built-in muting circuit to deliver output signal when MUTE TERMINAL is grounded, (available for modules having 30's in its model number such as H-31)
7. Built-in signal activated muting function (L-41)
8. Presettable gain control (except for B-01, B-11, L-01 and L-11)
9. Microphone modules furnished with tone controls (H-01, H-02, H-21, H-22, H-31, H-32 and H-03)

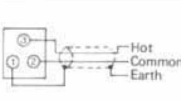
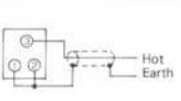
(INPUT CONNECTIONS, T-01 OUTPUT CONNECTION)

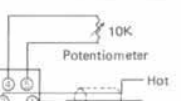
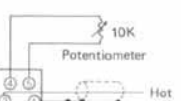
MODEL	PLUG-CONNECTIONS	
	Balanced Connection	Unbalanced Connection
Connection	H-01 series H-21 H-02 series H-22 B-01 series H-31 B-11 series H-32 L-01 series L-11 T-01 series L-41	H-03 series E-01 series E-11 series X-01 series X-11 series X-21
 CANNON XLR-3-13 (Female) type	 CANNON XLR-3-12 (Male) type	 CANNON XLR-3-12 (Male) type
 CANNON XLR-3-14 (Male) type	 CANNON XLR-3-11 (Female) type	 CANNON XLR-3-11 (Female) type
 Phone Jack (P)	 Phone Plug (Double Pole)	 Phone Plug (Single Pole)
 RCA Phono Jack (R)		 RCA Phono Jack
 3P Screw Terminal (S)	 Hot Common Earth	 Hot Earth
 5P Screw Terminal (S)	 10K Potentiometer Hot Common Earth	 10K Potentiometer Hot Earth

# TOA NEW 900 SERIES

## Plug-in Modules

Applications		Module Types	Source Impedance	Input Sensitivity for Rated Output (100 mV)	Gain	Max. Before Clip into 10k-ohm load at less than 0.5% THD (Output 1 kHz) [S-01, S-02, S-03]	Frequency Response ±1dB	Noise level (equivalent input noise or SIN)	Signal Muting Level	Remote volume control range (Use 10k-ohms potentiometer)	Controls (pre-settable)	Weight (max.)	XLR-3-19(F) Type	XLR-3-14(M) Type	Phone Jack (P)	RCA Phono Jack (S)	3P Screw Terminal(S)	5P Screw Terminal(S)
Low Z MIC with Low & High filters	with Low & High filters and remote volume control facilities	H-01 series	Balanced 200 ohms	nominal 1.0 mV adjustable 0.25-25 mV	nominal 40 dB adjustable 52-32 dB	6.3V(+16 dB)	25-20,000 Hz	-126 dBm/200 ohms terminated	60 dB	0-60 dB	1-Low cut 1-High cut 1-Gain	105 gr (3.71 oz)	H-01F	H-01M	H-01P	H-01S	H-01S	H-21S
		H-21	Balanced 200 ohms	nominal 1.0 mV adjustable 0.25-25 mV	nominal 40 dB adjustable 52-32 dB	6.3V(+16 dB)	25-20,000 Hz	-126 dBm/200 ohms terminated	60 dB	0-60 dB	1-Low cut 1-High cut 1-Gain	100 gr (3.53 oz)	H-02F	H-02M	H-02P	H-02S	H-02S	H-21S
Low Z MIC with Low & High filters and MUTE	with Low & High filters and remote volume control facilities	H-31	Balanced 200 ohms	nominal 1.0 mV adjustable 0.25-25 mV	nominal 40 dB adjustable 52-32 dB	6.3V(+16 dB)	25-20,000 Hz	-126 dBm/200 ohms terminated	60 dB	0-60 dB	1-Low cut 1-High cut 1-Gain	105 gr (3.70 oz)	H-02F	H-02M	H-02P	H-02S	H-02S	H-21S
		H-02 series	Balanced 200 ohms	nominal 1.0 mV adjustable 0.25-25 mV	nominal 40 dB adjustable 52-32 dB	6.3V(+16 dB)	25-20,000 Hz	-126 dBm/200 ohms terminated	60 dB	0-60 dB	1-Low cut 1-High cut 1-Gain	100 gr (3.53 oz)	H-02F	H-02M	H-02P	H-02S	H-02S	H-21S
Low Z MIC with Low-cut filter and remote volume control facilities	with Low-cut filter and MUTE	H-22	Balanced 200 ohms	nominal 1.0 mV adjustable 0.25-25 mV	nominal 40 dB adjustable 52-32 dB	6.3V(+16 dB)	25-20,000 Hz	-126 dBm/200 ohms terminated	60 dB	0-60 dB	1-Low cut 1-Gain	95 gr (3.35 oz)	H-02F	H-02M	H-02P	H-02S	H-02S	H-22S
		H-02 series	Balanced 200 ohms	nominal 1.0 mV adjustable 0.25-25 mV	nominal 40 dB adjustable 52-32 dB	6.3V(+16 dB)	25-20,000 Hz	-126 dBm/200 ohms terminated	60 dB	0-60 dB	1-Low cut 1-Gain	95 gr (3.35 oz)	H-02F	H-02M	H-02P	H-02S	H-02S	H-22S
High Z MIC with Low-cut filter	with Low-cut filter and MUTE	H-03 series	Unbalanced 50k ohms	nominal 3.2 mV adjustable 0.5-8.0 mV	nominal 30 dB adjustable 42-22 dB	6.3V(+16 dB)	20-20,000 Hz	SIN 70dB	—	1-Low cut 1-Gain	1-Low cut 1-Gain	60 gr (2.12 oz)	H-03P	H-03P	H-03P	H-03R	H-03S	—
		E-01 series	Unbalanced 50k ohms	nominal 3.2 mV adjustable 2.0-5.0 mV	nominal 34 dB adjustable 34-26 dB	6.3V(+16 dB)	RIAA Equalized	SIN 70dB	60 dB	—	1-Gain	1-Gain	50 gr (1.76 oz)	E-01R	E-01P	E-01P	E-01R	E-01S
Mag. Phono Preampifier	with MUTE with remote volume control facilities	X-01 series	Unbalanced 22k ohms	nominal 100 mV adjustable 100-3,200 mV	nominal 0 dB adjustable 0-30 dB	6.3V(+16 dB)	20-20,000 Hz	SIN 90dB	60 dB	0-60 dB	1-Gain	70 gr (2.47 oz)	X-01F	X-01M	X-01P	X-01S	X-01S	—
		X-11 series	Unbalanced 22k ohms	nominal 100 mV adjustable 100-3,200 mV	nominal 0 dB adjustable 0-30 dB	6.3V(+16 dB)	20-20,000 Hz	SIN 90dB	60 dB	0-60 dB	1-Gain	70 gr (2.47 oz)	X-11F	X-11M	X-11P	X-11S	X-11S	—
Auxiliary Preampifier	with remote volume control facilities	X-21	Balanced 10k ohms	125 mV	-1dB	—	20-20,000 Hz	—	60 dB	—	—	65 gr (2.29 oz)	—	—	—	—	—	X-21S
		B-01 series	Balanced 10k ohms	125 mV	-1dB	—	20-20,000 Hz	—	60 dB	—	—	—	90 gr (3.17 oz)	B-01F	B-01P	B-01P	B-01S	—
Bridging transformer	with MUTE with Signal Activating Mute	L-01 series	Balanced 600 ohms	nominal 3.2V adjustable 3.2-10V	nominal -30 dB adjustable 30-40 dB	—	20-20,000 Hz	—	60 dB	—	—	90 gr (3.17 oz)	L-01F	L-01M	L-01P	L-01S	L-01S	—
		L-11 series	Balanced 600 ohms	nominal 3.2V adjustable 3.2-10V	nominal -30 dB adjustable 30-40 dB	—	20-20,000 Hz	—	60 dB	—	—	—	90 gr (3.17 oz)	L-11F	L-11M	L-11P	L-11S	L-11S
Line Matching Transformer	with MUTE with Signal Activating Mute	L-41	Balanced 600 ohms	nominal 3.2V adjustable 3.2-10V	nominal -30 dB adjustable 30-40 dB	—	20-20,000 Hz	—	60 dB	—	—	95 gr (3.35 oz)	—	—	—	—	—	L-41S
		L-01	Balanced 600 ohms	nominal 3.2V adjustable 3.2-10V	nominal -30 dB adjustable 30-40 dB	—	20-20,000 Hz	—	60 dB	—	—	—	95 gr (3.35 oz)	—	—	—	—	—
Paging Input	with MUTE with Signal Activating Mute	T-01 series	Output Impedance 600 ohms	—	nominal 20 dB adjustable 20-4 dB [10V output] [10V(+16 dB)]	5.3V(+16 dB) into 600-ohm load	30-20,000 Hz	SIN 90 dB	—	—	—	100 gr (3.53 oz)	—	T-01M	—	—	—	T-01S
		S-01	—	—	—	nominal 20 dB adjustable 20-4 dB [10V(+16 dB)]	5.3V(+16 dB) into 600-ohm load	SIN 90 dB	—	—	—	55 gr (1.94 oz)	—	—	—	—	—	S-01S
Tone Signal Generator	1 kHz Sine Wave Buzzer/Chime	S-02	—	—	—	0.5V(-6 dB)/0.5% THD 1V peak to peak	—	SIN 80 dB	—	—	—	60 gr (2.12 oz)	—	—	—	—	—	S-02S
		S-03	—	—	—	—	0.5V(-6 dB)/0.5% THD 1V peak to peak	SIN 80 dB	—	—	—	70 gr (2.47 oz)	—	—	—	—	—	S-03S

\* 0dB= 1 volt + 2 dBm. Specifications are subject to change without notice.

### FORN PANEL CONTROLS AND FEATURES

Modules with built-in controls are provided in the following five types.

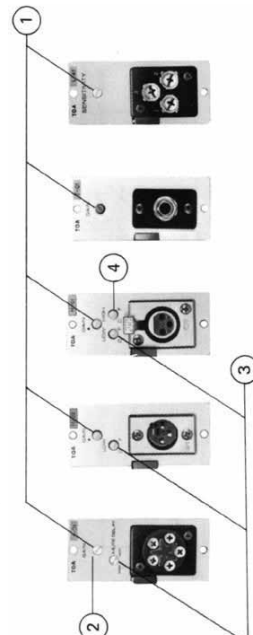

① **GAIN CONTROL** This adjusts gain. Turn clockwise (CW) to increase gain and counterclockwise (CCW) to reduce gain. Set the gain as low as possible, and the maximum noise can be reduced, and the maximum permissible input level is raised. This adjusts sensitivity for muting other modules having MUTE function. Turn CW to raise and CCW to lower sensitivity. Setting position should depend on the equipment connected with L-41S.

② **NOMINAL POSITION MARK** The left figure shows nominal setting of controls.

③ **LOW-CUT FILTER CONTROL 330Hz 6dB/oct (max. attenuation)** This provides flat characteristics at full CW position and attenuation in low frequency by turning CCW. Adjust it to obtain proper tone quality. With low-cut, tone becomes clear. This adjusts MUTE delay time which is the duration from signal input to the output. Turn CW to shorten and CCW to lengthen the time. This provides flat characteristics at full CW position and attenuation in high frequency by turning CCW. Adjust it to obtain proper tone quality. With high-cut, tone becomes soft.

④ **HIGH-CUT FILTER CONTROL (1-01S) 4.2kHz 6dB/oct (max. attenuation)** This provides flat characteristics at full CW position and attenuation in high frequency by turning CCW. Adjust it to obtain proper tone quality. With high-cut, tone becomes soft.

⑤ **MUTE DELAY CONTROL (1-01S)** This adjusts MUTE delay time which is the duration from signal input to the output. Turn CW to shorten and CCW to lengthen the time. This provides flat characteristics at full CW position and attenuation in high frequency by turning CCW. Adjust it to obtain proper tone quality. With high-cut, tone becomes soft.

### SPECIFICATIONS IN COMMON

Load impedance : 10k-ohms  
Mounting : Card-edge connector  
Dimensions in mm (inches) : 78(3.07)x35(1.38)x88(3.46)  
(H) x (W) x (D)

**CAUTION:**  
The A-901A does not accept the modules E-11, X-11, B-11, L-11 and T-01 series marked with slant lines.

# TOA NEW 900 SERIES

## Block Diagrams (Plug-in Modules)

<p><b>H-01 Series</b></p>	<p><b>B-01 Series</b></p>
<p><b>H-21S</b></p>	<p><b>B-11 Series</b></p>
<p><b>H-31S</b></p>	<p><b>L-01 Series</b></p>
<p><b>H-02 Series</b></p>	<p><b>L-11S</b></p>
<p><b>H-22S</b></p>	<p><b>L-41S</b></p>
<p><b>H-32S</b></p>	<p><b>T-01 Series</b></p>
<p><b>H-03 Series</b></p>	<p><b>S-01S</b></p>
<p><b>E-01 Series</b></p>	<p><b>S-02S</b></p>
<p><b>E-11 Series</b></p>	<p><b>S-03S</b></p>
<p><b>X-01 Series</b></p>	<p><b>I-01S</b></p>
<p><b>X-11 Series</b></p>	
<p><b>X-21S</b></p>	



# Operation and Connections (Plug-in Modules)

## • H-31 and H-32 (with mute)

### Connections

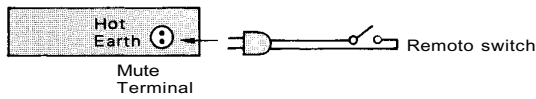

### Operation

- A built-in MUTE circuit of the A-901A mutes signals fed to both PROGRAM INPUT and INPUT PORT #1 at the same time when the above remote switch is closed.
- Ensure that the INPUT PORT #2 is used when mounting the H-31 or H-32 on the A-901A. Closing the remote switch causes signals fed to the H-31 or H-32 to be supplied to the power amplifier stage. (While the switch is opened, the signals are attenuated.)

### Performance of the MUTE circuit

MUTE Terminal	Signals fed to INPUT PORT #2 with H-31 or H-32	Signals fed to PROGRAM INPUT and INPUT PORT #1
Opened	Attenuated(Muted)	Supplied to the power amp stage
Closed	Supplied to the power amp stage	Attenuated (Muted)

## • L-41 (with signal activated muting facilities)

When this module accepts the input signal, the mute terminal is grounded automatically without connection of the remote switch to the MUTE TERMINAL. As a result, signals fed to both PROGRAM INPUT and INPUT PORT #1 are muted. Ensure that the INPUT PORT #2 is used when mounting the L-41 on the A-901. When installed into INPUT PORT #1, it does not work.

## • H-21, H-22 and X-21 (Remote volume control facilities)

### Connections

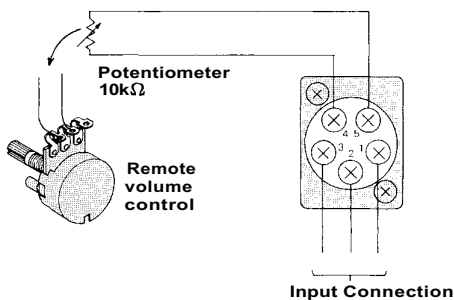

### Operation

Preset the gain control of module and the input volume control of the corresponding input so that an appropriate sound level may be obtained through the remote volume control.

### CAUTION

- Use the potentiometer of 10K ohms.
- Make wiring lest the interference from external noise should occur.

## • S-01 (1,000Hz SINE WAVE)

### Connections

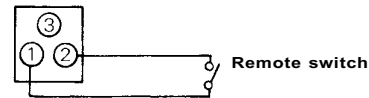

It is operated by closing the remote switch.

## • S-02 (YELP AND BUZZER)

### Connections

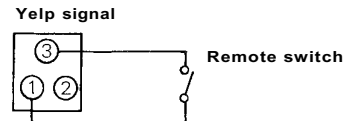

Each signal is generated by closing corresponding remote switch.

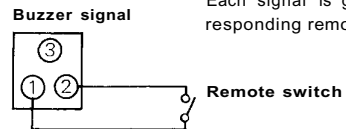

## • S-03 (ONE-TONE CHIME AND CONTINUOUS ONE-TONE CHIME)

### CONNECTIONS

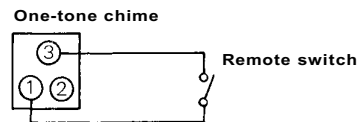

By closing the remote switch, chime sounds once.

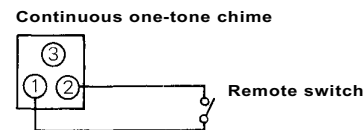

By closing the remote switch, one-tone chime sounds continuously during the closure of the switch.

# TOA NEW 900 SERIES

## Schematic A-901A

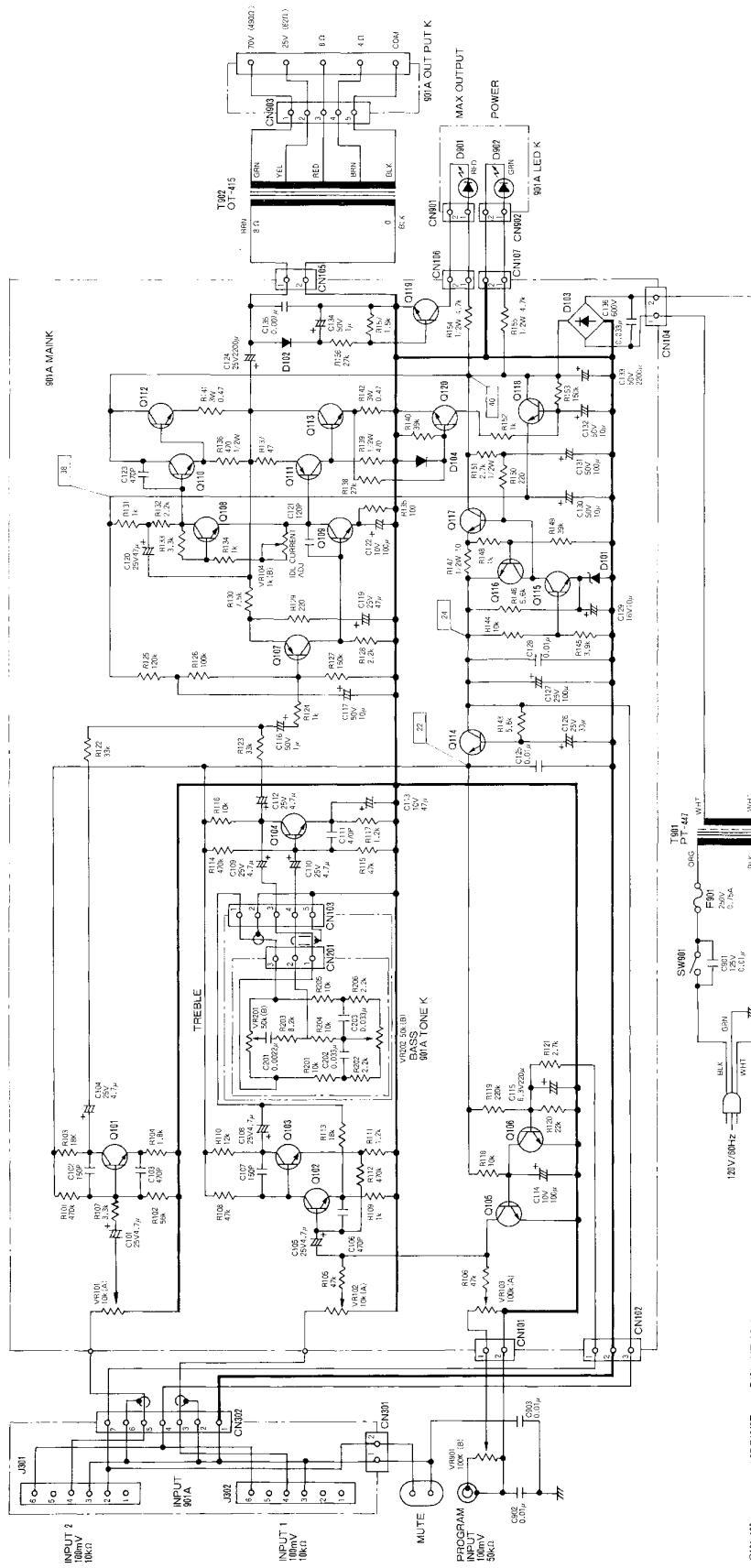

- O101, 102 : 25C134EE
- O103-108, 116, 118, 119 : 25C1510F
- O107 : 25A38NE
- O108 : 25C220GR
- O109 : 25C061AC
- O110 : 25C113AC
- O111 : 25A813AC
- O112, 113, 117 : 25C081E
- O114, 115 : 25C113C
- O118 : 25C151F
- D101 : HZ-9C-1
- D102 : IS18FEM
- D103 : SA1B10
- D104 : IS1213
- D105 : SLR-44VCA (LED/RED)
- D106 : SLR-44CCA (LED/GRN)

1. RESISTANCE VALUES IN OHMS
2. ALL RESISTORS 1/4W UNLESS OTHERWISE DESIGNATED
3. CAPACITANCE VALUES IN FARAD UNLESS OTHERWISE DESIGNATED
4. VOLTAGES ARE MEASURED TO CHASSIS GROUND WITH NO SIGNAL
5. ALL CAPACITORS 50V UNLESS OTHERWISE DESIGNATED

