

# Everything You (Really) Wanted to Know About the **9000M2** Series



## A User's Guide



Rev 1.1

# How To Use This Guide

First, congratulations on your choice of the TOA 9000M2 Series of Modular Mixer / Amplifiers. The 9000M2 Series is an evolutionary development in the critically-acclaimed 9000 Series and is one of the most versatile and cost-effective audio products available, designed to function in a myriad of mixing, paging and room-combining applications. However, as with many DSP-based products currently available, the 9000M2 Series does have a reasonable learning curve. This guide is not a substitute for operations manuals, but should be used in conjunction with them. It is being presented as a means of illuminating systems designers and installers, as well as end-users with a better understanding of how to make the most of the 9000M2 Series' potential. In short, it is designed to be your 9000M2 Series "survival kit". This will be a simple, concise guide on to how to configure, program and operate your 9000M2 Series unit. If you're reading this, perhaps it means you've tried sifting through chapters in the manual, spent countless hours staring at the front panel (or GUI) display and now you're engaged in pulling out hair follicles. You're probably just looking for some real-world answers to your questions. In this guide, we will explore (and answer) those questions together.

The Table of Contents is set up to easily find information about the 9000M2 by topic and by related questions.

Occasionally, there will be footnotes or vital information denoted by:

\*

*or by*



Please pay special attention to these, as they are meant to save you from confusion and unnecessary aggravation.

This guide is also intended to be a "living" document. As questions and challenges arise from installers and users alike, we will amend this guide to reflect them.

Lastly, there are links to various other resources at the end, which if used in conjunction with this guide, should make working with 9000M2 Series more productive.

***Well, let's go to it!***

# Table of Contents

	<u>Subject</u>	<u>Page</u>
	<b>What's Changed- Original 9000 vs. 9000M2</b> .....	5
<b>1.</b>	<b>Hardware Configuration (modules, accessories, etc.)</b>	
	a. What comes supplied with my 9000 Series unit?.....	6
	b. What state is the 9000 when first powered on?.....	6
	c. What function does each module perform?.....	7
	d. What modules go where?.....	9
	e. How can I tell which modules are installed if the 9000M2 is racked?.....	10
	f. What DSP functions are available in each module?.....	11
	g. When do I use this module?.....	12
	h. What if I need more inputs or outputs?.....	12
	i. What are the PRE OUT & AMP IN connections used for?.....	12
<b>2.</b>	<b>Getting Around the Front Panel Controls</b>	
	a. What do these buttons do?.....	13
	b. What do these indications on the display mean?.....	13
	c. How do I edit settings from the front panel?.....	14
<b>3.</b>	<b>Operating Layers (Read this.....REALLY!)</b>	
	a. What's the difference between the Scene & Paging memories?.....	15
	b. How does operation of these two layers differ?.....	15
	c. How do I save a Configuration to my PC?.....	16
<b>4.</b>	<b>Programming From the GUI</b>	
	a. How do I Get Started?.....	17
	Installing the GUI Software.....	17
	STEP 1. Start Menu.....	17
	STEP 2. Initial Setup Wizard-Module setup.....	18
	STEP 3. Initial Setup Wizard-Remote setup (1).....	19
	STEP 4. Initial Setup Wizard-Remote setup (2).....	20
	b. Mainframe Configuration Setting View.....	21
	c. Scene Memory View.....	22
	d. Volume Setting View.....	23
	e. EQ Setting View.....	24
	f. Compressor Settings View.....	25
	g. Gate/NOM Setting View.....	26
	h. Output Assignment View.....	27
	i. Delay Setting View.....	28
<b>5.</b>	<b>Paging Settings</b>	
	<i>How do I set the 9000M2 for priority paging?</i> .....	29
	a. Input Paging Priority Setting.....	29
	b. Paging Volume Setting.....	30
	c. Paging Settings.....	31
	d. How do I program a Paging Event from the front panel?.....	32

c.	How do I protect the 9000M2 from tampering?.....	35
d.	What to do if I've forgotten my security password?.....	35
e.	How do I update the firmware on the 9000 unit?.....	35
f.	How can I generate a configuration chart to distribute to field techs?.....	36
<b>7.</b>	<b>Controlling the 9000 Series</b>	
a.	How do I control the 9000 Series from the front panel? .....	37
b.	How do I control the 9000 Series using Remote Volume inputs? .....	37
c.	How do I connect the ZM Serial Remotes?.....	39
d.	How do I set the ZM Remotes to control channel volume?.....	40
e.	How do I set the ZM Remotes to change Scene Memory?.....	40
f.	How do I set up a ZM Remote to select Program Sources?.....	41
g.	How do I set the ZM Remotes to Initiate Paging?.....	42
h.	How do I set up a ZM Remote to activate Control Outputs?.....	42
i.	Can the ZM buttons select the source controlled by the volume knob?....	42
j.	How do I control the 9000M2 Series using Serial Control?.....	43
k.	How do I control the 9000M2 Series using Contact Closures?.....	43
1	Control In Settings Page.....	43
2	Control Out Settings Page.....	44
l.	How can I check the contact closure functions without switches?.....	45
<b>8.</b>	<b>Paging with the ZP-001T</b>	
a.	How do I perform paging using the ZP-001T ?.....	46
b.	How do I determine when to use Paging Port or Ring Signal Mode?.....	48
c.	How do I accomplish Zone Paging if I only have one output?.....	49
<b>9.</b>	<b>Ambient Noise Control with the AN-001T</b>	
a.	How does the AN-001T work to compensate for ambient noise?.....	50
b.	What settings should I use for the AN-001T?.....	51
<b>10.</b>	<b>Miscellaneous</b>	
a.	How do I trouble shoot the 9000 Series?.....	53
b.	What Happens If I unplug the power cord or power is lost?.....	54
c.	What do the error messages mean?.....	54
d.	Block Diagram.....	55
e.	Signal Flow Diagram.....	55
f.	NOM Table.....	56
g.	Where can I find additional 9000M2 Series Support Resources?.....	57
<b>11.</b>	<b>Glossary of Terms</b> .....	58

# What's changed?

## ***What are the differences between the original 9000 and the 9000M2?***

Fundamentally, the hardware remains the same. Except for the new orange logo on the front panel, the two units look virtually identical. However, we've made some less visible, yet dramatic improvements inside.

First, the independent operating modes (Mixer/Matrix) in the original 9000 Series are gone (as is the mode switch on the back panel). The functions of these two modes are now combined in a single, streamlined operating system. It is now possible for the 9000M2 to perform mixing/scene-based tasks and priority paging functions simultaneously. The BGM distribution functions have now been assigned to the new remote controls, since these functions will mostly be accessed by wall-panel controllers.

Second, the GUI software has been refined for easier, more user-friendly navigation. There are setup wizard functions to take you through the process of hardware selection, remote assignments, etc... and no more "pages on top of pages" view. Everything is visible all the time, in a multi-window environment. The PC connection speed has also been dramatically sped up for faster upload and download of setup data. Even the firmware update tools are built into the GUI software. Other small tweaks have been added to make the GUI interface easier to work with.

Lastly, the compliment of remote controllers has been expanded to accommodate virtually any situation. The 9000M2 can now take full advantage of its multi-zone ability with the use of up to 16 assignable remote controllers (one for every input and output). These will provide the same non-disruptive control of source broadcasting as Matrix mode, but in a much more flexible and efficient manner. These will now make it possible to effectively design multi-zone & room-combining systems.

**ⓘ Note: Programming files (.mtx or .mix) from the 9000 will not work with the 9000M2, nor can the files from the 9000M2 work with the original 9000. They are different operating systems and there are many changes. Also, the 9000 cannot be upgraded to a 9000M2. However, the original I/O modules and remotes are still usable with the 9000M2.**

	<b>9000 Series</b>	<b>9000M2 Series</b>
Number of Presets	32 Scenes or 32 events	32 Scenes + 32 events
Number of Modes	Mixer / Matrix	Mixer
Paging Priorities	<b>8</b> (7 + BGM)	<b>4</b> (3 + BGM)
Max # of Remote Controllers	4 (using main frame + C-001T)	20 (using mainframe, C-001T & RC-001T)
Displays speaker EQ	No	Yes
ZP-001T Modes	One	Three
Programming	Standard GUI	Enhanced Multi-view GUI
Usable Remote Types	<b>3:</b> ZM-9001, ZM09002, ZM-9003	<b>7:</b> ZM-9001, ZM09002, ZM-9003, ZM-9011, ZM-9012, ZM-9013, ZM-9014

# 1. Hardware Configuration

Out of the Box:

## a. What Comes Supplied With My 9000M2 Series Unit?

Generally, ALL 9000M2 Series mixers are packaged with the following accessories:

- IEC Power cord
- 14-conductor removable control block connector (for Volume 1-2 & control In/Out 1-4)...
- Rack-mount ears (Yey!)
- Blank panels for all module slots **except** for module slot #1.
- CD-ROM containing operations manuals (pdf) plus GUI programming software.
- 5 Year US Warranty
- There are additional phoenix connectors provided as well. However, these may vary slightly by model:

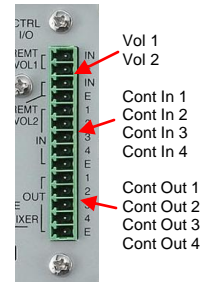

- **M9000M2:** (2) 3-conductor Phoenix connectors (for Channels 1 & 2 balanced line outputs).....



- **A-9060DHM2, 9120DHM2:** (1) 4-conductor phoenix connector (for Channels 1 & 2 speaker outputs) Pre-Out/Amp In (RCA).....

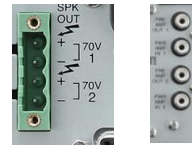

- **A-9060SM2, 9120SM2:** (1) 3-conductor Phoenix connector (Channel 2 line output).....  
(1) 7-conductor phoenix connector (Channel 1 Speaker output), (1) Pre-Out/Amp-In (RCA).....

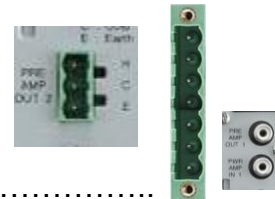

***\*If your speakers are connected to the 70V, 25V or 8 ohm terminal, be sure the supplied jumper wire is connected to the 4 ohm direct and trans-in terminals.***

- **A-9240SHM2:** (1) 3-conductor Phoenix connector (Channel 2 line output).....  
(1) 4-conductor phoenix connector (Channel 1 Speaker output), (1) Pre-Out/Amp In (RCA).....

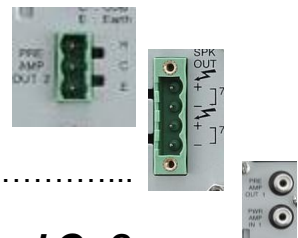

## b. What State is the 9000M2 Series in when it is first Powered On?

- Currently, the 9000M2 Series in all its forms comes out of the box with **all** inputs set to (-) priority (basically, no priority-all sources mixed) feeding **all** outputs (how many depending on which modules are installed). This enables you to test the audio through-put (all sources and all zones) without the need for programming. Once audio has been verified, you can proceed to program the unit for your particular needs.

### c. What function does each module perform?



#### D-001T Dual Mic/Line Input Module with DSP

1. Two Balanced Mic / Line Inputs
2. Digital Signal Processing: 10-Band Parametric EQ, Bass / Treble, Loudness, High and Low Pass Filters, Compressor, Adjustable Sensitivity (mic/line) Phantom Power (24 VDC)
3. Removable Terminal Block
  - Required for VOX (Voice-Operated Switch) function and input signal level metering



#### D-001R Dual Line Input Module with DSP

4. Two Unbalanced Line Inputs
5. Digital Signal Processing: 10-Band Parametric EQ, Bass / Treble, Loudness, High and Low Pass Filters, Compressor, Adjustable Sensitivity
6. Dual summing RCA connectors
  - Required for VOX (Voice-Operated Switch) function and input signal level metering

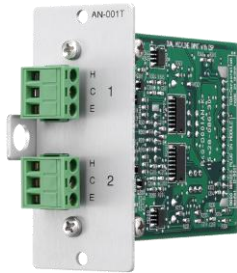

#### AN-001T Ambient Noise Control Module

- Automatically adjusts output gain to compensate for changes in ambient noise level
- Each input can be assigned to control a specific output
- Two inputs with +24VDC phantom power for condenser mics
- 14 preset gain ratios
- Accessory sensing microphone available, model AN-9001



#### ZP-001T Telephone Paging Module

- Telephone Access Paging to up to eight zones
- Uses DTMF dialing to access amplifier and/or line outputs
- Dial up to eight output zones in one operation
- Analog Extension or Page Port compatible
- Page port operation requires contact closure activation and DTMF signal pass-through
- RJ-11 Telephone Jack and Removable Terminal Blocks

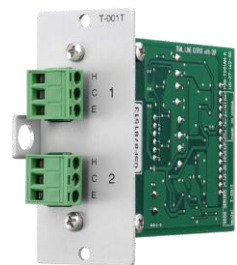

#### T-001T Dual Line Output Module

1. Two Balanced Line Outputs
2. Digital Signal Processing: 10-Band Parametric EQ, Bass / Treble, Loudness, High and Low Pass Filters, Compressor, TOA speaker EQ presets, Delay
3. Removable Terminal Block
4. Output signal metering



## C-001T Input / Output Control Module

- Eight assignable control inputs for activating Event/Scene, Volume Up/Down (Input or Output), Mute (Input or Output), Power On/Off, Emergency Mute or Synch On/Off
- Eight assignable control outputs for activating external devices
- Adds control Inputs/Outputs #5 through #12
- Removable Terminal Block

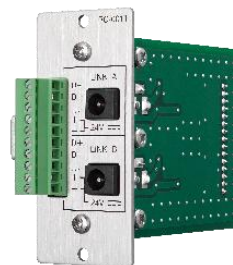

## RC-001T Serial Remote Control Module

- Allows use of up to 16 RS-485 remote control panels
- Bi-directional RS-485 communication provides control and status feedback display for each remote function
- Dual ports allows independent home runs for up to 8 modules each
- 24 VDC power adapter (optional AD-246) required for each port used
- May be used in any control option slot on 9000M2 frame and even in addition to a C-001T when spare slots are available

## 900 Series Modules

- NOTE:
- Various Input, Output and special function modules designed for the BG, 700 & 900 Series will also work with the 9000M2 Series. However, the operation of many of these modules may be limited as follows:
- **Input & Output** modules do NOT provide the DSP features, VOX, metering capability and are not in a two-channel configuration like the 9000M2 modules. They will provide audio and those that have local remote and/or mute-send/receive functions will operate in that way. Except for volume, no settings from these modules can be programmed using the 9000M2's software or front panel controls.
- **Special function modules**, such as tone generators, message repeaters, etc..., will output audio to the mixer and will have level adjustment and may be routed to any desired outputs. \*Please refer to the 900 Series Module Guide for more details.



## Other Accessories:

### AN-9001 Ambient Noise-Sensing Microphone



- Up to 2 may be used with each AN-001T module
- Omni-directional condenser type mic element
- 24VDC phantom power operation (provided by AN-001T)
- Single-gang box for easy mounting
- Removable 3-wire phoenix connector
- Low-profile, easily removable cover plate
- Each of up to (4) AN-9001s may be assigned to sense/control a separate zone or several may be assigned to control a single zone.



## d. Which Modules Go Where?

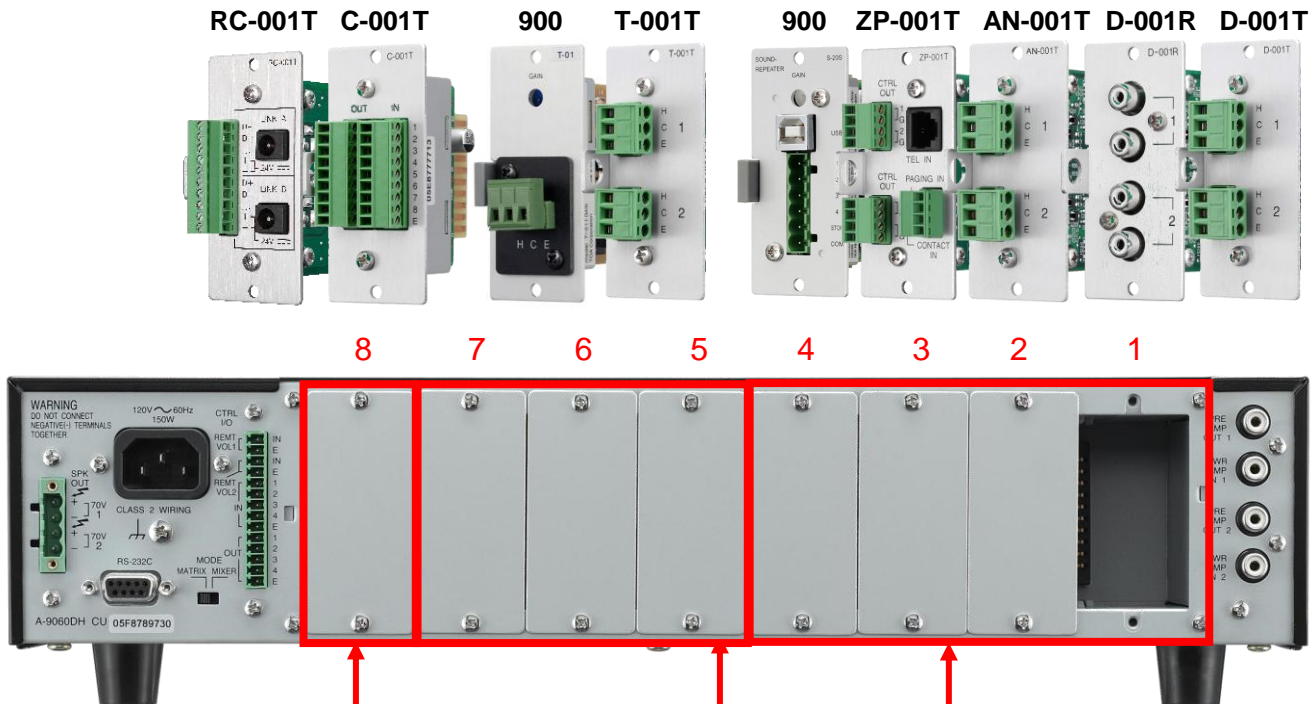

### First open Slot after ALL others:

1. RC-001T
2. C-001T
  1. Max of **1** each
  2. Both may be used if two slots are available

### Slots 5-7:

3. T-001T (ALWAYS starting from Slot # 5)
  1. Max of **3**
4. 900 Series (After 9000M2 Series)
  1. Up to **4** 900 modules

### Slots 1-4:

- D-001T : Max of **4**
- D-001R: Max of **4**
- AN-001T: Max of **2**
- ZP-001T (after D / R / AN): Max of **1**
- 900 Series (after 9000M2 Series)
  - Up to **4** 900 Series modules **i**
- Either D or AN modules may be ordered in any way starting from Slot 1-up to four total

**i** Up to (4) S-20S message repeater modules may be loaded into current versions of the 9000M2 Series.

AN-001T, ZP-001T & 900 Modules each take one slot, replacing two Mic/Line Inputs.

**[Example of audio 8 IN/8 OUT and control 12 IN/12 OUT configuration]**

8	7	6	5	4	3	2	1
C-001T Control 8 inputs 8 outputs	T-001T Audio 2 outputs	T-001T Audio 2 outputs	T-001T Audio 2 outputs	D-001T Audio 2 inputs	D-001T Audio 2 inputs	D-001T Audio 2 inputs	D-001T Audio 2 inputs

**[Example of audio 5 IN/4 OUT, control 4 IN/4 OUT, and ambient noise sensor 2 IN configuration]**

8	7	6	5	4	3	2	1
Open slot (Attach the blank panel)	Open slot (Attach the blank panel)	900 series module Audio 1 input	T-001T Audio 2 outputs	900 series module Audio 1 input	900 series module Audio 1 input	AN-001T Ambient noise sensor 2 inputs	D-001T Audio 2 inputs

**[Example of audio 2 IN/4 OUT, control 4 IN/4 OUT, and ambient noise sensor 2 IN configuration]**

8	7	6	5	4	3	2	1
Open slot (Attach the blank panel)	Open slot (Attach the blank panel)	RC-001T Remote Module	T-001T Audio 2 outputs	Open slot (Attach the blank panel)	900 series module Audio 1 input	ZP-001T Audio 1 input	AN-001T Ambient noise sensor 2 inputs

**ⓘ “D” modules should be grouped together and not alternated with “AN” modules. The best way to determine module slot configuration is to use the 9000M2 Series GUI Software on your PC. The software will not permit “illegal” module configurations. The hardware and software configurations must match.**

**900 Series Modules:** The following 900 Series modules are available and will work in **any** of the 9000M2 Series Module Slots (after 9000 modules). Please refer to the 900 Series Module Guide for more detail:

- **Input: Mic**- ML-11T, M-01S/F/M/P, M11S, M-41S, M-51S/F, M-61S/F, M-03P, M-21S
- **Input: Line** - ML-11T, B-01S/F, L-01S/F, U-01S/F, U-01P/R, U-03S/R, B11S, L-11S, U-11S/R, U-12S, U-13S/R, U-14R, B-21S, U-21S, B-41S, L-41S, U-43S/R, U61S
- **Line Output** - T-01S, T-02S, T-12S
- **Special** - S-01S, S-02S, S-04S, S-20S, V-01S (\*E Series equalizer modules are not required, since the 9000M2 Series outputs include the EQ presets for these speakers).

***e. How can I tell which modules are installed if the 9000M2 is racked?***

Enter the **UTILITY** menu and using the ▲/▼ arrows, locate the **MODULES** page. Then, press the ► arrow, the display will show SLOT # and module type. Use the **PARAMETER** knob to scroll through the SLOT positions to see which module is installed. If 900 Series modules are installed, these will simply display as “900”, but will not indicate which type.

**f. What DSP functions are available in each module?**

**Below is a block diagram of the Input / Output DSP Functions:**

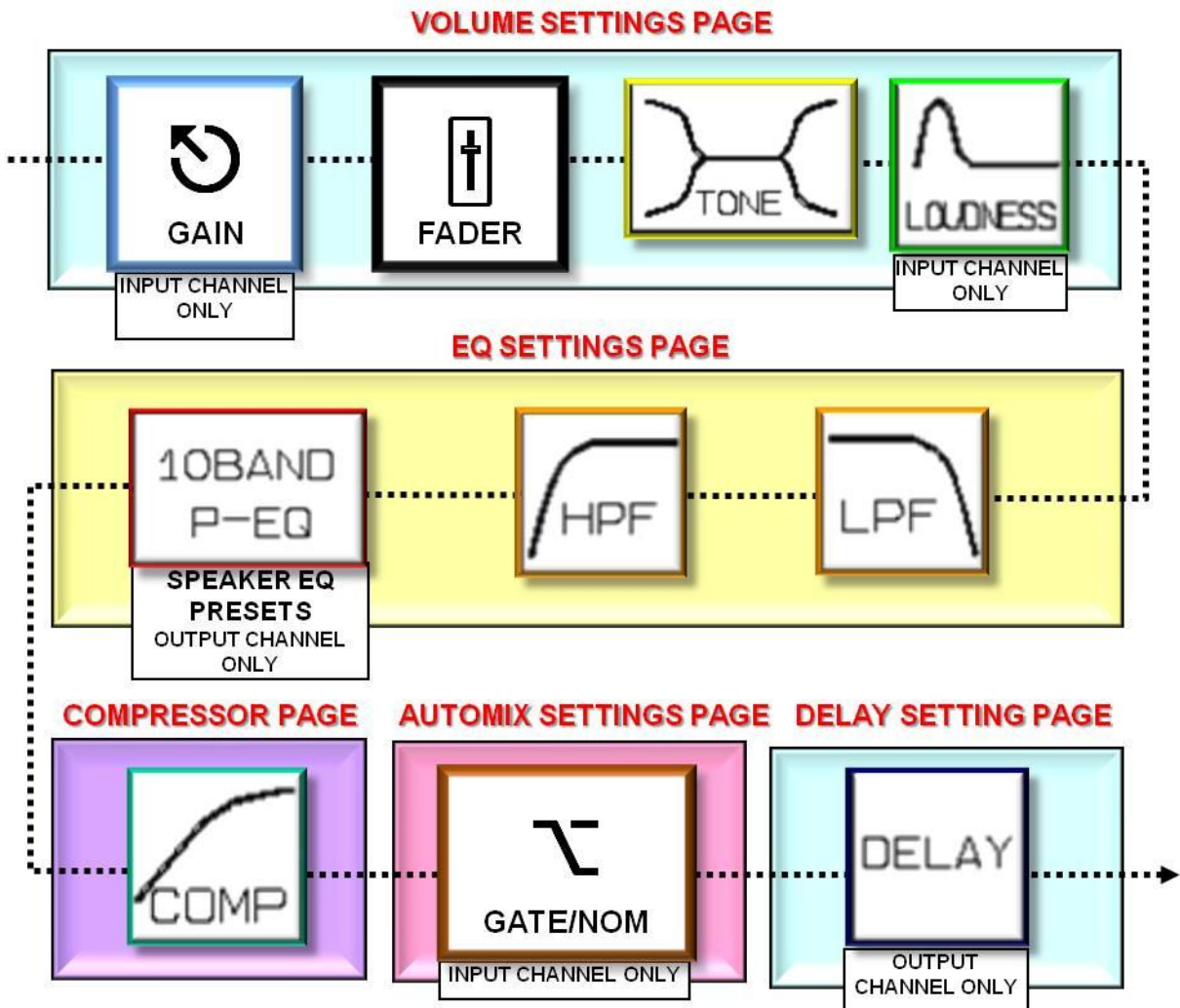

**ⓘ Input/Output Channel and Control DSP functions are contained within the module hardware itself and are not available unless these modules are installed in the 900M2 Series Frame: D-001T, D-001R, T-001T, C-001T.**

**The 900M2 Series Mainframe includes 2 channels of Output DSP.**

**The above DSP functions are NOT available for AN-001T, ZP-001T or 900 Series modules.**

**In addition, 900 Series modules do not offer any metering and occupy one slot per channel (as opposed to one slot per *two* channels with the 9000 Series modules).**

### ***g. When do I need to use this module?***

- **D-001T:** When connecting 1 or 2 balanced mic or line input sources. When initiating Paging using VOX function. Each channel can be set for Mic or Line independently.
- **D-001R:** When connecting 1 or 2 unbalanced line sources. Channel 1 or Channel 2 – 2 x RCA connectors provide stereo signal summing. Or use one RCA connector from Channel 1 and one RCA connector from Channel 2 for Stereo Input.
- **AN-001T:** When using 1 or 2 AN-9001 sensing mics for Ambient Noise Control
- **ZP-001T:** When interfacing with a telephone analog extension port (FXS) (Ring Signal Mode), to allow using a phone extension as a paging source or to a standard line level audio output of the telephone system which passes DTMF signals with a contact closure output (Paging Port Mode).  
–NOTE: If there is a standard line level audio output from telephone system which does not pass DTMF, or does not have the contact closure output, we would instead recommend using a D-001T module with the input set to VOX.
- **T-001T:** When connecting to 3 or more external amplifiers (the base 9000M2 unit has at least 2 outputs, either 2- line outs, 2- powered outputs or one of each).
- **C-001T:** When connecting to 5 or more contact-closure ins or outs (the base 9000M2 Series unit has a compliment of 4 contact closure ins & outs).
- **RC-001T:** When using any combination of ZM-9011, 9012, 9013 & 9014 remotes.
- **900 Series:** When a special function (i.e.-message repeater, tone generator) or only simple operation is required (input w/volume control). These also work in a pinch when a 9000M2 Series module is not available.

### ***h. What if I Need More Inputs/Outputs?***

- The input/output configuration on the 9000M2 Series may be expanded to a full complement of 8 Inputs (4 modules) x 8 Outputs (3 modules, plus built-in 1&2). If the application requires more than this, you have a few options:
  - a. Although 9000M2 units cannot be truly “cascaded”, the outputs of one may be “subbed” into the inputs of another unit. It’s also possible to set programming via contact in/out so that memory change and other functions may operate in sync.
  - b. Depending on the application, the inputs or outputs of multiple 9000M2s may be able to operate independently (negating the need for running in tandem). For example: when running independent paging or BGM sources to isolated zones. Beyond this, there may simply be a need for a larger mixer (check out the TOA D-901).

### ***i. What are the PRE OUT & AMP IN connections used for?***

These are used as a “loop” in/out and allow connection of external processing equipment (such as an equalizer, compressor or feedback suppressor). Of course, the good news is the 9000M2 Series is equipped with an ample amount of on-board processing. However, in the event you require some piece of outboard gear to patch in between the preamp and power amp sections, these loops (also referred to as “inserts”) are provided on the powered models. There are 2 channels of in/out loops on the dual powered versions-A-9060DHM2, A-9120DHM2 and a single loop in/out on the A-9060SM2, A-9120SM2 & A-9240SHM2. These patch-points are post-output volume / pre-metering.



## 2. Getting Around the Front Panel Controls

### a. What do these buttons and knobs do?



1. **Input Select 1-8:** Selects the input channel to be controlled from either INPUT VOLUME and ON/OFF controls or channel to be edited from the menu. These are also used to enter the 4-digit security password for accessing locked areas. Pressing these buttons twice will toggle between the INPUT Meter display and the Fader display.
2. **Input Volume:** Controls the volume of the selected input channel
3. **Input On/Off:** Turns the selected input channel ON or OFF
4. **Output On/Off:** Turns the selected output channel ON or OFF
5. **Output Select:** Selects the output channel to be controlled from either OUTPUT VOLUME and ON/OFF controls or the output channel to be edited from the menu. Pressing repeatedly toggles through the available output channels.
6. **Output Volume:** Controls the volume of the selected output channel
7. **Memory:** Selects the memory page to access memories to be recalled, saved or deleted.
8. **Enter:** Verifies the current write or recall mode, such as “INITIALIZE MEMORY”, “MEMORY RECALL”, “SAVE CHANGES”, “ETC...”
9. **Parameter:** Varies the value of the selected parameter
10. **Utility:** Accesses the UTILITY menu, which controls various global settings.
11. **Esc/Back:** Reverts back to the previous menu page or escape to normal mode.
12. **▲/▼/◀/▶:** Navigation controls for accessing menu pages, parameters and characters for naming.
13. **Power:** Turns power to the unit on or off. When power is “Off” and the unit is still plugged into a live power source, the unit is in “Standby”, from which it can perform various remote power on/off functions.

### b. What do the indications on the display mean?

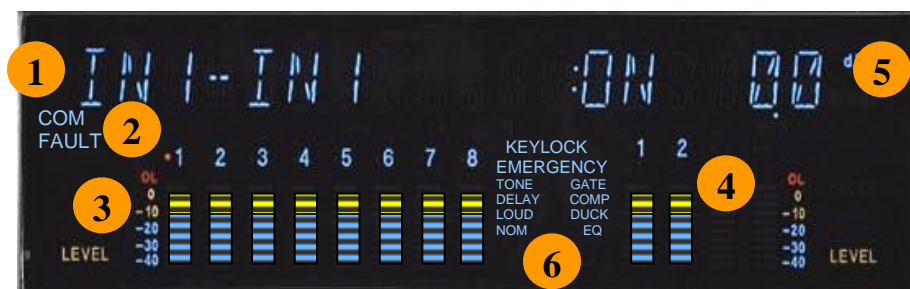

1. **Alpha-numeric Display (left side of “:”):** Indicates Channel/Presets/Parameter Name. The **COM** indicator remains lit during communications via the RS-232C

interface. The **FAULT** indicator lights when unit failure or other abnormal conditions have been detected.

2. **Channel Number Display.** Indicates either INPUT channel (left) or OUTPUT channel (right). These numbers will blink when channels are muted. A red indicator appears next to the channel which has been selected for editing.
3. **Input Level Meters:** Indicates the input signal level to each channel. Only channels which have corresponding 9000M2 Series modules installed will display levels. 900 Series modules and ZP-001T modules do not show input level. Pressing the channel button again switches the display to show fader level marks. Adjusting the input channel's level control will change the fader level, but not the input sensitivity. Only adjusting the source level or input sensitivity level will change the input level reading.
4. **Output Level Meters:** Indicates the signal level to each output channel. Pressing the "▼" arrow on the navigation controls (when not in the edit menu) switches the display to show fader level marks. Adjusting the output channel's level control will change the fader level. However, the level of input channels routed to that output will also affect the output's signal level reading.
5. **Alpha-numeric Display (right side of "·:·"):** Indicates the currently selected parameter's value or channel's status. A unit display to the right indicates units (dB, Hz, kHz, mSec) of the displayed value.
6. **Function Display.** Indicates which DSP effects are activated for the selected channels. Each one blinks when being edited.

*Note: The 9000M2 display now incorporates a "screen-saver" mode. If no adjustments are made using the front panel controls for 20 Minutes, the display times-out. It can be easily reactivated by pressing any button or turning any knob on the front panel. This helps to increase display life, which can often be shorted by remaining on for long periods of time when not being used.*

### **c. How do I edit settings from the front panel?**

- a. Working within the currently active memory preset (scene), when an input or output channel has been selected (and a red indicator ( • ) appears in the display next to the channel #), pressing the "▲/▼" arrows on the navigation controls enters the edit menu.
- b. You may then scroll through the parameters for that input or output channel (available parameters will vary depending on the type of module installed).
- c. Pressing the "▶" arrow highlights the parameter value portion of the menu.
- d. Adjusting the **Parameter Knob** changes the value of the selected parameter. Once a specific parameter has been selected, another channel may also be selected for adjustment of that same parameter (assuming similar module type).
- e. Pressing the "**ESC/BACK**" key reverts to the previous edit page or escapes the edit menu.
- f. Pressing the "MEMORY" button accesses the preset memory register.
- g. Here you have the option to **LOAD, SAVE, ERASE** or **POWER UP** a specific SCENE (POWER UP assigns that scene to load when the unit is powered on).
- h. Adjusting the **PARAMETER** knob selects the memory slot to be adjusted.
- i. Pressing "ENTER" stores/loads/erases the currently selected scene.
- j. Pressing the "**UTILITY**" button accesses the utility menu, where global or special functions may be edited. These settings are not stored with scene presets, but with configuration templates.
- k. The **UTILITY** menu is navigated the same way as the main edit menu and you may exit pressing the "**ESC/BACK**" button.

### 3. Operating Layers:

#### a. What is the difference between inputs assigned to the Scene and Paging Memories?

- Scene Memory:** This is the default for all non-priority Mic/Line Inputs. Best used for general mixing applications-i.e.-conference rooms, bar/restaurant, retail spaces, etc... Typically, this is for background music or live source mixing (such as microphones). The inputs assigned to the Scene will have a (-) next to the channel strip view in the main GUI software window. This indicates the input has not been assigned a priority and may not be used for paging. These inputs and their respective channel settings are stored within the scene. A scene change encompasses ALL mixed sources and settings for a given time. The mixer remains in that state until the environment requires a scene change. Also, inputs in this layer may be overridden (via Ducking) by higher priority inputs assigned to the Paging memory layer.
- Paging Memory** Paging allows the independent activation of individual paging memories or “events” which may be broadcast on a priority basis. As opposed to a global “scene” change memory, where everything changes at once, The Paging memories allow each input source to be activated independently from all the others, either by VOX or by remote control. Paging output levels and output assignments are set independently of the mixer input assignments and output levels and are not affected by scene changes. This is useful for multi-zone paging where mixer requirements change, but paging remain the same.

#### b. How does operation of these two layers differ?

Here are some examples of how each layer would operate (these are based on a full 8 x 8 configuration):

**Mixer:** Each **SCENE** memory contains all input/output settings and routing and can only be recalled one at a time. Also note that multiple inputs are routed to one or more output (as denoted by the color group).

##### Scene 1:

Output 1	Output 2	Output 3	Output 4	Output 5	Output 6	Output 7	Output 8
Input 1 BGM	Input 2 PAGE	Input 3 BGM	Input 4 BGM	Input 5 PAGE	Input 6 BGM	Input 7 MIC	Input 8 MIC

##### Scene 2:

Output 1	Output 2	Output 3	Output 4	Output 5	Output 6	Output 7	Output 8
Input 1 BGM	Input 2 PAGE	Input 3 BGM	Input 4 BGM	Input 5 PAGE	Input 6 BGM	Input 7 MIC	Input 8 MIC

**ⓘ All input/output settings such as Level, EQ, Compressor, Gate, Output Assignments, Delay etc... are stored with each scene. Therefore, each scene may have different channel settings as required.**





## 4. Programming from the GUI Software

### *How do I get started?*

#### **Installing the GUI software** ([software manual pg. 5](#))

First, insert the supplied software CD-ROM into your PC's CD-drive. Alternately, you may download the 9000M2 software from:

<http://www.toaelectronics.com/downloads/9000M2/GUI/Setup9000M2.zip>

Before you install the GUI software, your PC must have .NET Framework 3.5 SP1 installed. If it does not, the installer will prompt you to install it from the CD or the downloaded .zip file. Once NET software is installed, simply follow the 9000M2 installation wizard and the GUI software will properly install on your PC's hard-drive.

The installer will place a short-cut on your desktop. The installer will launch



Click this and the 9000M2 GUI

Programming and configuration of the 9000M2 Series is fast and intuitive using the GUI (Graphical User Interface) software. Using the GUI, a 9000M2 configuration template may be programmed entirely off-line, without a unit present and later, settings may be then uploaded to one or more units. Here we will outline the functions for each of the setting pages or “windows”.

**STEP 1: Start Menu.** When you first launch the GUI application, the setup start WIZARD window appears:

This window will ask you to do one of three things:

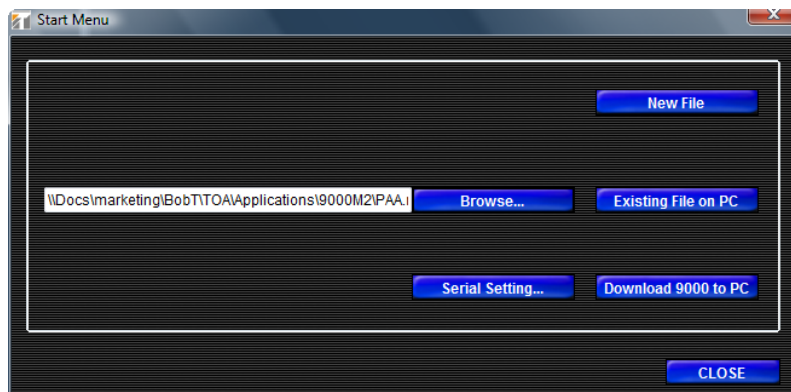

1. Begin programming a new configuration template from scratch [New File]
2. Load a previously stored template (.mx2) file from your desktop [Existing File on PC / Browse]. *Note: The “Existing File” tab searches the designated file folder, whereas “Browse” allows you to search anywhere on your PC.*

3. Download a configuration from a connected 9000M2 unit [Download 9000 to PC]

The “SERIAL SETTING” tab allows you configure and test your serial connection from PC to 9000M2 unit. It is important that you do this prior to attempting any upload/download of files, especially when doing firmware upgrades (more on this later).

**Step 2: Initial Setup Wizard-Module configuration Window.** This window will ask you to configure modules for the hardware slots on the rear panel of the 9000M2 unit.

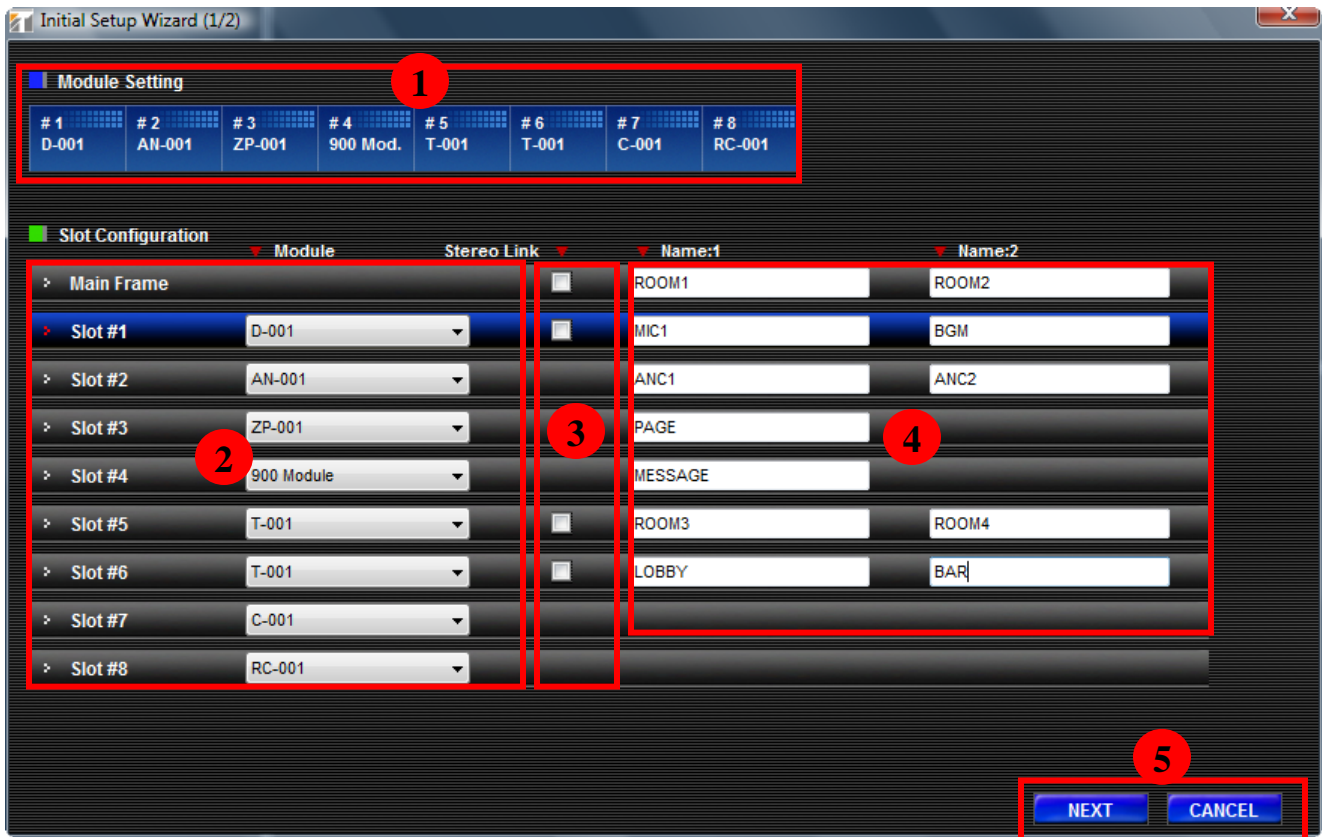

- 1. Module Setting:** Indicates which modules have been assigned to each slot. Indication changes as slot configuration is changed.
- 2. Slot Configuration:** The next step is to **assign the modules** to each slot. This must accurately correspond to the actual hardware that is loaded into the 9000M2 unit's frame. A mismatch may cause a malfunction and will certainly produce a configuration error, when uploading files to the unit. (\*see section 1 "Hardware Configuration").
- 3. Stereo Link:** This feature is applicable to inputs in the MIXER (non-priority) layer only. It allows linking of both inputs of each two-channel input or output module. Volume, EQ and other channel setting may be adjusted on one channel and the linked channel's settings automatically follow. This is useful for stereo zone applications (not available for AN-001T, ZP-001T or 900 Series modules).
- 4. Channel Label:** With each module populated, a **label "strip"** will appear on the right, corresponding to each module's input/output complement. You may enter a 7 character alphanumeric name for each input and output.
- 5. NEXT/CANCEL.** This button either takes you to the next page in the setup or cancels the process and reverts back to the initial startup window.

**STEP 3: Initial Setup Wizard-Remote Setup (2).** This page sets up the use of the remote volume port on the rear of the 9000M2 mainframe. These ports may be assigned to work with either the ZM-9001, ZM-9002 remotes or a standard volume potentiometer.

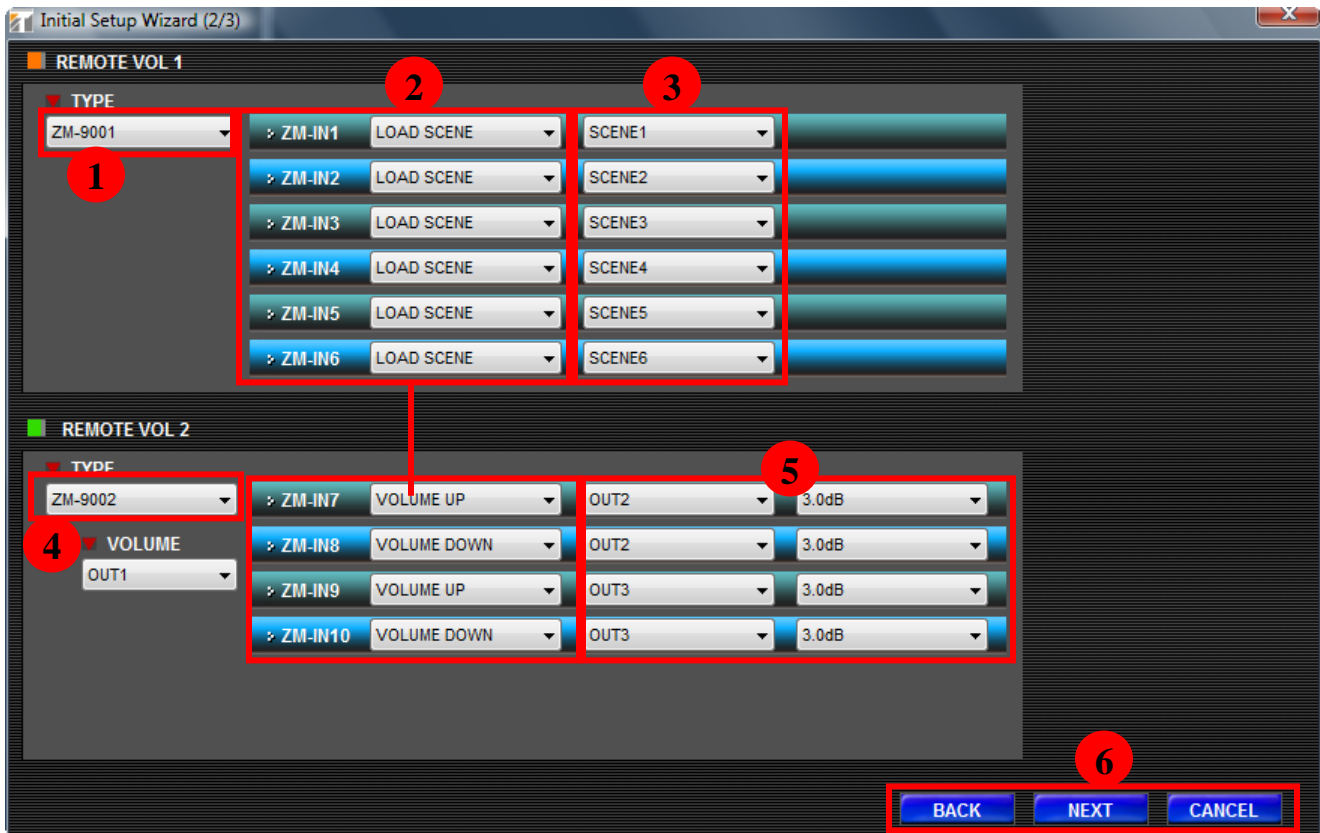

1. **TYPE.** Selects the controller type from the drop-down list (see “Controlling the 9000M2” for more details on the controllers):
  - **Volume**-When a 10kOhm variable resistance potentiometer is used for volume control.
  - **ZM-9001:** When a ZM-9001 Zone Manager is used
  - **ZM-9002:** When a ZM-9002 Zone Manager is used
2. If a ZM 9001 or 9002 is selected, this window allows selection of the following items to be controlled by the contact buttons:
  - **LOAD SCENE**- assigns the button to select one of the 32 preset memories (SCENE or EVENT\*\*)
  - **VOLUME UP**-Sets that button to control a volume up function
  - **VOLUME DOWN**- Sets that button to control a volume down function
3. If **LOAD SCENE** is selected in # 2, then this **selects one of the 32 preset Scene memories** to be loaded. **Note: These controls may not be used to activate Paging memories.**
4. If a **VOLUME** or **ZM-9002** controller is selected, then a box appears allowing selection of an input or output channel to be controlled.
5. If **Volume UP** or **DOWN** is selected for **ZM controller buttons in #2**, these set the **In/Out channel #** to be controlled, as well as the dB increment for each button press.
6. **Back/Next/Cancel:** Selects the next step in the setup process, goes back to the previous step or cancels the process.

## STEP 4: Initial Setup Wizard-Remote Setup (3).

This window sets up the use of the new serial (RS-485) remotes: ZM-9011, 9012, 9013 & 9014, used with the RC-001T Control Module.

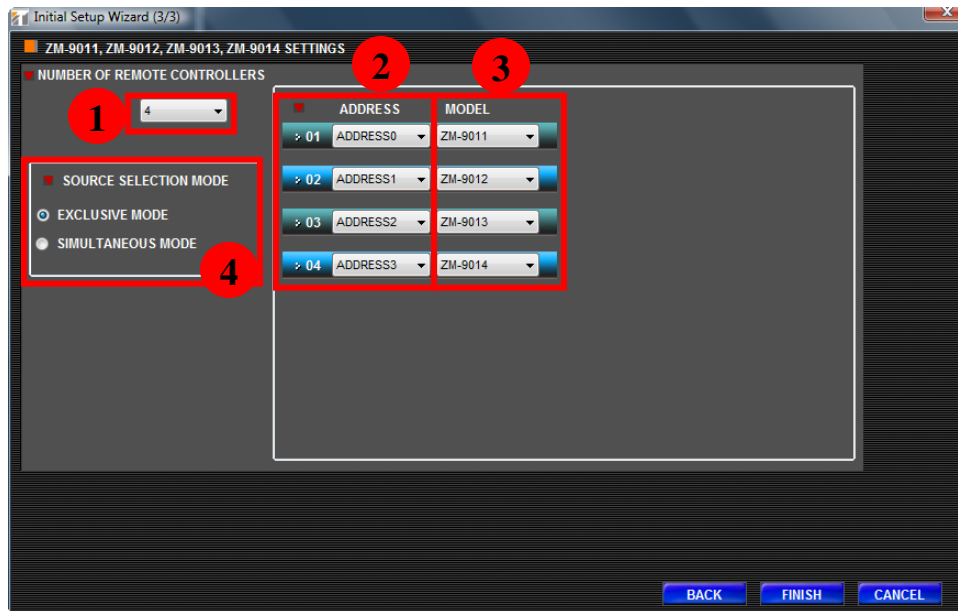

**1. Number of Remote Controllers** Selects the number of Serial ZM Remote Controllers (1-16). The page will populate according to the number selected.

**2. Remote Address:** Selects the corresponding physical address of each remote (set by a rotary pot on the side of each remote).

These settings must be in serial order and must match the physical settings on the remotes by connected order. Note: The address scheme in the GUI software is 0-15, while rotary pots on the remotes themselves are numbered 0-9, A-F (with A-F representing 11-16).

- 3. Remote Model:** Selects which of the four remote models is assigned to each of the positions: ZM-9011, ZM-9012, ZM-9013 or ZM-9014. These may be assigned in any combination.
- 4. Source Selection Mode:** This determines the behavior of the buttons when assigned to Cross-Point Change function.
  - Exclusive Mode:** Allows only one cross-point assignment per button. Each button pressed overrides the previously selected source to a given output. This mode should be used when priority selection of sources is required (i.e. -one source to an output at a time).
  - Simultaneous Mode:** allows each button to select one or more input sources to one or more outputs (non-priority inputs only). These may also be turned on or off independently. This mode should be used when a source must be assigned to more than one output or multiple sources must be assigned to a single output.
  - Note:** The mode selected above effects the behavior of **all** buttons assigned to cross-point change function. The mode assignment remains static throughout the configuration. It does not affect buttons assigned to scene change, paging initiate or control functions.
- 5. Back/Finish/Cancel:** Selects whether the process is completed, returns to the previous setup window or cancels the process.

If you've selected "FINISH", you are now done configuring the 9000M2 hardware. The GUI then generates the layout as you have elected. You are now ready to program how the unit will function.

You may return to the Remote Setting Wizard later to program the various individual remote functions.

## b. Main Configuration View

Once initial setup is complete, the Main Setting window will appear. This window allows access to all programming functions, through the main windows or drop-down menu.



- 1. Drop-down Menu:** Provide easy access short-cuts to all setup parameters and file management
- 2. Scene Memory View.** Displays the list of 32 SCENE memories, as well as the currently selected scene. All channel settings can be memorized to a SCENE preset for easy recall. Each scene may be named and also assigned to be a power-on default.
- 3. Main I/O Configuration View** This window provides an overview of the entire unit's Input / Output configuration. It will show all channel names, available DSP & signal routing. Clicking on any "block" will call up that parameter in the edit window below.
- 4. Active Edit View:** Displays the currently selected parameter. When editing a parameter in the main view window, that channel & the specific parameter will be highlighted in both windows.

***Input or output channel settings may be copied to other channels by right-clicking on the channel labels in this view. Bring the cursor to another channel and right-click to select PASTE. This copies all fader, EQ, compression and routing functions to that channel. This only works for channels with identical functions (i.e.-D-001T, T-001T).***

### c. Scene Memory View



1. Displays currently active scene
2. Selects Scene Bank (1-16, 17-32)
3. Displays Scene # (1-32)
4. Displays Scene Name (may being changed when recalled)
5. Selects Power On Scene
6. Selects Scene(s) to be deleted
7. Selects Last scene recalled on Power up
8. Load/Save/Delete commands

A **SCENE** is a memory preset containing all of the channel and routing settings associated with a given application. Select a Scene # (1-32) by clicking on it and when highlighted, you may perform the following functions:

- Enter a scene name (alphanumeric, 7 character)
- Assigning a particular scene to be the default scene each time the 9000M2 unit is powered on by clicking the circle to the right of the desired scene. The mixer may also be assigned to default to the LAST scene which was active before the unit was powered off.
- Deleting scenes which are checked off (under DEL) by pressing the DELETE button.
- Loading a scene from a .mx2 configuration template by selecting the scene # and pressing the LOAD button.
- Save the current mixer settings to a scene by selecting a scene #, then clicking on the SAVE button.
- **Scene Copy** (Not Shown) A scene may be copied into other scene presets by clicking on the scene to be copied to and pressing the SAVE button. The previously selected scene will save to the new location. This may be done repeatedly to as many scenes as necessary to copy redundant channel settings such as EQ & levels. The last scene that is copied to, automatically loads to become the active scene.

## d. Volume Setting View (D-001T/R, Mainframe Outs, T-001T)

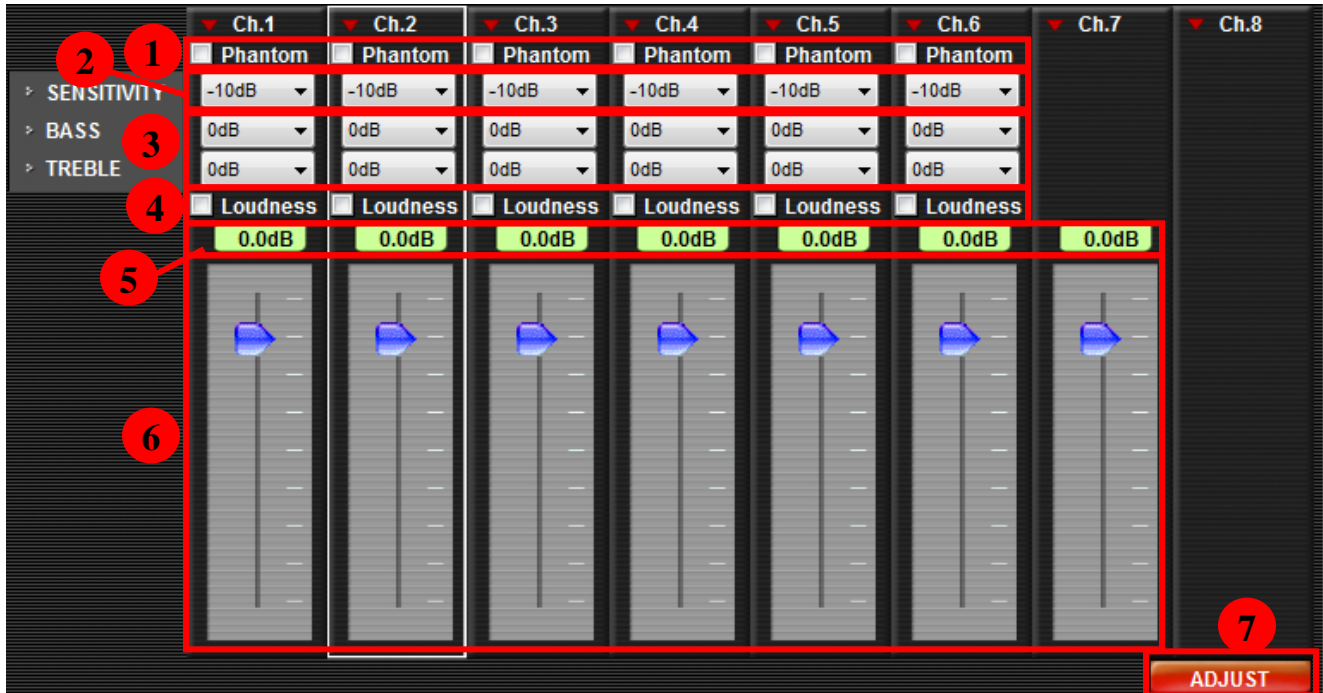

1. **Phantom Power** Checking this box turns 24VDC On/Off for individual Channels (D-001T Inputs only)
2. **Input Sensitivity** Adjusts each channel, from -10 (line level) to -60dB (mic level) (D-001T, D-001R Input only). Not available for other types of inputs. ⓘ
3. **Bass & Treble** Adjusts tone settings for each input (+/- 12dB) (D-001T, D-001R, Main Frame & T-001T outputs only)
4. **Loudness** Checking this box activates this function for each channel. This is useful for boosting background music played at lower volumes and affects mainly the bass range. (D-001T, D-001R, Main Frame & T-001T outputs only)
5. **Channel dB Reference Level:** Displays dB level according to fader setting (OFF, -70dB - +10dB) (D-001T, D-001R, Main Frame & T-001T outputs only)
6. **Faders.** These may slide up or down to adjust the desired fader setting. The dB reference level (#5) will change accordingly.
7. **ADJUST** function allows transmission of new settings to a serially connected 9000M2 unit. Making the assignment/level adjustment and clicking on this button is similar to making an adjustment on the front panel, but is being done remotely.

ⓘ **Please note: Many of these functions are present in both Input & Output fader pages. Some on Input page only. Volume Control ONLY is available for ZP-001T & 900 Series Input modules. Also, the AN-001T settings cannot be controlled from this window.**

**The volume settings will affect priority paging sources, so when programming scene changes, make certain these input settings remain the same for each scene. As mentioned previously, the paging output settings are independently adjust able so as not to be affected by zone output level changes**

## e. EQ Setting View (D-001T, D-001R, Mainframe Outs, T-001T)

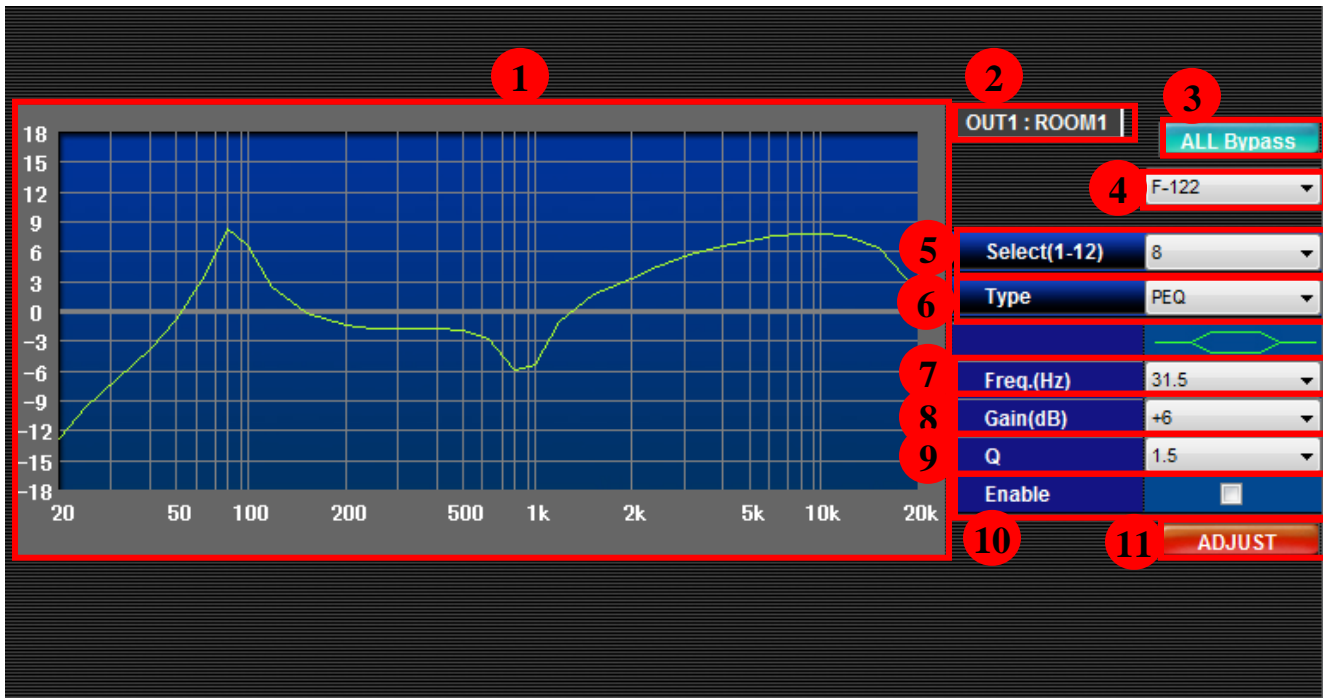

A 10-band parametric EQ, plus High-Pass Filter & Low-Pass Filters (12 filters total) are available for the following Inputs: (D-001T, D-001R, Mainframe, T-001T)

1. **EQ Curve Display.** Shows the overall curve and each EQ band's effect as it is adjusted.
2. **Active Channel Indication:** Indicates which channel is currently being edited.
3. **ALL BYPASS:** Activating this button returns EQ to its default setting (ALL Through). Allows all EQ bands to be turned ON/OFF simultaneously.
4. **Speaker EQ Presets (OUTPUT Channels only).** This selects one of the 30 EQ presets appropriate to the TOA speakers used. The presets use a number of the available EQ bands and displays the EQ curve applied\*.  
**Filter select (1-12):** Selects one of the 12 available filters to be adjusted.
5. **Filter Type.** Selects from: PEQ, HPF, LPF or Through (default). ***HPF & LPF may be used as Cross-over filters on the Output channels.***
6. **Frequency Adjust.** Selects the **peak** (PEQ-the frequency at which the filter exhibits the maximum cut or boost) or **corner** (HPF/LPF-the frequency at which the filter exhibits a 3dB drop in level) for each filter, depending on filter type.
7. **Gain.** Adjusts the amount of **Boost** or **Cut** for the selected frequency (+/- 12dB range)
8. **Q.** Varies the bandwidth and slope of the filter. This can be used to focus on a specific range (such as minimizing noise or hum at a particular frequency) or widened to affect a broader range (such as adding presence to the vocal range).
9. **Filter Enable.** Checking this box activates the filter as part of the overall EQ set. If unchecked, the filter has no affect on the EQ curve. May be used as a filter "bypass" to compare effects on sound when IN or OUT.
10. **ADJUST:** Allows transmission of new settings to a serially connected 9000M2 unit.

*\*Speaker EQ presets may only be applied using the GUI software and then uploaded to the 9000M2 unit.*

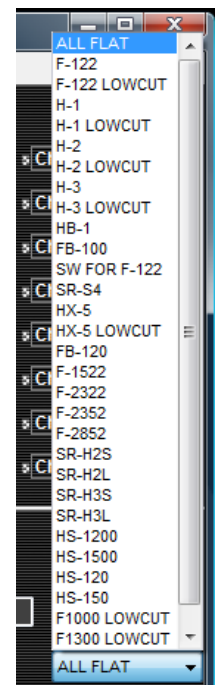



## f. Compressor View (Only in D-001T, D-001R, Mainframe, T-001T)

Used when excessive or inconsistent levels are present. Clicking on the COMPRESSOR box of any Input or Output channel will display all available compressors in the edit window below. Setting Range: OFF (default), 1, 2, 3, 4, 5).

- **1 Peak Limiter 1** (speech applications)

This protects amplifiers and speakers against damage caused by an excessive signal input.

- **2 Peak Limiter 2** (musical applications)

This protects amplifiers and speakers against damage caused by an excessive signal input.

- **3 Sonic Normalizer** (BGM reproduction)

This setting equalizes the volume of Background Music by boosting quieter sounds and lowering louder sounds, making overall volume more uniform.

- **4 Leveler 1** (Speech applications) Makes paging calls easier to hear by equalizing the difference in speech signal volume that may result from individual differences in speaker

voice volumes or variations in speaker-to-microphone distances. ⓘ

- **5 Leveler 2** Similar characteristics to Setting #4, but is a more dramatic setting.

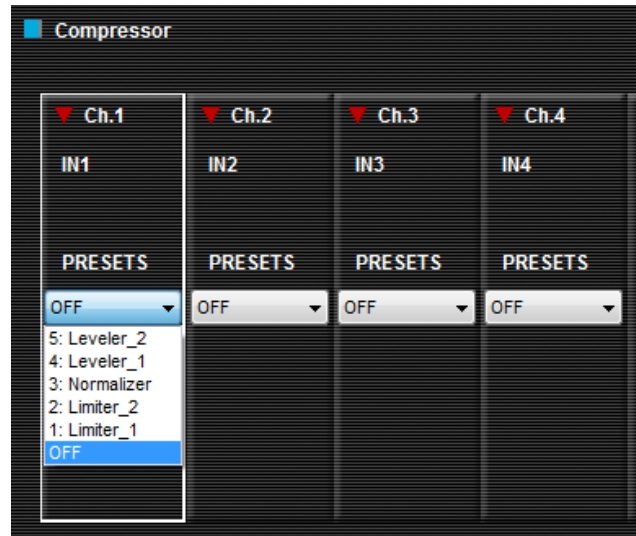

**ⓘ This setting may make the mic more susceptible to feedback. Special care must be taken when installing microphones and speakers.**

Compressor Preset Settings	Attack (Sec.)	Release (Sec.)	Offset1 (@Min IN, dB)	Ratio1 (Lower than T1, OUT/IN)	T1 (Threshold Level, dB)	Ratio2 (Btwn T1&T2, OUT/IN)	T2 (Threshold Level, dB)	Ratio3 (Higher than T2, OUT/IN)	Offset 2 (@Max IN dB)
1 (Peak limiter for Speech)	0.0001	0.1	10.5	1	-20	0.5	-10	0.05	-5.5
2 (Peak limiter for Music)	0.0001	1	10.5	1	-20	0.5	-10	0.05	-5.5
3 (Sonic normalizer for BGM)	0.0001	5	17	1	-30	0.8	-25	0.2	-16
4 (Speech leveler)	0.0001	0.1	18	2	-70	0.8	-38	0.125	-8.4
5 (Speech leveler)	0.0001	0.1	24.1	2.6	-70	0.4	-38	0.05	-4.7

COMPRESSOR

Graph of Compressor Curves

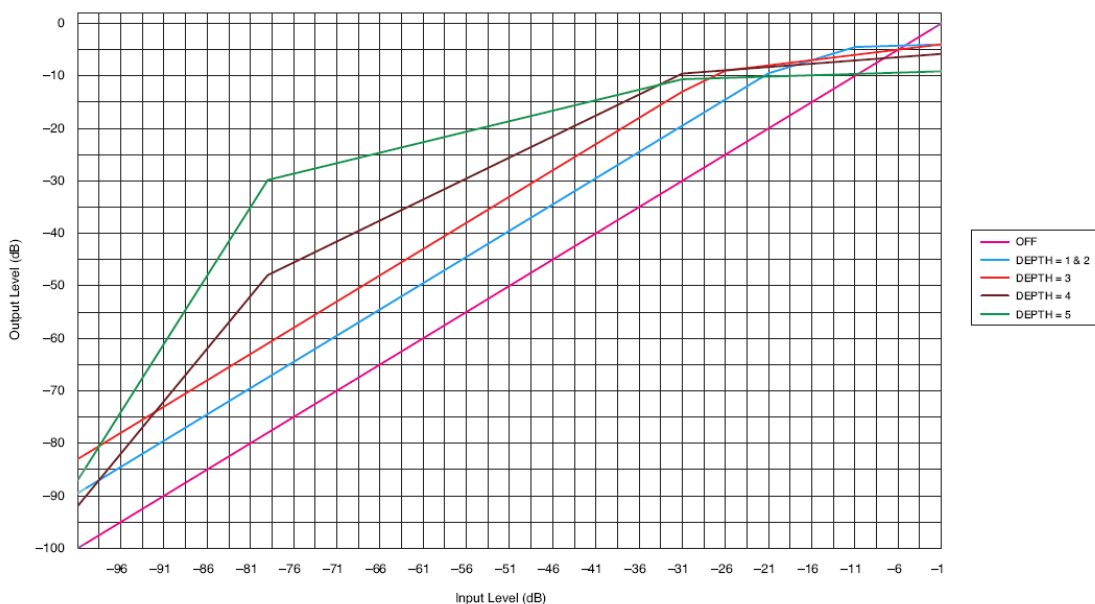

## g. Gate/NOM View (Only in D-001T, D-001R)

### How do I program the 9000M2 for Auto-Mixing?

The 9000M2 Series Auto Mixing function is simple, but very effective. This is used for conference rooms, court rooms and other live venues and is designed to minimize two problems associated with multiple microphone applications:

1. Sensitivity to feedback, due to increased system gain as microphones become active
2. Cross-talk from mic-to-mic, which can also not only increase feedback, but decreases intelligibility.

The Auto Mixing function helps to overcome these problems by employing two stages of mixing control:

1. **Gating:** This keeps crosstalk to a minimum by turning off microphones that are not used at a given time. When a speaker begins speaking into the microphone (above the threshold level), the gate opens to allow audio to pass through. When the speaking stops, the gate closes again to maintain a quieter background. **This function is available on the D-001T & D-001R only.**
2. **NOM (Number of Open Microphones).** This process works on the principal that, for every time the number of live or “open” microphones is doubled, the overall volume increases by 6dB. Therefore, we would need to reduce the system’s level by 6dB in order to maintain a consistent volume and prevent feedback. The NOM calculation is a logarithmic function represented as:  $x\log\text{NOM}$  (with  $x$  being the attenuation factor). A value of  $10\log\text{NOM}$  will reduce the system level by 3dB for every doubling of open mics. A value of  $20\log\text{NOM}$  will reduce the level by 6dB. Then, if we go from 4 live microphones to 8, a setting of 20 would automatically reduce the system by 6dB-maintaining the correct level.

We will find these settings in the **GATE/NOM Configuration edit window:**

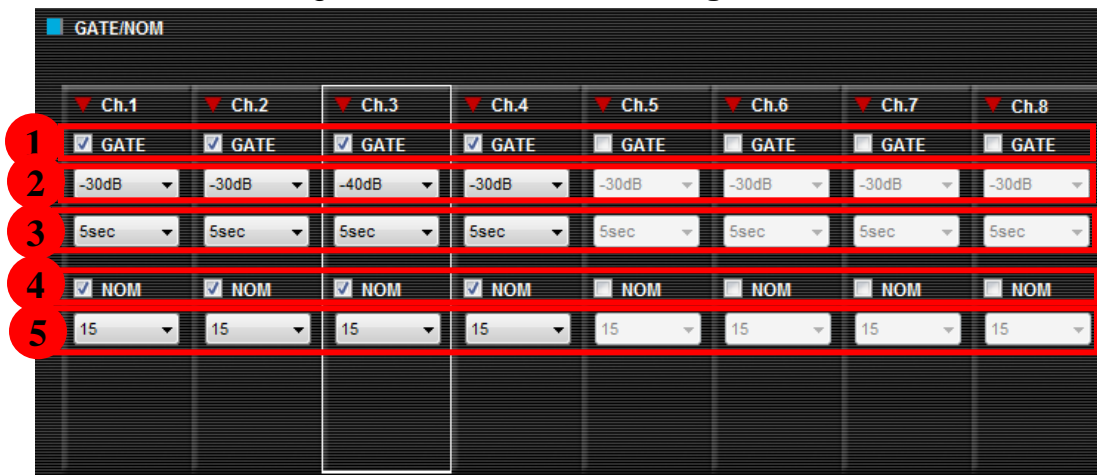

1. **GATE:** Checking this box activates the Gate function for each microphone.
2. **GATE THRESHOLD:** Sets the level which the input must exceed in order to “open” the Gate (-5 to -40dB range). Can be set independently for each microphone.
3. **GATE RELEASE TIME:** The time it takes for the Gate to close again once input signal has dropped below the threshold. This setting is the same for all microphones.
4. **NOM-** Activates the NOM attenuation functions for the selected mics.
5. **NOM ATTENUATION:** Sets the attenuation rate for the NOM function (1-20). A setting changed for one microphone affects all mics for which NOM has been activated. A setting of 20 provides the maximum attenuation, with 1 being the minimum. (\*See NOM Table in the **Chapter 13- Misc.**). This is the same setting for all microphones

**Ⓢ The Gate function may only be turned On/Off using the GUI software. If ON, the threshold is adjustable from the front panel, but it may not be turned On or Off.**  
**\*Gate must ON for Paging sources using VOX trigger function.**

## h. Output Assignment Setting View (Non-priority Inputs)



Clicking on the X-Point Matrix Block in the Main View will call up the Output Assignment View (also referred to as Cross-Point or X-Point view). This window allows assignment of each input channel to any or all available outputs (Cross-point). Only non-priority (-) Input channels may be assigned in this window. Output assignments for these Inputs are stored within the Scene memory.

a. Each box in the assignment matrix has a three-position check box:

a.  is OFF (no assignment)

b.  Clicking once assigns the channel to that output.

c.  The next click turns the box to RED and activates the cross-point fader on the right side of the display. This adjusts the selected input channel's contribution to that output channel.

b. **Cross-point Fader level:** Adjusts that channel's cross-point value (level contribution) to the assigned output.

c. **Priority Inputs:** Cross-point settings for inputs which are assigned a Paging Priority (1-3) will **not** be displayed in this matrix and are not stored within the Scene memory.

d. **ADJUST:** Allows transmission of new settings to a serially connected 9000M2 unit. Making the assignment/level adjustment and clicking on this button is similar to making an adjustment on the front panel, but is being done remotely.

## i. Delay Setting View (Mainframe Outs, T-001T)

Clicking any **DELAY** block in the OUTPUT settings section of the Main view, will call up the Delay Edit window.

Each Output channel may be set for a maximum of 40mSec of delay. However, since the Output channels are paired, this delay is the total ms per pair. Therefore if one channel of the pair is set for 40mSec, the other channel will be 0mSec. If one channel is set for 20mSec, the other can also be set for 20mSec, etc.. (see below example). This function may used to compensate for “slap” echo in larger rooms being fed by multiple outputs.

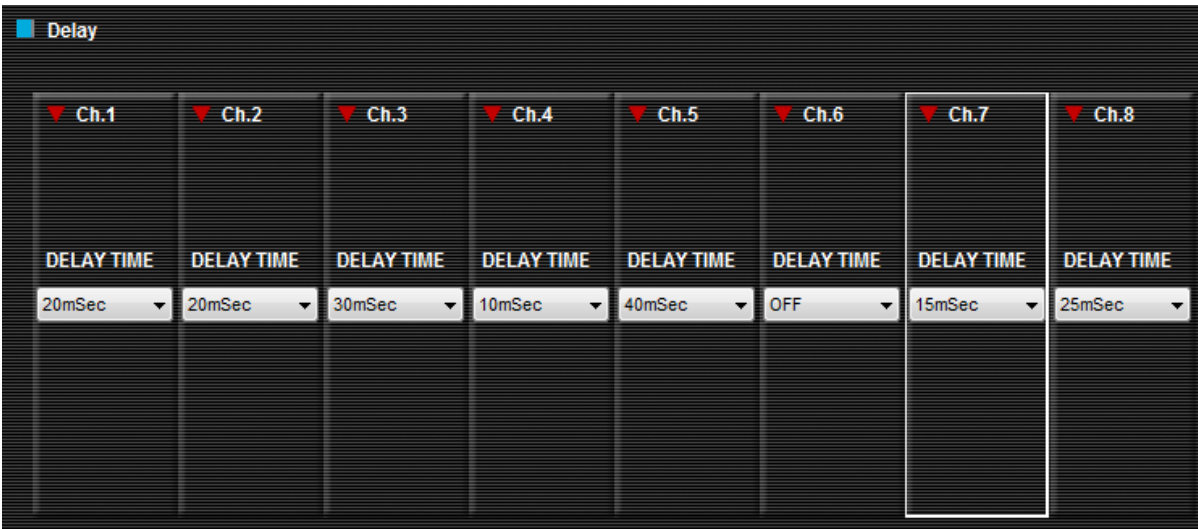

The screenshot shows a 'Delay' configuration window with eight channels. Each channel has a 'DELAY TIME' label and a dropdown menu. Channel 7 is highlighted with a white border.

Ch.1	Ch.2	Ch.3	Ch.4	Ch.5	Ch.6	Ch.7	Ch.8
20mSec	20mSec	30mSec	10mSec	40mSec	OFF	15mSec	25mSec

## e. Paging Settings : How do I set the 9000M2 for priority paging?

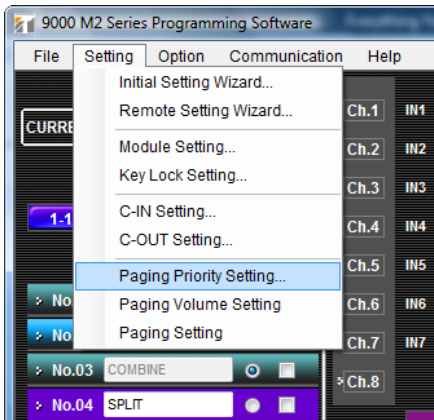

### a. Input Paging Priority Setting:

These settings may be found in the drop-down Menu under Paging Priority Setting. It is first important to assign a **priority level** (1-3) to a source you would like to use for paging. This can be a mic, message playback unit, or ZP module (telephone page).

Once the priority level is set, the **ducking level** (the amount of the level by which that source will be reduced when a signal of higher priority is activated), must also be set. The adjustable ducking range is between 0dB (no change in level) to OFF (sound mutes completely during a priority broadcast). The adjustments in-between will simply reduce the level of that source by the selected amount.

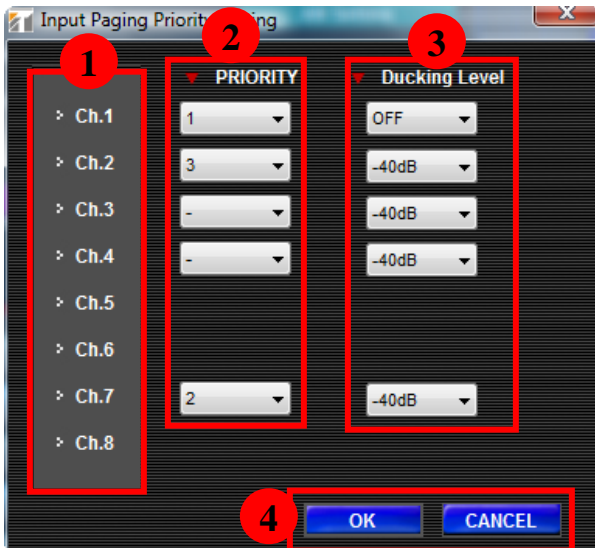

1. Displays the priority Input **Channel #**
2. Selects **Priority Level** (1, 2, 3, -)
3. Selects **Ducking Level** (OFF, -50, -40, -30, 20, -10, 0dB)
4. **Verifies** Settings (OK) or Cancels process.

This example illustrates the effect each priority will have on the lower priority signals.

Higher priority signals will Duck ALL lower priority signals according to the set Ducking Level..

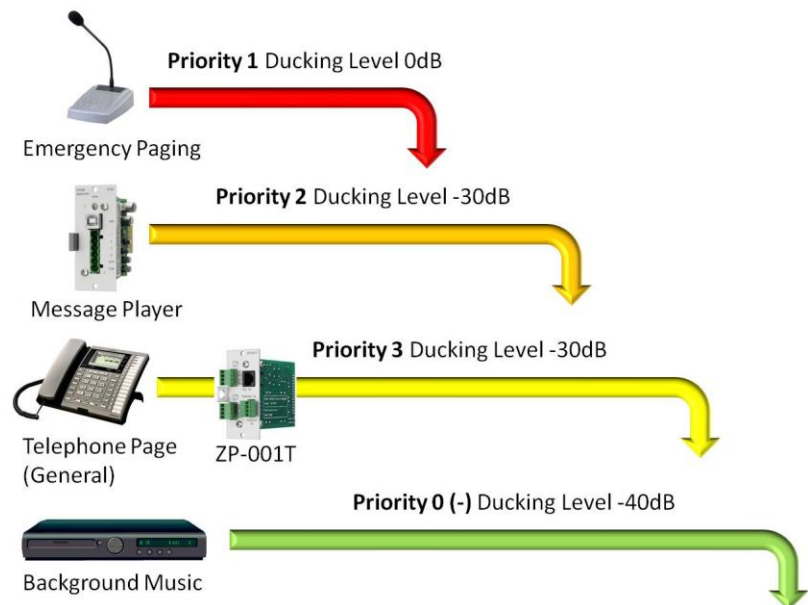

## b. Paging Volume Setting

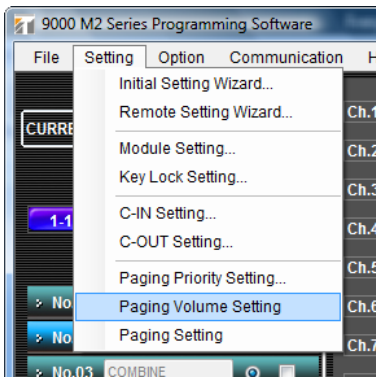

These settings may be found in the drop-down Menu under **Paging Volume Setting**. Here an Output Volume adjustment may be set that is independent of the “normal” Output Volume setting. Whether the Output volume is changed due to a scene change or a manual adjustment (i.e.-by remote), the paging signal will always be output at the pre-adjusted level. This avoids situations where during down (or muting) the output (zone) volume for background music, inadvertently also turns down the paging level. This assures that the page output remains unaffected.



- 1. Channel dB Reference Level:** Displays dB level according to fader setting (OFF, -70dB - +10dB) (D-001T, D-001R, Main Frame & T-001T outputs only)
- 2. Faders.** These may slide up or down to adjust the desired fader setting. The dB reference level (#5) will change accordingly.
- 3. ADJUST** function allows transmission of new settings to a serially connected 9000M2 unit. Making the assignment/level adjustment and clicking on this button is similar to making an adjustment on the front panel, but is being done remotely.
- 4. This setting may be accessed on the front panel in the OUTPUT Settings menu.**

This example illustrates the Paging Volume function. Regardless of where the output level is set (by way of scene recall or manual adjustment), the Page is broadcast at the pre-assigned level

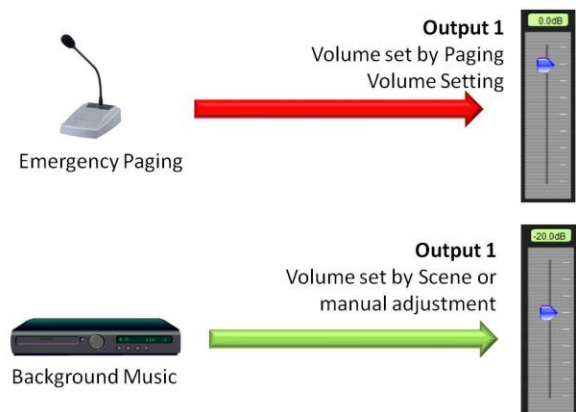

**Note: Bass, Treble & Loudness are not adjustable in the Paging Volume window. The settings for the main (scene-based) output channel will be in effect.**

## c. Paging Settings

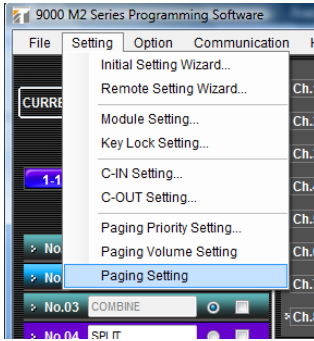

These settings may be found in the Drop-down Menu under **Paging Setting** or by clicking on the **PAGING** button in the Main Window. Here the priority input sources, trigger functions and output assignments may be selected. Each source selected occupies a Paging Preset. There are 32 Paging presets. All of these are stored as part of the configuration (.mx2) file and are independent of the scene memories.



Paging Preset #	INPUT	PRIORITY	TRIGGER	OUTPUT Ch.								SYNC OUT	
				1	2	3	4	5	6	7	8		
No.1	IN1	1	RM2SW1	x									OFF
No.2	IN1	1	RM2SW2		x								OFF
No.3	IN1	1	RM2SW3			x							OFF
No.4	IN1	1	RM2SW4	x	x	x							OFF
No.5	IN2	3	RM2SW5	x	x	x							OFF
No.6	IN2	3	RM2SW6				x	x	x				OFF
No.7	IN7	2	ZP(AUTO)	x	x	x	x	x	x				OFF
No.8	NONE												
No.9	NONE												
No.10	NONE												

Each Paging event encompasses a single memory slot (1-32). For each event, the following settings may be selected:

1. Displays the **Paging Preset #** (1-32)
2. Selects the **Paging input Source** (only inputs which have been assigned a priority will be available in this list)
3. Indicates **Output Priority** (set in Paging Priority Setting Page)
4. **Priority Mode**- Selects which source will be output when more than one source of the same priority level is fed to the same output(s). **FIFO**-First-In-First-Out, **LIFO**-Last-In-First-Out, **MIX**-All sources are output.
5. **Assigns how the Page will be activated: VOX:** (audio activated-D-001T/R *only*. **Gate must be ON**), **C-IN:** C1-12\* (control trigger), **RMSW:** ZM-9011, ZM-9013, ZM-9014 (page initiate). \*C-IN 1-4 on Mainframe. 5-12 requires C-001T
6. **Assigns the output(s)** to which the page will be routed when activated.
7. Selects whether contact output relay (1-12)\* will be activated in sync with the page activation. This may be used to control emergency lighting, sirens, messaging, etc...

#### ***d. How do I program a Paging Event from the front panel?***

- a. Make certain you have a paging source connected to the D-001T/D-001R module and the parameters (i.e.-sensitivity, EQ, etc....) are set correctly for this source.
- b. In the channel edit mode (described above), go the **PAGE** function.
- c. If this is set to off, select the “ON”
- d. Then select the **PRIORITY** setting page. You may select a priority of 1, 2 or 3 using the parameter knob.
- e. Pressing the “**ENTER**” key takes you to the next parameter, which allows you to select the PAGE memory (1-32) and PAGE OUT (the output to which the page will be broadcast). You may select from any or all of the available outputs by pressing the **OUTPUT Channel ON/OFF** button for each output selected (only those outputs available will appear). A red indicator will appear next to each output to which that paging event has been assigned.
- f. Then, pressing the “▶” arrow takes you to the TRIGGER setting. Here you may select VOX (audio trigger), C-IN or ZM. If C-IN or ZM are selected, using the “▶” again takes you to the next page where either the C-IN port or ZM ID/Switch # may be selected using the Parameter knob. (only ZM-9011, 9013 or 9014 may be used for this function).
- g. If **VOX** is selected, then the outputs may be assigned in the same way as described above in step e. .
- h. The next page set the **PAGE SYNC**, which assigns any of the available contact outputs (1-4 Mainframe, 5-12 w/C-001T) to control external equipment in sync with a paging event. ⓘ
- i. Using the “▲/▼”, select the **DUCKING** parameter. Using the channel select buttons, select each channel and set the ducking level for that channel. This should only be applied to channels with a Priority value of 2 or lower.
- j. Multiple page events may be programmed in this way either from the same source or multiple sources.
- k. When finished, Press MEMORY to store the settings to a SCENE.

**ⓘ For VOX activation (D-001T/R), the Gate function must be turned ON in the GUI software.**

***The 9000M2 control outputs (sync) may be used to trigger playback of a file from a message repeater (such as an EV-20R or S-20S module installed). This would allow the file to have priority paging override capability. Paging activation for the S-20S module may only be triggered using either a C-IN or ZM control and cannot be triggered by VOX. However, a priority message from an EV-20R connected to a D-001T or D-001R may be activated by VOX.***



## 6. Communication with a PC

### a. How do I connect a 9000M2 Series unit to a PC?

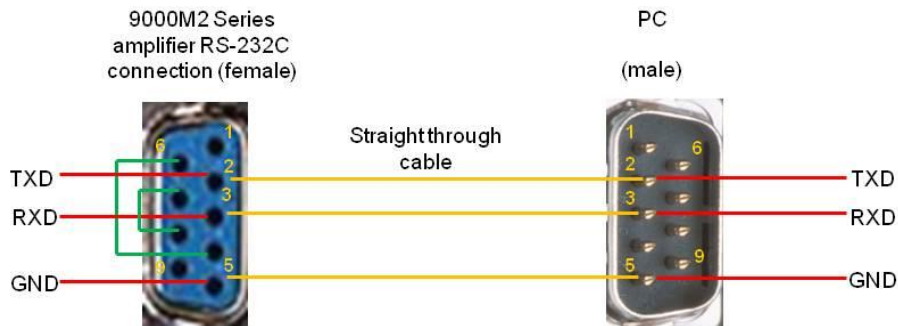

Use a straight-through 9-pin serial cable Male-Female for PC connection. If your PC does not have a serial port (only USB), a third-party USB >Serial adapter should work. However, you may need to check a few, as not all will function reliably due to differences in pin configuration and driver compatibility. Please also be aware that PC issues such as OS, drivers, other software and port settings may affect connection and these settings should also be checked.

### Using the Serial Setup Wizard:

From the Drop-down Menu select:

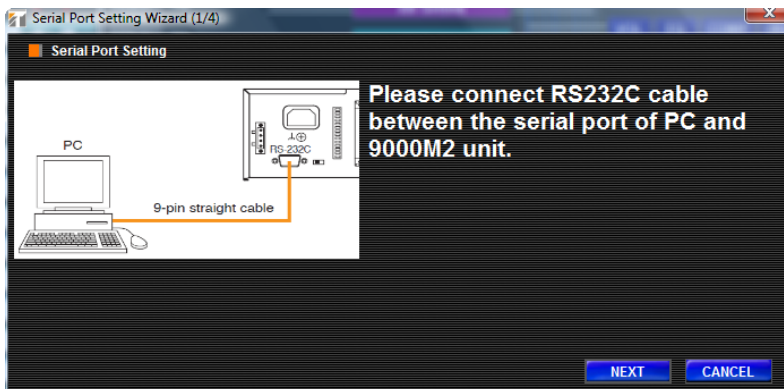
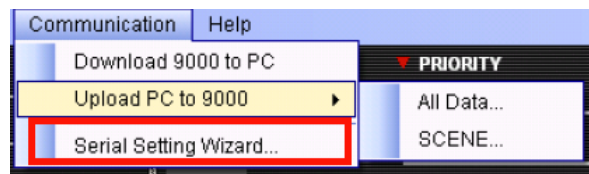

The Serial Setup Wizard will launch:

Click "NEXT":

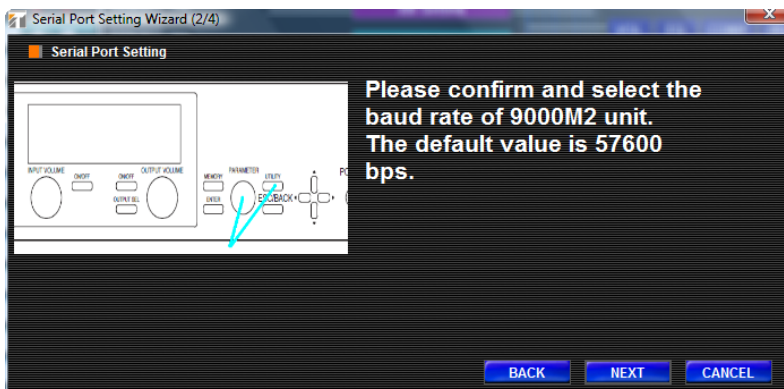

Confirm the serial baud rate of your 9000M2 unit (this may be accessed in the unit's UTILITY menu under RS-232).

Then click "NEXT".

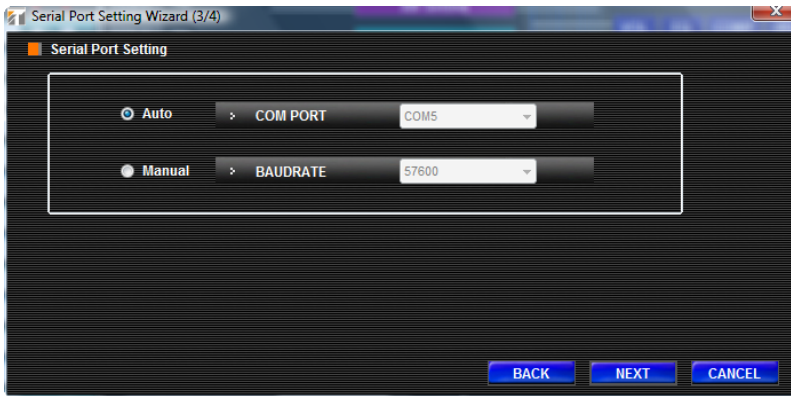

In this window, you may select between AUTO (which test the connection using the default rate), MANUAL (where you may enter a different baud rate). Sometimes, due to differences in PCs (or when using a USB>Serial adapter) a different baud rate may work better than the default. Once selected Click "NEXT"

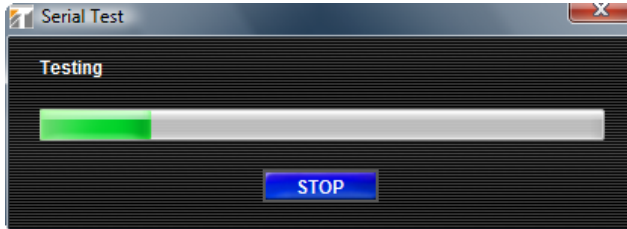

The unit will then go into TEST mode. If the serial connection is OK, it will say "Connection OK" and you may then click "FINISH". If it does not pass, it will say "Connection Failed". Check the cable & serial settings (using a different baud rate) and try again.

## ***b. How do I Upload/Download Configuration presets?***

First, assure that your PC is connected to the 9000M2 unit via the appropriate 9-pin serial cable

### **For Upload:**

- From the "Communication" menu Select "UPLOAD PC TO 9000"
- From here, you may select ALL Data (loads the entire Configuration File-including Scene Memories, Paging Memories and Global/Remote Control Settings). This takes approximately 30 secs. The unit will automatically reset once the settings are done loading
- Or, you can load just a single Scene Memory (1-32). This takes approximately 5 secs. As above, the unit will reset once load is complete.

### **For Download:**

- A configuration template may also be downloaded from a 9000M2 unit for further editing. Simply select the "Download 9000 to PC" to execute this function.
- These procedures can be done directly from the GUI software while the unit is powered on and does not require any "power-up" initialization.

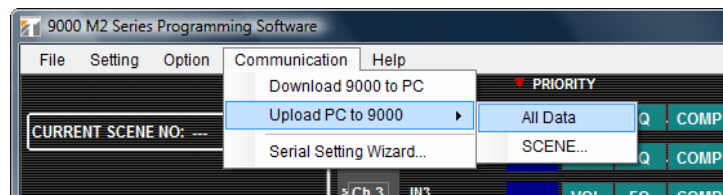

### c. How do I protect my 9000M2 front panel settings from tampering?

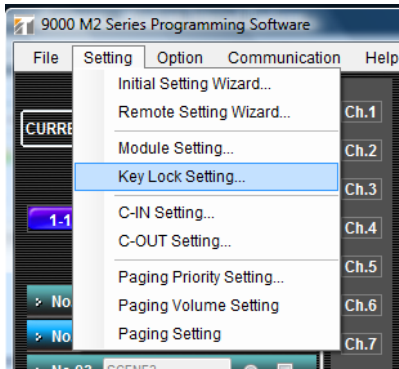

From the Drop-down Menu, select “Key Lock Setting”

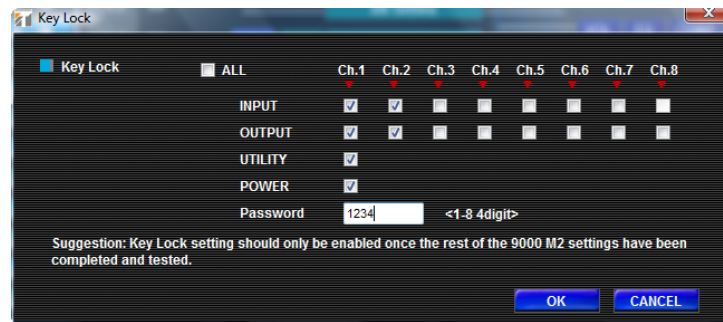

From this window Input & Output Channels, UTILITY & POWER functions on the front panel may be checked for protection. You will then need to enter a 4-digit (1-8) password in the box below. Click “OK”. When the configuration file is uploaded to a 9000M2 unit, these areas will require you enter your 4-digit password (using the numeric channel keys on the front panel) whenever you attempt to access them.

### d. What to do if I've forgotten my security password?

Not to worry. We've provided a back door to getting into the front panel. When you encounter an “ENTER PASSWORD” screen, implement the following button push:

PRESS and HOLD “INPUT 1”, then press the “ESC/BACK” key and the “▲” arrow key simultaneously. This will allow security access to menu functions which had been locked out.

### e. How do I update the firmware on the 9000M2 unit?

First you should check your unit's current firmware version in the UTILITY menu under “Version”.

1. Updated 9000M2 Series firmware (available at: <http://www.toaelectronics.com/downloads/9000M2/Firmware/Firmware.zip>)
2. You will be instructed to save the firmware to your desktop as an .mot file.
3. Connect your 9000M2 unit to a Windows PC via the appropriate serial cable.
4. Be certain you have serial communication between your PC and 9000M2 unit (use the Serial Connection Wizard to test for a good, working connection).
5. From a power off state, Place the 9000M2 unit in “UPDATE MODE” (press & hold the following keys in the indicated order: CH 8 / ESC/BACK / POWER)
6. From the 9000M2 GUI Software Drop-down menu, select OPTION/Update Firmware.
7. The Firmware Update window will appear:
8. Use the “Browse” function to locate the .mot file on your PC's desktop
9. Then select “START”

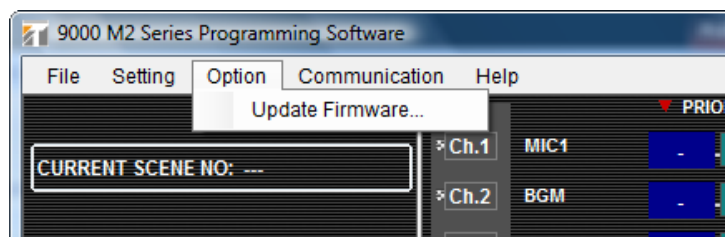

10. When this process is completed, the unit will power down. Upon power-up, it will confirm new firmware rev on the display. This may also be viewed in the UTILITY MENU under “VERSION” (See chapter 8 – C)

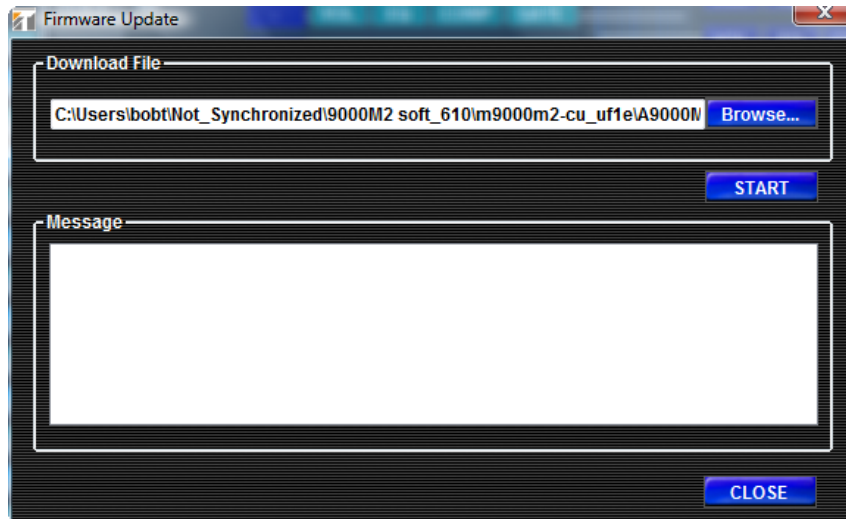

***f. How can I generate a configuration chart to distribute to field techs?***

The 9000M2 configuration file may be saved as a .csv format file using the File EXCEL CSV Format option. This may then be imported into MS Excel or other .csv compatible spreadsheet application. It will display as table delineated text.

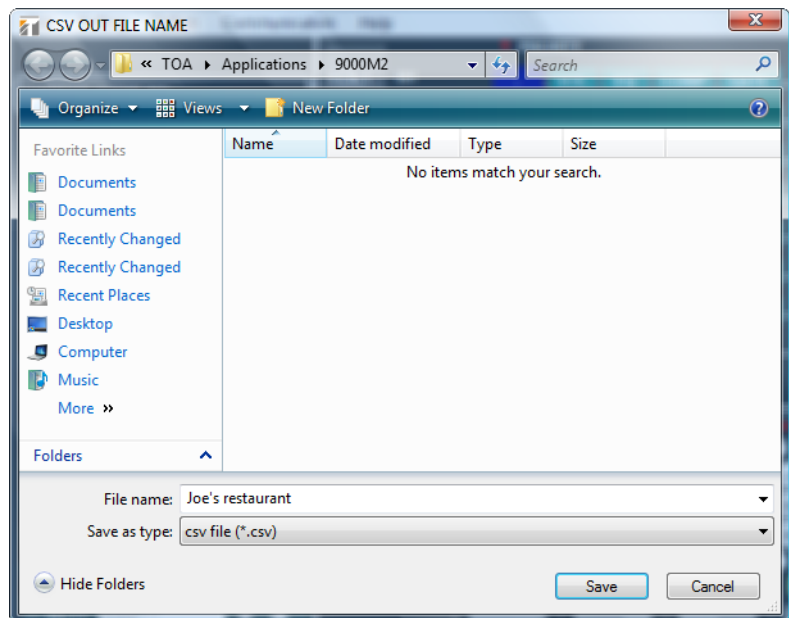
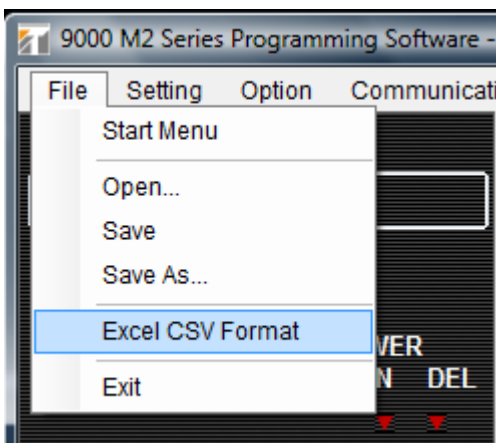

## 7. Controlling the 9000M2 Series

There are several ways of controlling the 9000M2 Series:

1. Front panel
2. Remote Control Option A (Mainframe-Volume Pot, ZM-9001, ZM-9002)
3. Remote Control Option B (RC-001T w/ZM-9011, ZM-9012, ZM-9012, ZM-9014)
4. Contact Closure (Mainframe & C-001T w/ZM-9003, remote contacts)
5. Serial Control (PC, third-party control system)

### ***a. How do I control the 9000M2 Series from the front panel?***

Control of the 9000M2 Series may be accessed on the front panel. However, front panel control is limited to Memory Recall, Volume & Ch On/Off functions. While this sometimes a necessary option (for lack of any external control), it should be noted that control via remote or serial connection is more flexible, convenient and efficient. In cases where the front panel controls need to be secure, the KEY LOCK protection feature may be used to lock out any or all front panel access.

### ***b. How do I control the 9000M2 Series using Remote Volume inputs?***

#### **Remote Option A (Mainframe)**

**Using the two Remote Input 2-wire terminals on the 9000M2 Mainframe:** (ZM-9001, ZM-9002, Volume pot).



**ZM-9001:** This controller operates on one of the 2 two-wire remote inputs on the 9000M2 Series' back panel. This version provides 6 assignable buttons, which may be programmed to control **scene memory selection** or **volume up/volume down** (incrementally) for any input or input channel. The assignments for this control may be found in the Initial Settings page #2 in the GUI or the unit's UTILITY menu.



**ZM-9002:** This controller also operates on one of the 2 two-wire remote inputs on the 9000M2 Series' back panel. This version provides 4 assignable buttons, which may be programmed to control **scene memory selection** or **volume up/volume down** (incrementally) for any input or output channel. It also features a continuously **variable knob**, which may be assigned to control volume. The assignments for this control may be found in the Initial Settings page #2 in the GUI or the unit's UTILITY menu.



**REMOTE (10KΩ pot):** Works with either of the 2 two-wire remote inputs and may be chosen in lieu of the ZM controllers, when only a simple volume control is required. The assignments for this control may be found in the Initial Settings page #2 in the GUI or the 9000M2 unit's UTILITY menu.

*\*Available through other suppliers*

**Note: The ZM-9001 & 9002 remotes cannot be used to select input sources.**

## Remote Option B (Serial RS-485 Using RC-001T)



**RC-001T:** This module is inserted into the 9000M2 frame when the need for more advanced remote control is required. The RC-001T features two serial RS-485 control ports. Each port will allow connection of up to (8) RS-485 remote controllers (shown below) for a total of 16 remotes. Each port must be provided independent DC power via the **AD-246** power supply (available separately). These remotes may be programmed for the following functions:

The buttons on each remote may be programmed for:

- Scene Change (1-32)
- Input Cross-point Value (Exclusive Mode or Simultaneous Mode). Up to 128 combinations.
- Initiate Paging (1-32)
- Change Control Output (1-12)

The rotary knobs may be programmed to control volume for any input or output and may be assigned to control multiple Input or Output channels simultaneously.



**ZM-9011:** This controller may be installed in a single-gang electrical box and fitted with the decora-style plate. The four buttons may be programmed using the GUI software as described above. An LED indicator next to each button shows its current active status. There is also a removable label strip for function labeling of each button. Rear connection is via a 10-pin removable phoenix-style terminal block. Settings for this remote may be found in the Remote Setting Wizard in the GUI software.



**ZM-9012:** This controller may be installed in a single-gang electrical box and fitted with the decora-style plate. The rotary knob may be programmed using the GUI software as described above. An LED indicator next to the knob shows its current level status. Rear connection is via a 10-pin removable phoenix-style terminal block. Settings for this remote may be found in the Remote Setting Wizard in the GUI software.



**ZM-9013:** This controller may be installed in a dual-gang electrical box and fitted with the decora-style plate. The eight buttons may be programmed using the GUI software as described above. An LED indicator next to each button shows its current active status. There is also a removable label strip for function labeling of each button. Rear connection is via a 10-pin removable phoenix-style terminal block. Settings for this remote may be found in the Remote Setting Wizard in the GUI software.



**ZM-9014:** This controller may be installed in a dual-gang electrical box and fitted with the decora-style plate. The four buttons may be programmed using the GUI software as described above. An LED indicator next to each button shows its current active status. There is also a removable label strip for function labeling of each button. The rotary knob may be programmed as described above. An LED indicator next to the knob shows its current level status. Rear connection is via a 10-pin removable phoenix-style terminal block. Settings for this remote may be found in the Remote Setting Wizard in the GUI software.

### c. How do I Connect the ZM Serial Remotes?

The ZM-9011, 9012, 9013 & ZM-9014 are setup in the following way:

#### RS-485 Remote Wiring Scheme

(Recommend CPEV or shielded CAT5 cable -min. dia. .51mm/22ga)

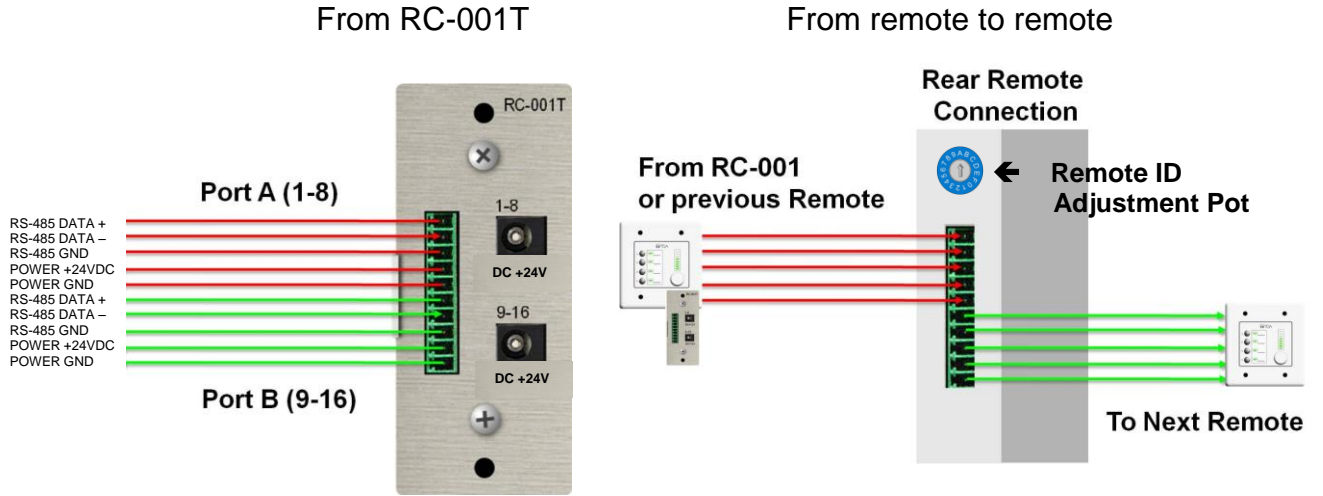

#### Dual Port w/ 8 remotes per port

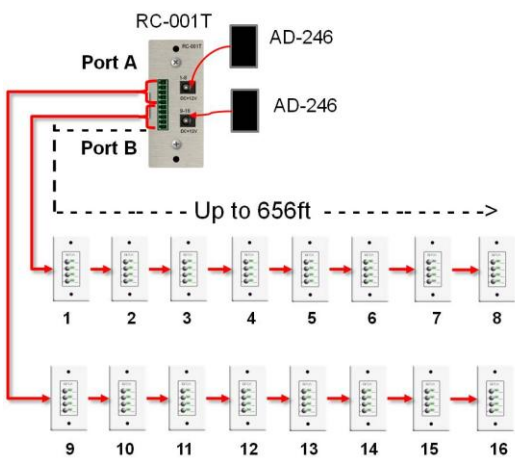

#### Dual Port w/6 remotes per port

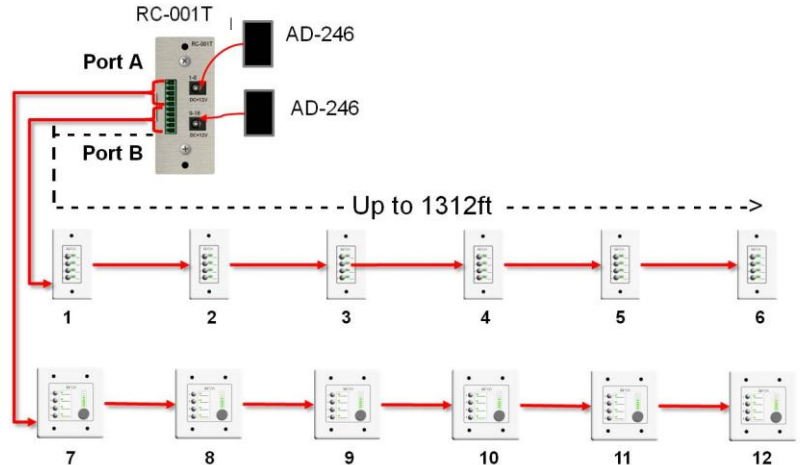

#### Dual Port Star Configuration w/ 8 remotes per port

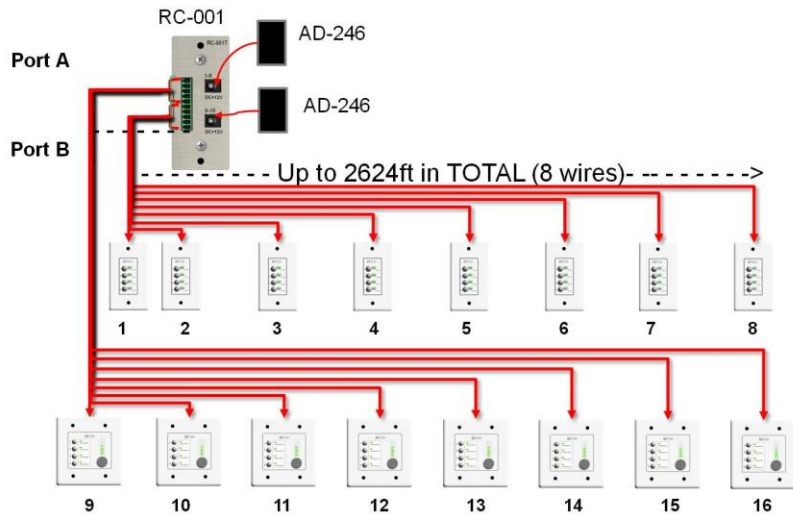

- Max cable length per port (daisy-chain config) 1,312ft w/6 remotes
- Max cable length per port (star config) 2,624ft -total length
- Daisy chain & star may not be combined on a single port, but each may be used per port
- For daisy-chain, it does not matter where the remotes are placed physically, but it does matter what ID they are assigned and in what order they are wired.

### d. How do I set the ZM Serial Remotes to Control Channel Volume?

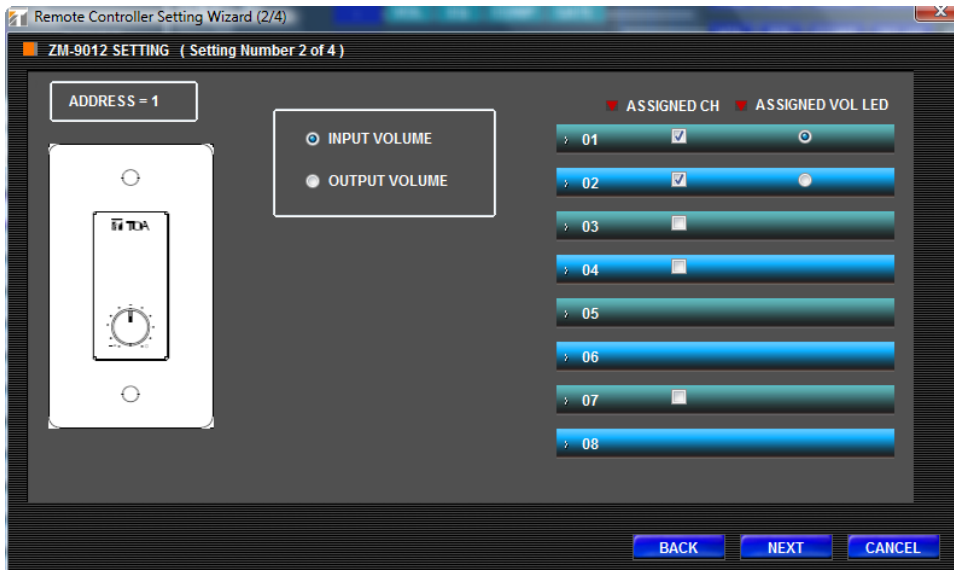

In the **Remote Setting Wizard**, select **NEXT** to scroll through the available remotes until the desired **ZM-9012** or **ZM-9014** appears:

- The remote may be set to function as an **INPUT VOLUME** or **OUTPUT VOLUME**.
- Once this is set, the channel it will control is checked on the right.
- If more than one channel is to be controlled by the remote, then multiple boxes can be selected.
- The **Assigned Volume LED** determines which channel will represent the group and send level information to the remote's LED indicator. However, this will not indicate any offset levels within the group.
- The process for programming the ZM-9012 & ZM-9014 are the same, except the ZM-9014 also has buttons which may be programmed.
- Several ZM-9012/9014 remotes may be used to control different Inputs and Outputs as needed (Max 16)

### e. How do I set the ZM Serial Remotes to Change Scene Memories?

In the **Remote Setting Wizard**, select **NEXT** to scroll through the available remotes until the desired ZM-9011, ZM-9013 or ZM-9014 appears:

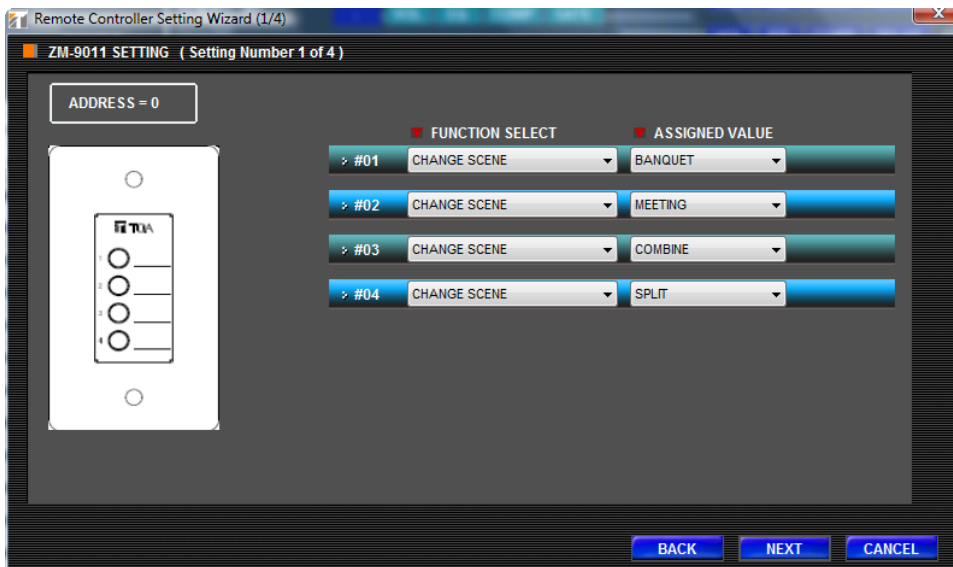

- In the Function Select menu, select **CHANGE SCENE**.
- Once this is set, the **SCENE MEMORY** it will call up can be selected under **ASSIGNED VALUE** on the right.
- The ZM-9011 & ZM-9014 can each be assigned to select 4 **SCENES**. The ZM-9013 can select up to 8 **SCENES**.
- Not all buttons on a remote need to be assigned the same function. Some can even remain unassigned.



## f. How do I set the ZM Serial Remotes to Select Program Sources (Cross-Point Change)?

In the **Remote Setting Wizard**, select **NEXT** to scroll through the available remotes until the desired ZM-9011, ZM-9013 or ZM-9014 appears:

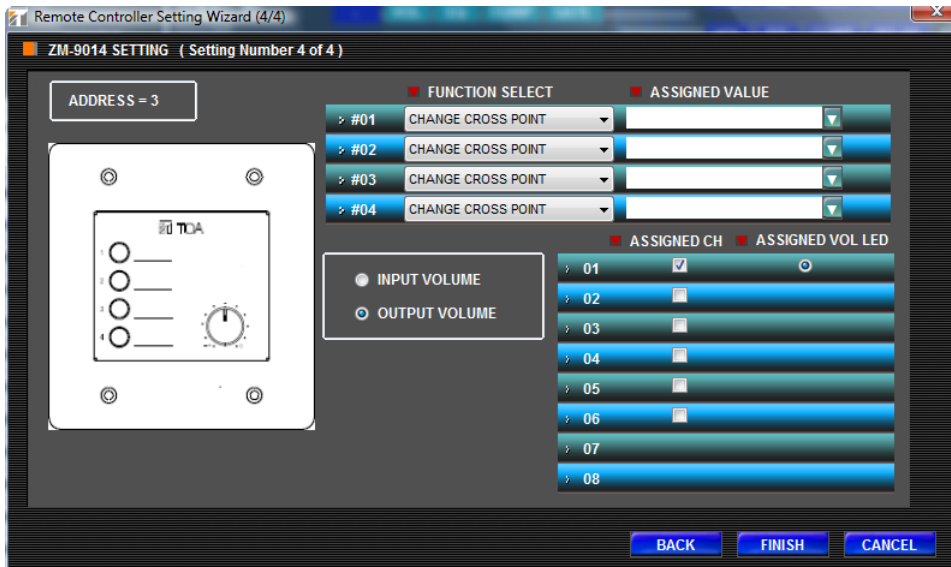

- Under **FUNCTION SELECT**, select **CHANGE CROSS-POINT**
- Then, under **ASSIGNED VALUE**, click the “▼” arrow.
- A matrix assign window will appear. This allows you to select which cross-point value (which Input(s) to which output(s)).
- The assignments

will be different depending on the **SOURCE SELECTION MODE** in the main page of the Remote setting Wizard

- **Exclusive Mode:** This mode allows only **one** cross-point assignment per button.



- In this way, no more than one source may be selected at a time for a given zone using a single ZM controller.
- Each source selected overrides the previous one assigned to that zone.

- **Simultaneous Mode:** This mode allows multiple cross-point assignments per button.



- Using this mode, any number of sources may be assigned to any number of outputs with a single button.
- Each button's assignment may be activated or deactivated independently of the others and multiple button assignments may be activated simultaneously and turned on or off as needed.

### ***g. How do I set the ZM Serial Remotes to Initiate Paging?***

In the **Remote Setting Wizard**, select **NEXT** to scroll through the available remotes until the desired ZM-9011, ZM-9013 or ZM-9014 appears:

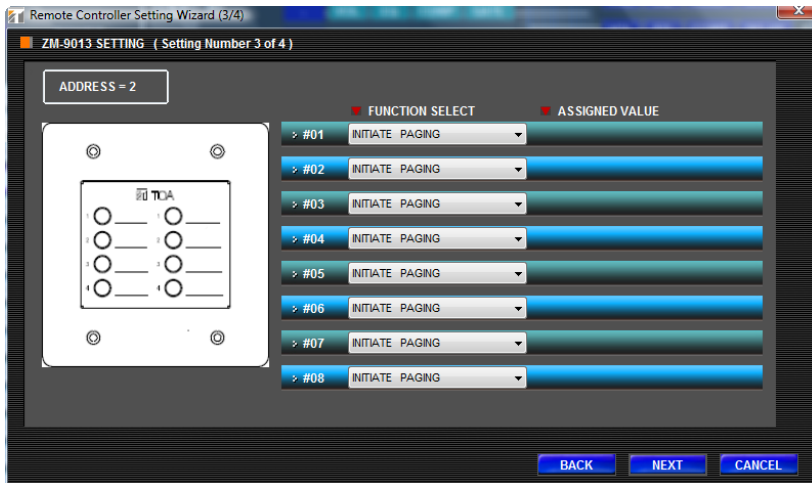

- Under **FUNCTION SELECT**, select **INITIATE PAGING**. This must be done before programming the Paging Settings.
- These buttons will now appear as paging “triggers” in the Paging Settings window.
- The designation will appear as **RMxSWx**. This denotes the remote ID # (0-15) and the switch # on that remote.

### ***h. How do I set the ZM Serial Remotes to Activate Control Outputs?***

In the **Remote Setting Wizard**, select **NEXT** to scroll through the available remotes until the desired ZM-9011, ZM-9013 or ZM-9014 appears:

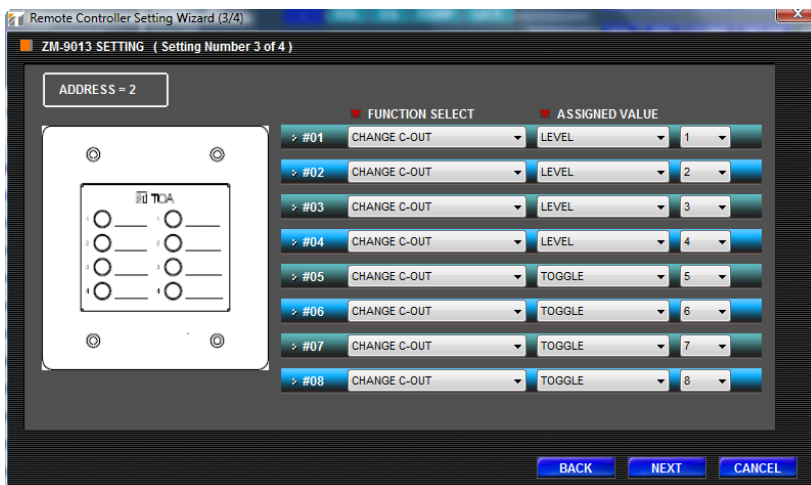

- Under **FUNCTION SELECT**, select **CHANGE C-OUT**
- Then, under **ASIGNED VALUE**, select whether the switch is a **LEVEL** (Press/Hold-activate / Release- deactivate), **-or- TOGGLE** (Press-activate / Press again- deactivate).
- You may then assign which of the available contact outputs to control (1-4: mainframe, 5-12: C-001T). These switches

may be used to control motorized screens, projectors, lighting, message players, access control, CCTV and other remote-controlled equipment.

### ***i. Can the ZM buttons select the source controlled by the volume knob?***

The concept of these controllers is that they should affect only the specific zone’s output volume. The zone volume can be adjusted after the source is selected for that zone. Therefore, the ZM controllers do not control each source’s level.

## j. How do I control the 9000M2 Series using Serial Control?

The 9000M2 Series may be controlled using the 9-pin (RS-232C) serial connection on the rear panel. There are two ways in which this may be implemented:

1. Via a third party controller: AMX, Crestron, etc. RS-232C protocols are available on our website for those who wish to program their own drivers for the 9000M2 Series. AMX & Crestron currently support the 9000M2 Series and control modules are available directly from the manufacturers.  
[http://www.toaelectronics.com/downloads/9000M2/Manuals/9000M2\\_RS232C\\_ProtocolManual.pdf](http://www.toaelectronics.com/downloads/9000M2/Manuals/9000M2_RS232C_ProtocolManual.pdf)
2. Using a Windows PC and either the 9000M2 Series software or the Maintenance software (Virtual Control - \*see below). Using the 9000M2 Series Software provides only limited control access. Certain GUI pages offer an “ADJUST” function, which when connected to a 9000M2 unit via a serial cable provides an audition function. That is, when an adjustment has been made, clicking the ADJUST button on the GUI changes the parameter on the unit to that displayed value. This will not be stored in the unit unless the memory save function is used, or the new setting is saved to a template and then uploaded to the 9000M2 unit.

## k. How do I control the 9000M2 Series using Contact Closures?

### 1. Control In Settings Page (Mainframe, C-001T)

The **CONTROL IN** Settings Page allows programming for the Contact Controllers connected to the CONTROL IN 1-4, 2-wire connections on the 9000M2 mainframe's rear panel & the 5-12 Inputs on the C-001T. A custom dry contact switch or a ZM-9003 controller may be assigned to the following functions:

1. **Parameter** Selects the control function assigned to that contact:

- **LOAD SCENE:** Loads the selected preset SCENE memory
- **VOLUME UP:** Incrementally controls the upward volume
- **VOLUME DOWN:** Incrementally controls the downward volume
- **PAGE TRIGGER:** can activate a priority paging event
- **POWER:** Powers up the 9000M2 unit from STANDBY operation.
- **CHANNEL ON** Turns ON the assigned INPUT or OUTPUT
- **CHANNEL MUTE:** Mutes the assigned INPUT or OUTPUT
- **EMERGENCY MUTE:** MUTES ALL AUDIO
- **PAGING DISABLE:** Prevents paging from any of the available Outputs



2. **CHANNEL/SCENE**-Selects the **Preset Memory** or **Channel #** if Volume, LOAD BANK, MUTE or CHANNEL ON is selected in #1.
3. **STEPS**-Sets the **dB steps** for volume if VOLUME UP/DOWN is selected in #1. The volume will change by this dB increment each time the contact is closed.
4. **SYNC**-Activates a Controller Output (1-12) to be sent simultaneously with activation of that Control IN. This function may be used to facilitate triggering various coordinated events, such as emergency lighting, announcements, cameras, access control, etc...
5. **OK/CANCEL**. Verifies the settings or cancels the operation.

## 2. Control Out Settings Page (Mainframe, C-001T)

The **CONTROL OUT** Settings Page allows programming for the Contact Controllers connected to the Contact OUT 1-4 on the 9000M2 mainframe's rear panel & the 5-12 Outputs on the C-001T. These may be used to control additional 9000M2 units or other devices which operate using contact closures.

1. **Parameter** Selects the control function assigned to that contact:

- **POWER:** (both modes) Sends an active relay signal to that control output when the 9000M2 unit is powered ON
- **LOAD SCENE:** Sends an active relay signal to that control output when the assigned preset SCENE memory is loaded
- **CHANNEL ON:** Sends an active relay signal to that control output when the assigned channel is turned ON

2. Selects the **Preset Memory** or **Channel #** if POWER, LOAD SCENE, CHANNEL ON is selected in #1.
3. Verifies the settings (OK) or Cancels the operation.

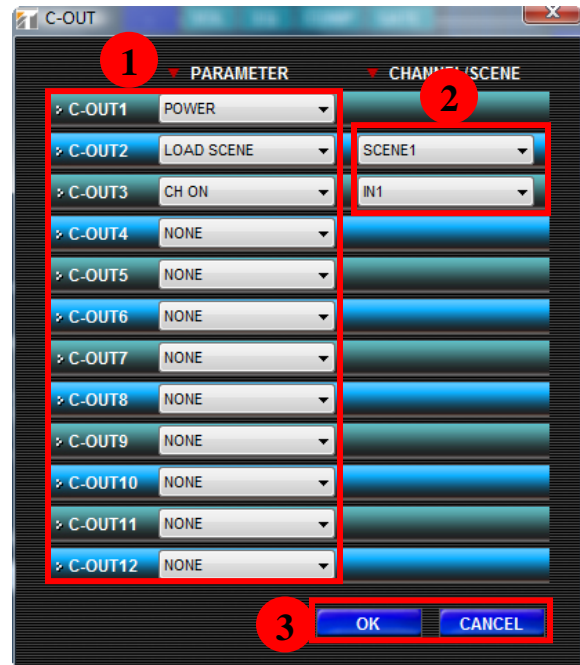

**ZM-9003:** The ZM-9003 controller works with the contact closure inputs on the 9000M2 Series back panel and/or on the C-001T module. It provides a total of 6 buttons-4 locking with label strips (ideal for event/scene memory or BGM source select) and two momentary buttons. These use individual contact (plus a common GROUND) for each of the contact outputs. These may be spilt on the 4 contact INPUTS located on the 9000M2 back panel and those on the C-001T. Because the E (ground) on both of these is internally tied to chassis ground, the E connection on either section may be used. The programming for this may be found in the **MAIN FRAME CONTROL** section of the **GUI** or the **CONTROL IN** page in the **UTILITY** menu. **You may also use a custom-built contact switch or panel for the Control Ins**

***1. How can I check the contact closure functions if I don't have access to switches?***

In the 9000M2 Mainframe, you may access the **UTILITY** menu and using the ▼/▲ arrows, select **C-IN or C-OUT INFO**. This displays which function has been assigned for each terminal. You can also check **C-IN or C-OUT STATUS**. This displays the current active status of each terminal. If the terminal is OPEN, the indication is: "-". If the terminal is CLOSED, the display will be alpha-numeric (0-9, A-C, depending of the terminal 0=terminal 1, C=terminal 12 (if C-001T is installed)).

## 8. Paging with the ZP-001T

### a. How do I perform paging using the ZP-001T?

Once you configure the I/O settings for ZP-001T as the paging source (in this example –SLOT 3/Input 5), you should then:

1. Set the priority for the ZP input as 3 or higher (above the BGM sources).
2. Clicking on the volume calls up the Volume Settings page. The fader adjustment for the ZP module output will appear here and may be adjusted as needed.
3. Clicking on the ZP SETTING box calls up the ZP edit window below. This page allows you to select the type of phone exchange interface you will connect to the module:

#### a. Dial Mode:

1. **Manual:** Operates ZP paging by manually dialing the individual zone(s)
2. **Auto:** Automatically dials the pre-assigned zone(s)
3. **Group:** Manually dials and pages to the pre-assigned groups, each of which may consist of any or all available zones

#### b. Operating Mode:

1. **PAGING PORT**-an analog 2-wire port found on many phone system exchanges. This also requires a dry contact to activate the page.
2. **RING SIGNAL**- An extension output from the phone exchange (typical RJ-11 modular connection-this is for **analog** extension ONLY-NOT compatible with digital signals).

Both of these must support **DTMF** dialing protocols to operate properly (please check the specifications for the exchange)

- Pre-Announced Tone**-selects whether a “chime” precedes the page when activated.

- Connect Time:** Determines the amount of time the page port may remain open before disconnecting. Setting is either 30 sec or 10 mins. Otherwise, you must press “0,0,#” to disconnect the page.

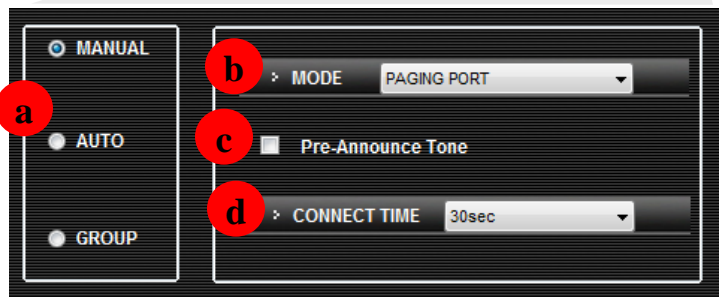
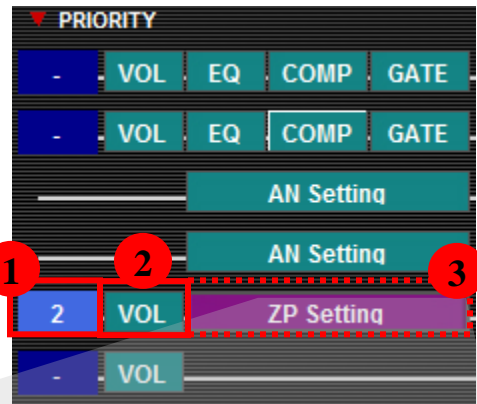

The **ZP-001T** paging functions works very similarly to the normal paging function, except that the Output routing is determined by the DTMF dialing codes. These operate differently depending on the mode selected:

**Manual Mode:** Checking this mode allows the ZP-001T to execute paging by manually dialing and paging to pre-assigned zones.

- The ZP input must first be selected as a priority paging source in the PAGING SETTINGS window. The priority is set in the PAGING PRIORITY window (default-2). No other settings are necessary.
- The ZP module may only be entered once as a paging event in the PAGING SETTINGS window when in this mode**

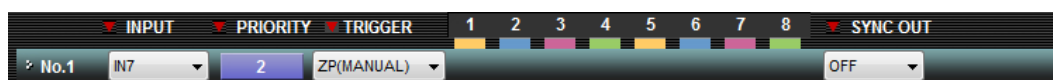

- c. Dial “0”. The rings the extension port on the exchange
- d. Then dial “1-8 (corresponding to the # of the output channel(s) or 9 (for ALL ZONE PAGE). This routes the page to the appropriate zone(s).
- e. Then, dial “#” to execute the page. If the pre-announce tone is activated, it will sound prior to the page being broadcast.

**Auto Mode:** This mode sends the page to the pre-programmed zone or zones, set in the PAGING SETTING window

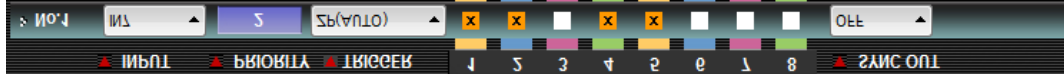

- a. The ZP input must first be selected as a priority paging source in the PAGING SETTINGS window. The priority is set in the PAGING PRIORITY window (default-2). The outputs to which the page is to be routed must then be selected.
- b. Activating the page only requires you to pick-up the telephone’s handset. The dialing commands will be issued automatically (hands-free).
- c. In this example, the page is output to zones 1, 2, 4 & 5 as entered in the paging output assign matrix.
- d. **The ZP module may only be entered once as a paging event in the PAGING SETTINGS when in this mode.**

**Group Mode:** This mode functions similarly to the Manual mode, but instead of “dialing” individual zones, the ZP is programmed so that each number represents a pre-programmed zone “group”.

	INPUT	PRIORITY	TRIGGER	1	2	3	4	5	6	7	8	SYNC OUT
No.1	IN7	2	ZP(GROUP1)	x	x							OFF
No.2	IN7	2	ZP(GROUP2)			x	x					OFF
No.3	IN7	2	ZP(GROUP3)					x	x			OFF
No.4	IN7	2	ZP(GROUP4)							x	x	OFF
No.5	IN7	2	ZP(GROUP5)	x	x			x	x			OFF
No.6	IN7	2	ZP(GROUP6)			x	x			x	x	OFF
No.7	IN7	2	ZP(GROUP7)	x		x		x		x		OFF
No.8	IN7	2	ZP(GROUP8)	x	x	x	x	x	x	x	x	OFF

- a. Once this mode is set in the ZP window, the page assignments must be selected in the PAGING SETTING window:
- b. Each group is programmed with a different output or group of outputs. There are 8 assignable groups in all. Each group is programmed as a separate paging preset.
- c. The dialing commands “0, 1-8 & #”, would execute the page as in Manual mode, but now by dialing “1”, Group 1 receives the page (outputs 1 & 2). There is no 9=All Page as in Manual Mode. However, any group may be set as an ALL ZONE PAGE (as with Group 8 in the example above).

**Note: In any of the dialing modes, the PBX extension # (which represents the ZP module) must be programmed into the phone system and dialed prior to the commands described above. Please consult your telephone system administrator for more information.**

## Example of Manual Dial Mode:

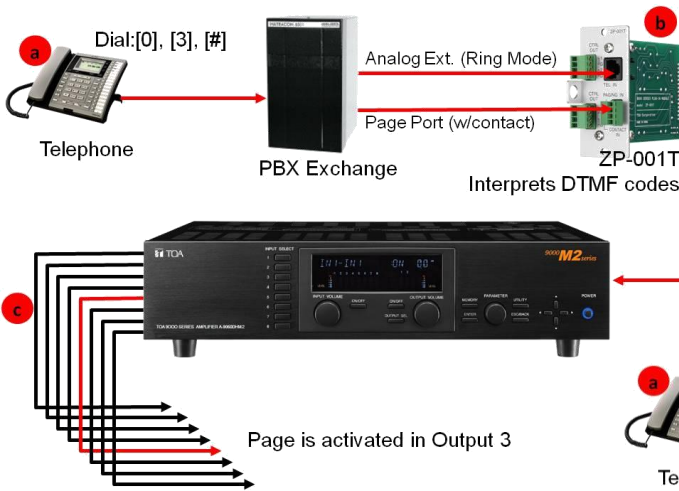

## Example of Group Dial Mode:

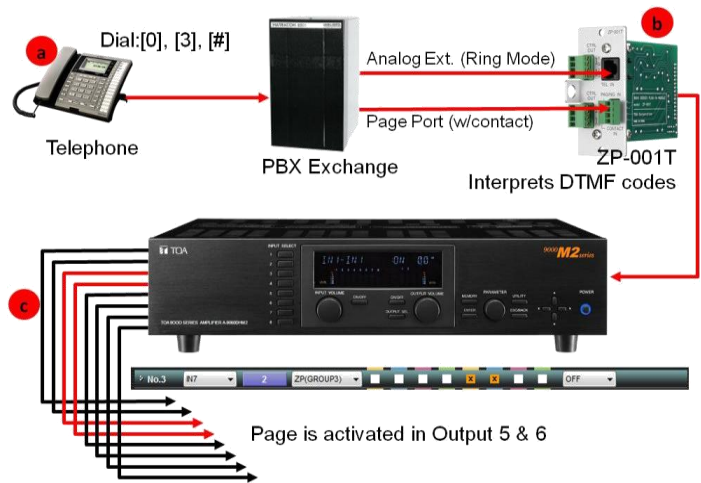

### \*Paging during power-OFF

The power switch located on the amplifier front panel is a soft-switch, and not a mechanical switch and does *NOT* turn the power supply's primary side on or off. Therefore, there is enough internal power to maintain an active microprocessor inside the unit, even if the power switch is set to OFF.

The following controls can be performed when the power is OFF:

- Remote power control by control input: Power can be switched on and off using the external contact.
- Event activation by control input: Turns on the unit's power and activates the assigned Event (Trigger-set Event having the input with Priority 1 – 7) using the external contact. The unit returns to power-OFF state after Event operation completion.
- Paging by the ZP-001T turns on the unit's power. The unit returns to power-OFF state after paging completion.

## b. How do I determine when to use Paging Port Mode or Ring Signal Mode?

### • Paging Port Mode:

- To be used when the PBX system provides an audio line level paging port also passing the DTMF touch tone signals.
- The PBX system is also required to provide no-voltage make contact (contact closure) during paging calls.

### • Ring Signal Mode:

- Used when the PBX system provides an “Analog Extension Port” consisting of an analog two-wire extension line with loop start.
- DTMF signaling is required with 120 IPM reorder tone and 24VDC or more loop voltage.
- Loop voltage supply shall not be cut off from the beginning of a call to the reorder tone out.
- The state of CPC (Calling Party Controlled) break or “Open Loop Disconnect” shall be reset at the PBX.

- The ZP-001T cannot be used with “Pulse Dialing” type PBX.



### c. How do I accomplish multi-zone paging if I have only one output?

The optional **SS-9001** Speaker Output Switcher can selectively switch a single power output to one or more of the four speaker outputs by way of the contact outputs on the 9000M2 mainframe. Use the Paging Event SYNC function. *Only one contact may be assigned per page.* However, up to 4 page events can activate speaker outputs at one time.

- a. **Page Only:** When only **one** output is used (A-9060S, A-9120S, A-9240SH).

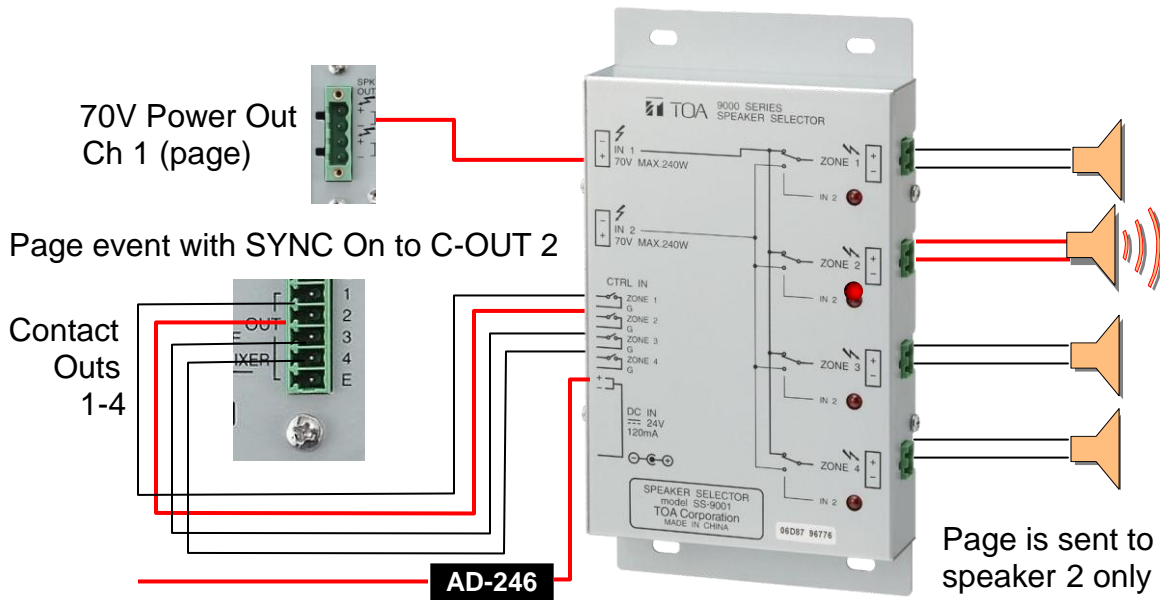

The relay for **speaker output 2** is closed and the page is received from that output.

- b. **BGM/PAGE:** when used with 9000M2 having only the **two** Mainframe outputs (One for BGM & one for PAGE) A-9060DHM2, A-9120DHM2.

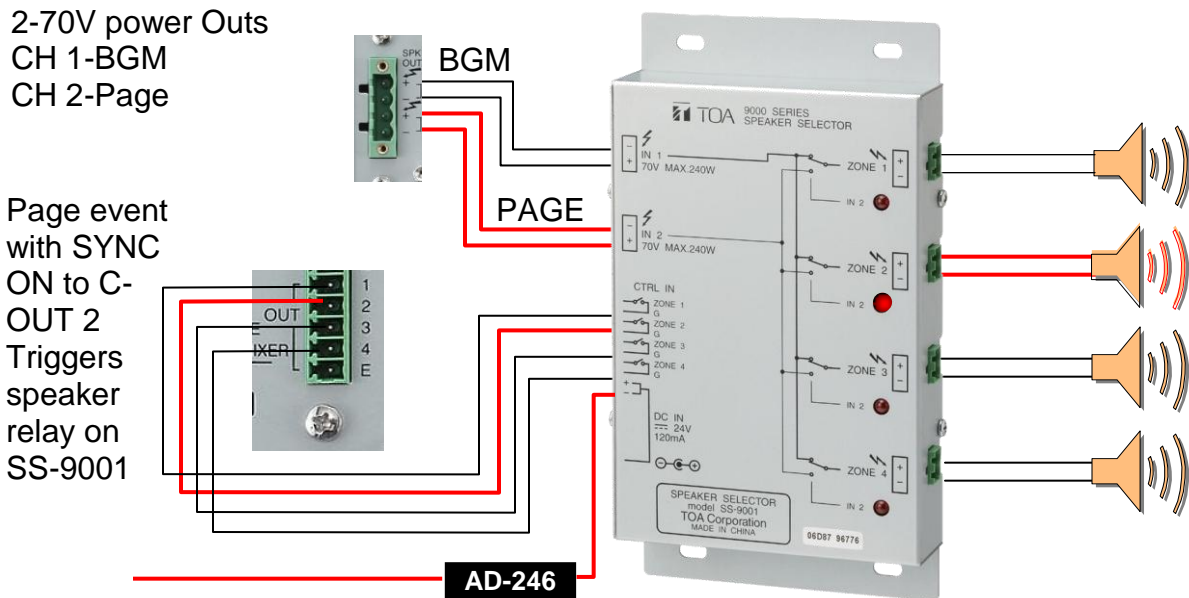

Relays for **speaker output 2** is switched and only this output receives the PAGE, while output 1, 3 & 4 continue to receive the BGM source.

## 8. Ambient Noise Control Using the AN-001T

### a. How does the AN-001T work to compensate for ambient noise?

The **AN-001T** allows the 9000M2 to automatically adjust the level of Background Music in response to a change in level of ambient noise in the environment.

- It does this by way of a sensing microphone (AN-9001), placed in the ceiling or wall and calibrated to sense the room's ambient noise level (done automatically on power up).
- When the noise increases to a preset threshold level, for a specified time window, the AN-001T's sensing circuit can adjust the output level of background music by a predetermined ratio (see graph below).
- Two AN-001T modules may be installed in the 9000M2 frame (see "Hardware Configuration") and a total of 4 AN-9001 sensing microphones may be deployed to sense the ambient noise in independent zones or spread over a large single zone to achieve better coverage.
- Each AN-001T channel may then be assigned to control the level of different outputs.

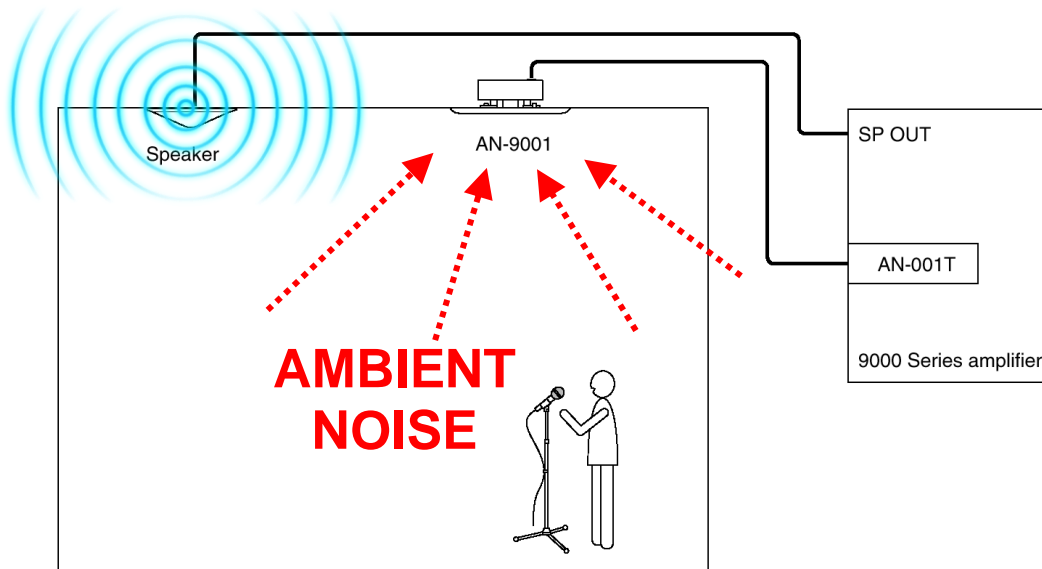

**ⓘ Despite the effectiveness of this function, it is not flawless. Sensing microphones placed too close to a speaker may cause the mic to interpret the speaker's output as additional noise and will trigger a volume change. To help avoid this, care should be taken with respect to mic vs. speaker placement, especially in larger open spaces. Some experimentation will likely be necessary to find the optimum placement.**

**AN-001T settings are saved with the preset Scene or Matrix template. However, ambient noise sense levels will be lost when switching scenes or powering the unit OFF/ON. The AN sensing will need to recalibrate to the current environment when the unit again becomes active after memory change or power up.**

**The AN-001T does not affect the Paging Volume, but only the normal Output Level (determined by either Scene change or manual adjustment.) The paging sources will be output at their pre-programmed levels.**

**b. What settings should I use for the AN-001T?**

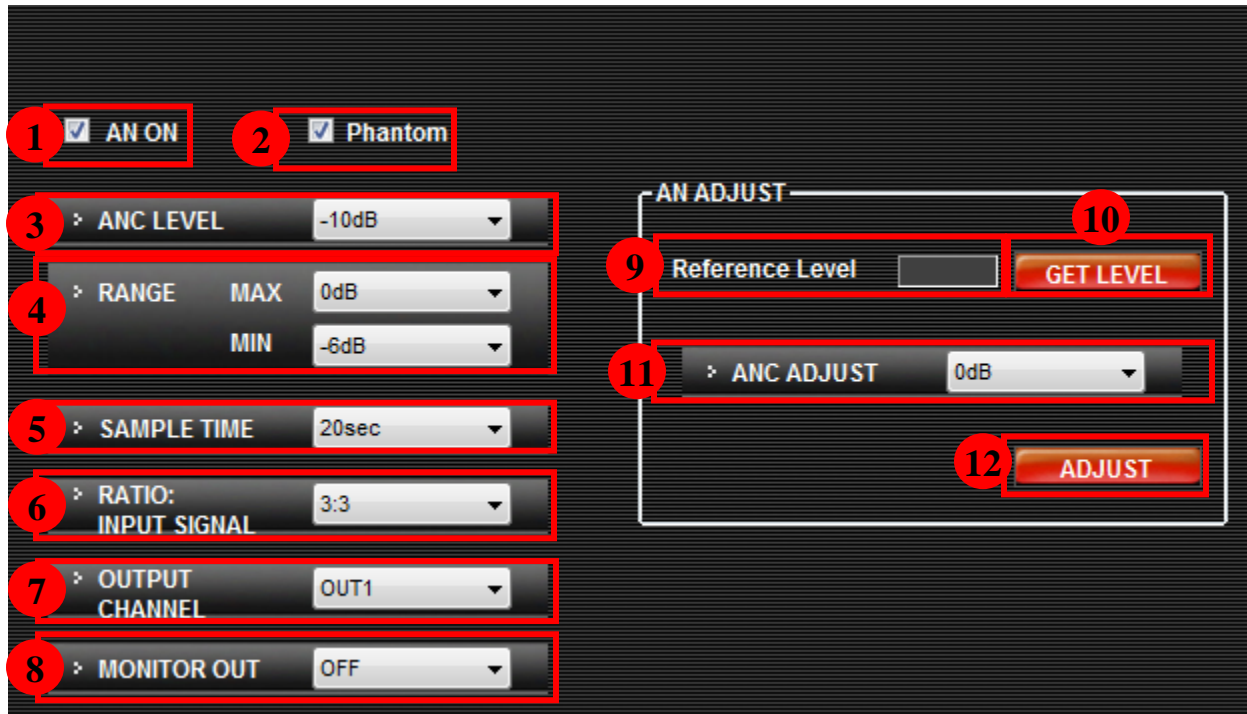

It should help to explain what each setting does and then how to apply it:

1. **AN ON**- Turns the AN-001T sensing function on for that channel. **Note:** Each AN-001T incorporates 2 channels of ANC processing.
2. **PHANTOM**: Turns on a 24VDC phantom power supply required by the AN-9001. While other (non-phantom) mics may be used for this function, the AN-9001 is optimized to perform with this module.
3. **ANC LEVEL**: Sets the noise sensing threshold. This is the level at which the AN circuit responds to the incoming noise. This should be at or above the level of background music.
4. **RANGE**: **MAX**-Sets the maximum level which the AN circuit can adjust to. **MIN**- Sets the minimum level the AN circuit will adjust to. This function acts somewhat like a "LIMITER" prevent the output from becoming too loud or too low.
5. **SAMPLE TIME**: Sets the minimum amount of time the ambient noise level must exceed the sensing threshold in order for the AN circuit to have any effect. This is used to prevent "false" triggering by intermittent or transient sounds, such as a brief loud noise or someone shouting.
6. **RATIO: INPUT SIGNAL**: Sets the ratio for the number of dB of input (noise) and the resulting change in dB of output.

- a. For example: A 3:3 ratio (default setting) means that for every 3 dB of noise input increase, the output level of the background Music is increased by 3 dB.
- b. A negative ratio may also be chosen. This has the effect of decreasing the output level in response to an increase in noise level. A restaurant or nightclub owner may decide that, if the conversation at the bar is getting louder, they do not want the background music

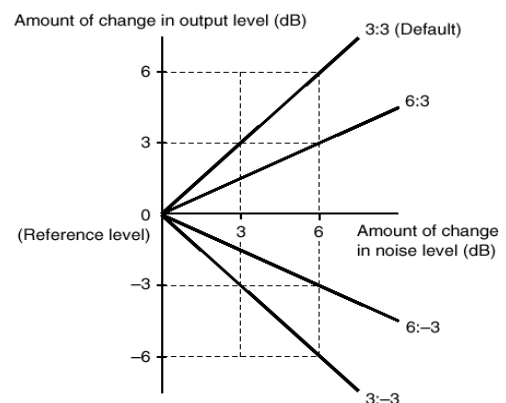

to compete with it (since after all, conversation is what being at the bar is all about). Therefore the music level is automatically lowered rather than raised.

7. **OUTPUT CHANNEL:** Set the output channel to be controlled by that channel of the AN-001T. As previously mentioned, several AN channels may be set to control different output channel levels.
8. **MONITOR OUTPUT:** An unused Line Output on the 9000M2 may be assigned as a monitor to a security office amp/speaker. While the audio picked up by the sensing mic is not meant to be fed through the main speakers, it may serve to allow security guards to “listen in” on unauthorized activity.
9. **REFERENCE LEVEL:** Displays the current reference level after the GET LEVEL button is activated. Reference Level for the AN-001T is used for fine tuning – if you are getting larger numbers (realistically 10 or above) – adjust the settings of your AN-001T module and then try again.
10. **GET LEVEL:** With an AN-9001 mic connected to the AN-001T (and with AN & Phantom turned on as described above), Click the “GET LEVEL” button. This displays the AN reference level in the Reference Level box.
11. **ANC ADJUST:** Using the ANC ADJUST combo box, adjust the ANC value so that the reference level becomes "0." Increase the ANC adjustment value when the reference level is higher than 0, and decrease when it is lower than 0.
12. **ADJUST:** Click the ADJUST button, and the set value is stored to the 9000M2. Repeat this procedure from the beginning until the reference value becomes nearly “0.”

## 10. Miscellaneous

### a. How do I troubleshoot the 9000M2 Series?

Symptom	Possible Cause	Remedy
Noise generated.	Module mounting screw not securely tightened.	If this screw is loose, noise may be produced. Ensure that the screw is tightened.
Excessive noise.	Incorrect module input sensitivity setting.	The unit is designed to digitize audio signals with an AD converter and vary the input level with a digital volume control. Therefore, noise increases if the input or output volume control is set to a level higher than 0 dB while the AD converter input is kept low.
Sound distorted.	Incorrect module input sensitivity setting.	The unit is designed to digitize audio signals with an AD converter and vary the input level with a digital volume control. Therefore, when an extremely large input is fed into the AD converter, the voice remains distorted even if the volume is decreased.
Phantom power not supplied.	D-001T module mounting screw not securely tightened. (D-001R cannot supply phantom power irrespective of its ON/OFF setting.)	If this screw is loose, phantom power is not supplied. Ensure that the module mounting screw is tightened.
	Phantom power set to OFF in D-001T module input setting. (D-001R cannot supply phantom power irrespective of its ON/OFF setting.)	If phantom power is set to OFF in D-001T module input setting, phantom power is not supplied. Set phantom power to ON in the input setting.
Condenser microphone does not operate correctly.	Condenser microphone of the type powered by over +24 V is used.	The D-001T module's phantom power supplies +24 V. If using a condenser microphone powered by over +24 V, separately prepare phantom power supply equipment recommended by the equipment manufacturer.
Amplifier malfunctioned (does not operated as intended.)	Incorrect item or parameter setting.	Check the related setting items and set contents.
Only a part of the settings does not work correctly.	Incorrect type of module selected or module inserted into incorrect slot.	Check the related setting items and set contents.
Zone manger and Remote control panel do not work.	Incorrect type of Zone manager or Remote control panel selected or incorrect ID set.	Check the related setting items and set contents.
	A higher-priority broadcast in progress.	A higher-priority broadcast being made when the indicator of the paging activation function-assigned SW flashing.

**b. What happens if I unplug the power cord or power is lost?**

- Of course-the power goes out. However, assuming the Firmware is version 1.0 or higher, the 9000M2 Series will retain its settings (memories-scenes, events, etc...). For restoration of power, the unit may be set to either:
  - a. Return to its last status before it lost power...
  - b. Default to a specific memory preset (scene) upon having power restored.

**c. What do the error messages mean?**

Error indications	Possible cause and Remedy
MODULE SLOT#No. ERROR	A module is inserted into a wrong slot. Check to confirm that each module is inserted into a correct slot, and correctly reinsert the module inserted into the wrong slot. (Refer to <a href="#">p. 104 "MODULE INSTALLATION."</a> )
DC PROTECT (OUTPUT #No.)	There may be overload or excessive signal input. Check input and output signal levels and gain settings, then adjust them as necessary. If the indicator remains lit, consult your TOA dealer.
THERMAL PROTECT	The unit is heated to a high temperature. Check that the unit is properly installed. (Refer to <a href="#">p. 11 "INSTALLATION PRECAUTIONS."</a> ) Disconnect the AC cord from the unit, and allow the unit to cool for a while. The unit automatically resumes operation when its inner temperature decreases. If this happens frequently, contact your TOA dealer.
INITIALIZE MEMORY?	Module-to-Slot configuration was changed or a module was damaged. Perform any of the following operations: (1) Press the Enter key. The set parameter in question is reset to the default setting. (2) Press the Memory key. The unit continues to start up. After start-up is completed, back up the set parameters using the supplied software, then confirm the setting in question to correct. (3) Press the Escape/Back key. "MODULE SLOT#No. ERROR" appears indicating the error slot. Reinsert the correct module into the slot.
The Fault indicator lights.	A communication error between the unit and module occurred. Disconnect the AC power supply, then reconnect it. If the indicator remains lit, this may indicate a unit failure. Consult your TOA dealer.
The Fault indicator flashes.	A setting error occurs and a part of or entire data are initialized. The indicator goes off by pressing the arrow key, Input selection key, or Output selection key. Reconfirm the set data.
The Fault indicator continues to flash.	A communication error between the RC-001T Remote and Remote control panel occurred. Check the cables and remote control panel's setting.

\*Also check that ZM modules have correct ID

## d. Block Diagram

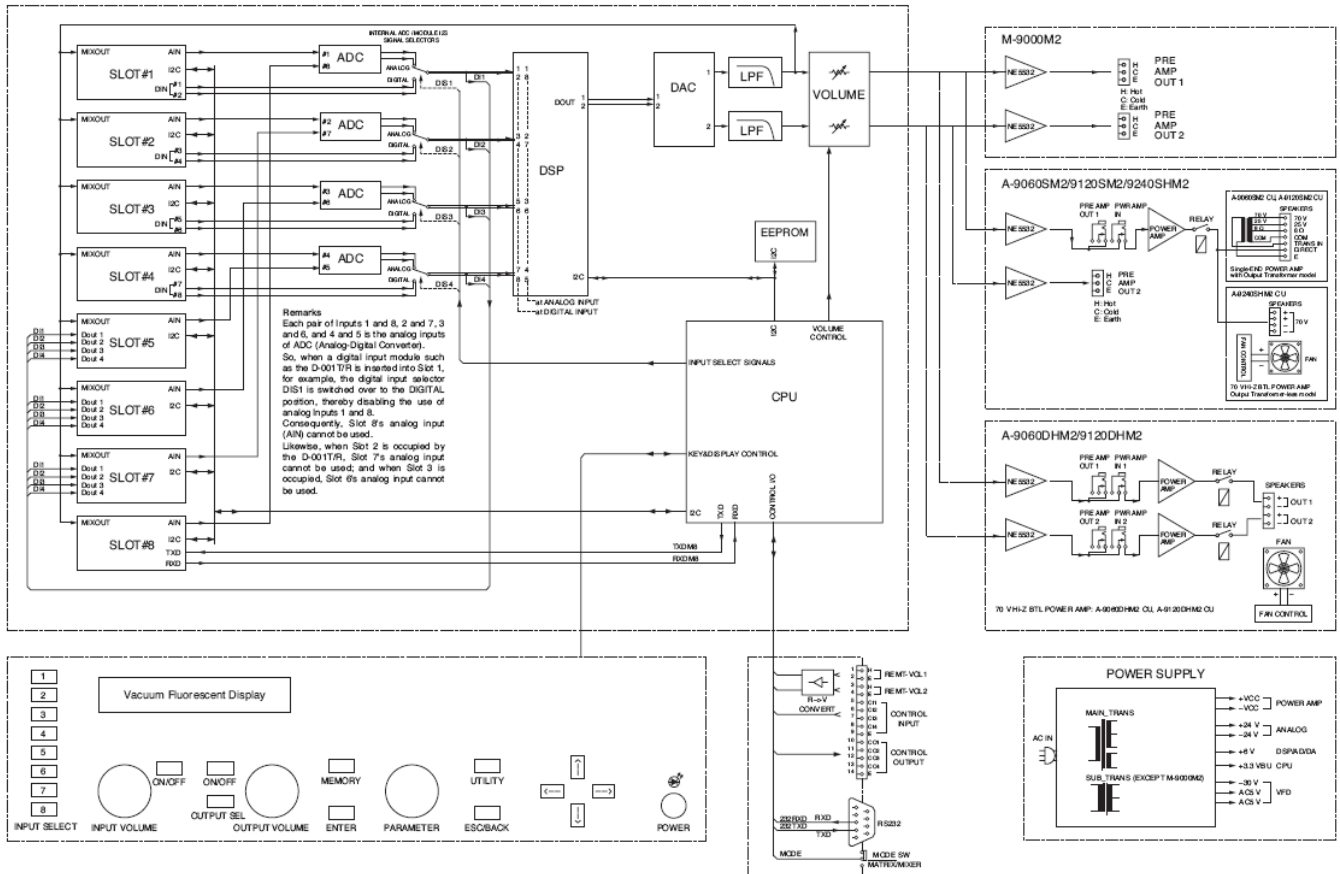

## e. Signal Flow Diagram

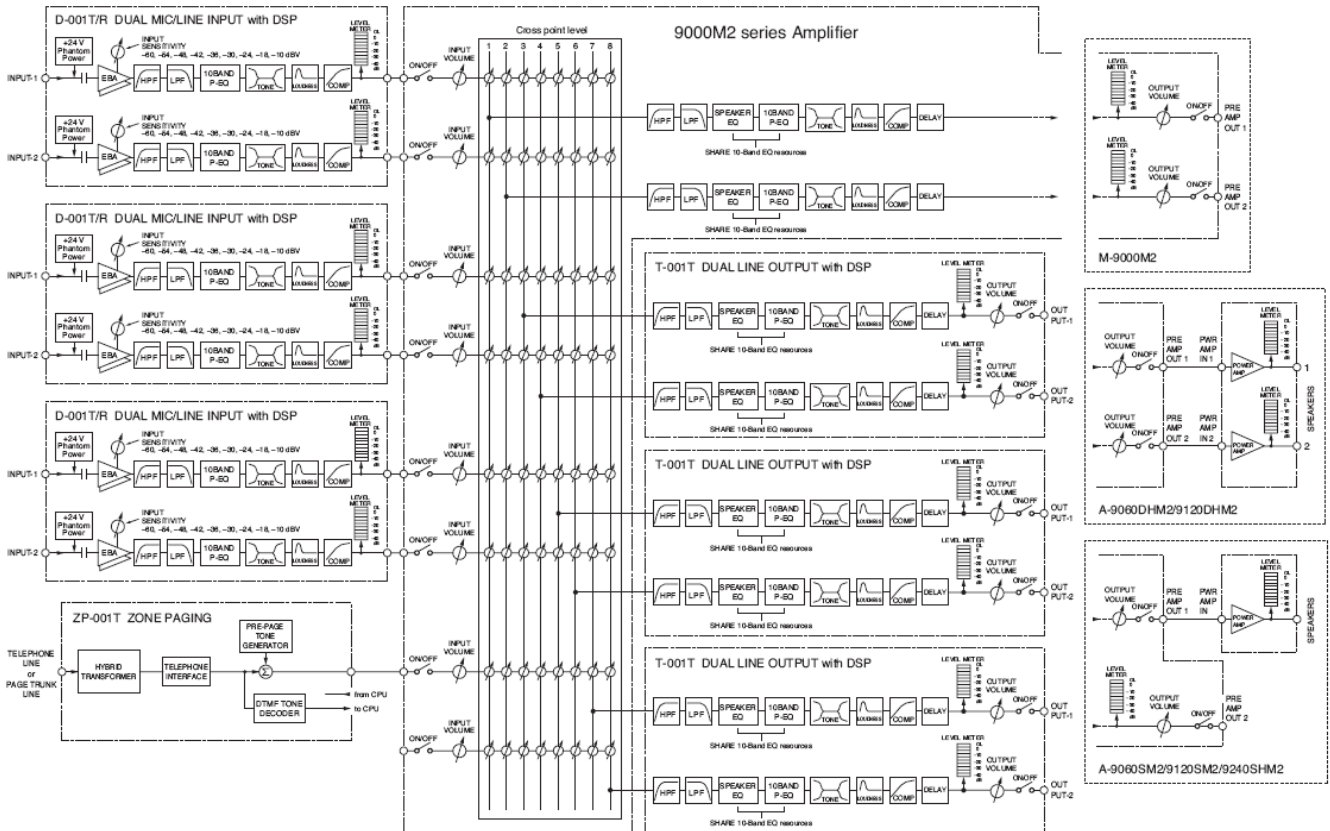

f. NOM TABLE:

NOM	xlogNOM				
	0	3	6	10	20
1	0.0	0.0	0.0	0.0	0.0
2	0.0	0.9	1.8	3.0	6.0
3	0.0	1.4	2.9	4.8	9.5
4	0.0	1.8	3.6	6.0	12.0
5	0.0	2.1	4.2	7.0	14.0
6	0.0	2.3	4.7	7.8	15.6
7	0.0	2.5	5.1	8.5	16.9
8	0.0	2.7	5.4	9.0	18.1



## g. Where can I find additional 9000M2 Series Support Resources?

Log on to: <http://www.toaelectronics.com/amp0011a.asp>



[9000M2 Brochure](#)

Brochure .pdf (1.99 Mb)



[9000M2 Operations Manual](#)

Ops Manual .pdf (9.10 Mb)



[9000M2 Software Manual](#)

Soft Manual .pdf (3.84 Mb)



[Programming Software v1.0 for MS Vista & XP](#)

(Included: .NET Framework v3.5. Requires 9000M2 Series hardware, not compatible with original 9000 Series.)

V 1.0 Software (ZIP, 1.7Mb)

### Remote Control Protocol



[9000M2 RS-232C Protocol v1.00](#) (PDF, 485kb)

NOTE: Protocols are compatible with v1.0 firmware or higher

### 9000M2 Series Remote Control Partners



[Firmware v1.01](#) (ZIP, 477Kb)

(required to use new 9000M2 Series Programming Software, included with software download).

\*Updated firmware not yet posted may be available through product support.

### Other Resources

[Application Guides](#) (PDF, 62kb)

[A&E Specification](#) (TXT, 93kb)

[CAD Data](#) (ZIP, 3.5Mb)

Product Support: Mon-Fri 8:00am-5:00pm PST

1 (800) 733-4748

## 11. Glossary of Terms

- **ANC (Ambient Noise Control) function (AN-001T only)**

The ANC function automatically adjusts the amplifier's output volume in response to the change in ambient noise level. The output volume changes as the ambient noise level goes above or below the set reference level.

- **Cross-point Value**

Sets the output channel(s) to which an Input source is routed. This can be set for non-priority (i.e.-BGM), in the Scene Setting window, or for a paging source in the Paging Setting window. For non-priority sources, the Cross-point Volume adjusts how much of that channel is fed to the assigned output(s). Cross-point assignments are also found in the RS-485 ZM remote button program settings. This is used to select sources in specific zones via remote.

- **Ducker function**

The Ducker function automatically attenuates input signals with lower priority when two or more audio signals are simultaneously received. This function cannot be used if any of such received inputs is not set for the Ducker function.

- **Gate function**

The gate function allows the input signal to be passed, attenuated or cut depending on its signal level. The gate allows the signal to pass when open with the signal level over the set value, and to be attenuated or cut when closed with the signal level below the set value. The Gate function must be activated for VOX paging function to take place.

- **NOM (Number of Open Microphones) attenuation function**

The NOM attenuation function automatically adjusts an output gain depending on the number of open microphones. The output gain is attenuated by the value set on the Utility setting screen each time the number of open microphones doubles. This function helps to prevent feedback.

- **Paging Priority.**

A group of paging output destinations is referred to as "Paging group." Up to 32 paging groups can be saved independently of the Scene memory. Each one of input and trigger, a combination of up to 8 output channels, and interlock output ON/OFF can be set per paging group.

- **Scene**

A "Scene" is the unit that defines broadcast pattern and up to 32 types of Scenes can be saved as a Scene memory. Input and output parameters that have been set can be saved in the Scene memory and recalled as needed.

- **VOX (Voice Operated Exchange) function (D-001T/R only)**

This function activates the set Page event when an audio signal is input. In this trigger mode, no Page is activated when no input signal exists. If the audio signal drops below a preset level after the VOX function begins operation (i.e. after an audio signal is fed into the module), the Page is terminated after approximately 5 seconds.



**TOA Electronics, Inc.**  
**1350 Bayshore Hwy Ste. 270**  
**Burlingame, CA 94010**  
**Tel: (800) 733-4750**  
**Fax: (800) 733-7088**

