

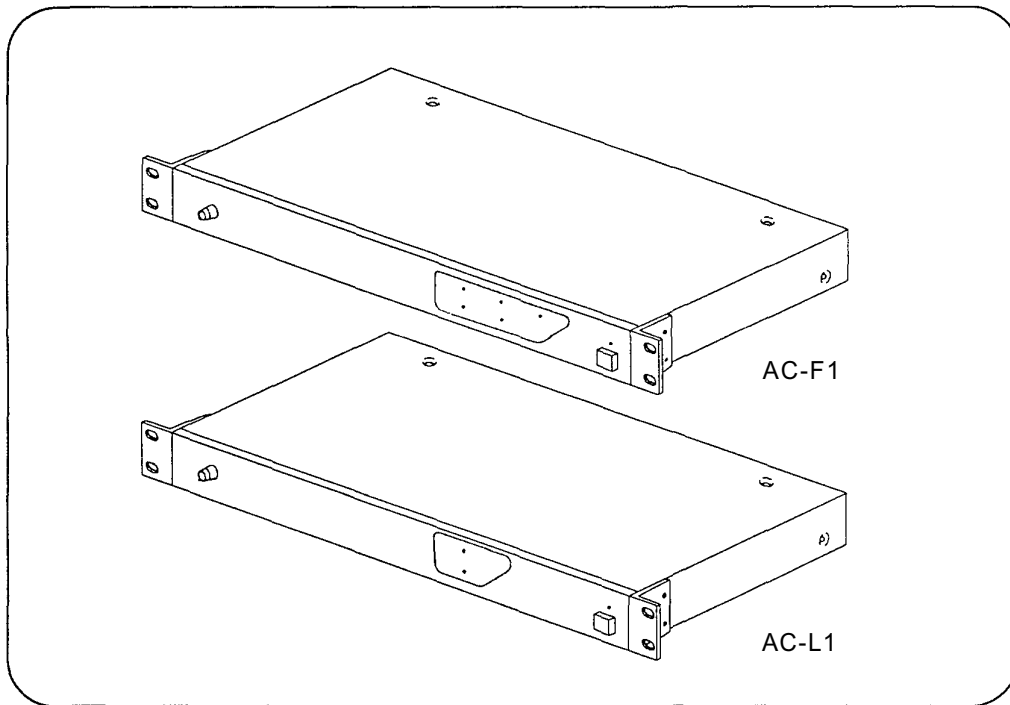

Operating Instructions

ELECTRONIC CONTROL UNIT

AC-F1
AC-L1



CONNECTION PRECAUTION

Be sure to provide a power amplifier, 300W (8Ω) or more output to use in connection with these units.

Use of less than 300W power amplifier will not maintain primary capabilities and will lead to failures of the connecting speakers.

These AC-F1/AC-L1 can exclusively be used for the SR-F1 speaker system and the SR-L1 super woofer system. Do not use other speakers than the SR-F1 and the SR-L1.

Please follow the instructions in this manual to obtain the optimum results from these units. We also recommend you to keep this manual handy for future reference.

TOA Corporation

■ Contents

User care	4
General description	4
Features	5
Panel facilities	
● AC- F1 [Front view]	6
[Rear view]	7
● AC- L1 [Front view]	8
[Rear view]	9
Connection	
● Basic block diagram	10
● Back wiring connection with external equipment (1)	10
● Back wiring connection with external equipment (2)	11
● SR-F1 single system	12
Installation	13
Block diagrams	14
Specifications	15
● Accessories	15
Appearance	16

■ User care

- Never disassemble unit and touch the inside or insert metallic stuff into the inside as this may lead to a breakage or shock hazard.
- When water enters, a breakage or shock hazard can be caused. To prevent an accident, immediately unplug the power cord from the wall AC outlet and contact your nearest TOA dealer.
- Wipe unit down with a soft cloth when cleaning the exterior of unit. Never use such volatile liquids as thinner and benzine because their use may discolor unit.
- Ensure to ground unit.

■ General description

The AC-F1 and the AC-L1 Electronic control units are designed for use with the SR-F1 speaker system and the SR-L1 super woofer system, for single channel full range speaker and super woofer.

These electronic control units provide the channel divider to divide respective frequency range between the speaker units, and can realize smooth phase characteristics in the speaker system, by according with the phase in crossover frequency while correcting time lag for the divided frequency range each other between the speaker units.

In high frequency range in combination with the compression driver and the constant directivity (CD) horn, the horn equalizer employs to provide smooth phase and amplitude characteristics.

To moderate the frequency response (3~4kHz) susceptible to saturation to listener's ears at the highest sound pressure, dynamic equalizer is provided to control such frequency response.

Limiter is provided to prevent the speaker units from over-driven and damage in respective frequency range and not to arise power amplifier clipping.

When suspending the SR-F1 to the ceiling, crossover select switch is provided to sharply cut off the crossover frequency between the super woofer and the woofer.

Quality sound is realized by use of selected electronic parts as OP amplifier, condensers etc.

■ Features

- Time lag between speaker units in the speaker system is corrected.
- Provided the frequency dividing network function.
- Accorded with phase at the crossover frequency.
- Limiter is provided to prevent the speaker units from over-driven and damage in each frequency range and not to arise power amplifier clipping.
- Dynamic equalizer is provided to correct general characteristics of the speaker system, and to control the frequency response (3~4kHz) susceptible to saturation to listener's ears.
- Crossover select switch is provided to control when the SR-F1 is suspended to the ceiling.
- Strictly selected parts and component parts are used for materializing quality sound.
- Can be mounted on 19" EIA standard rack, (one size)
- The AC-F1 and the AC-L1 are designed enabling to use with the SR-F1 and the SR-L1.
- Input and output are used the electronically balanced XLR type connector.
(Pin No.3 : HOT, No.2 : COLD and No.1 : GND)

■ Panel facilities

model AC-F1

[Front view]

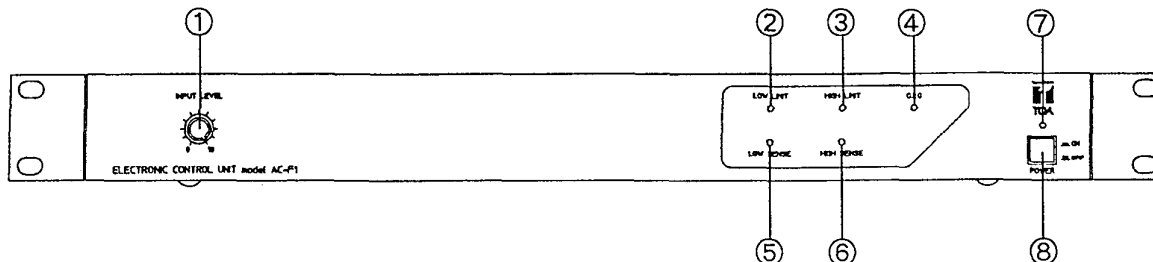

① Input level control (INPUT LEVEL)

Input level control adjusts the input level of AC-F1.

It is usually used to turn fully clockwise (Level 10), and adjusts at 26dB of each power amplifier gain for the super woofer, the woofer and the driver.

② Low limit indicator (LOW LIMIT)

Low limit indicator comes on when the low limiter circuit starts to employ with signal of low sense input terminal. In case the indicator very often flashes, adjust the input level until it occasionally flashes.

When adjusting by the input level control, the low level control of the AC-L1 should be set at same position as the input level control of the AC-F1.

③ High limit indicator (HIGH LIMIT)

High limit indicator comes on when the high limiter circuit starts to employ with signal of high sense input terminal. In case the indicator very often flashes, adjust the input level until it occasionally flashes.

When adjusting by the input level control, the low level control of the AC-L1 should be set at same position as the input level control of the AC-F1.

④ Dynamic equalizer indicator (D. EQ)

Dynamic equalizer indicator comes on when the dynamic equalizer circuit starts to employ with signal of high sense input terminal.

⑤ Low sense input indicator (LOW SENSE)

Low sense input indicator comes on when signal is input to the low sense input terminal.

⑥ High sense input indicator (HIGH SENSE)

High sense input indicator comes on when signal is input to the high sense input terminal.

⑦ Power indicator

Power indicator comes on when the power switch is ON.

⑧ Power switch (POWER)

Press this switch to turn power ON or press it again to turn power OFF.

[Rear view]

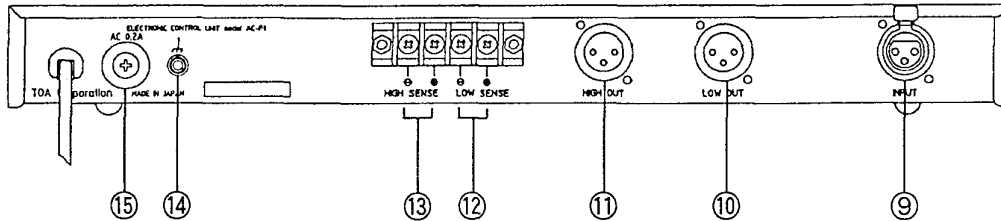

⑨ Input connector (INPUT)

Input connector for signal is used the electronically balanced XLR type connector.

⑩ Low output connector (LOW OUT)

Output connector to the power amplifier for low frequency range is used the electronically balanced XLR type connector.

⑪ High output connector (HIGH OUT)

Output connector to the power amplifier for high frequency range is used the electronically balanced XLR type connector.

⑫ Low sense input terminal (LOW SENSE)

Input terminal for inputting signal from the power amplifier output for low frequency range is used the electronically balanced screw terminal.

Connect to accord with polarities (\oplus , \ominus) between the power amplifier output terminal and the sense input terminal.

⑬ High sense input terminal (HIGH SENSE)

Input terminal for inputting signal from the power amplifier output for the high frequency range is used the electronically balanced screw terminal.

Connect to accord with polarities (\oplus , \ominus) between the power amplifier output terminal and the sense input terminal.

⑭ Earth terminal

Be sure to ground the unit.

⑮ Fuse

When the fuse blew, ensure to replace it with the same type fuse after confirming its causes and countermeasures. (Be sure unplug the power cord before replacing with a new fuse.)

Use of other fuses than the same type fuse will lead to failures of unit.

Fuse rating

220 - 240V version	250V	T80mA
120V version	250V	0.2A

model AC-L1

[Front view]

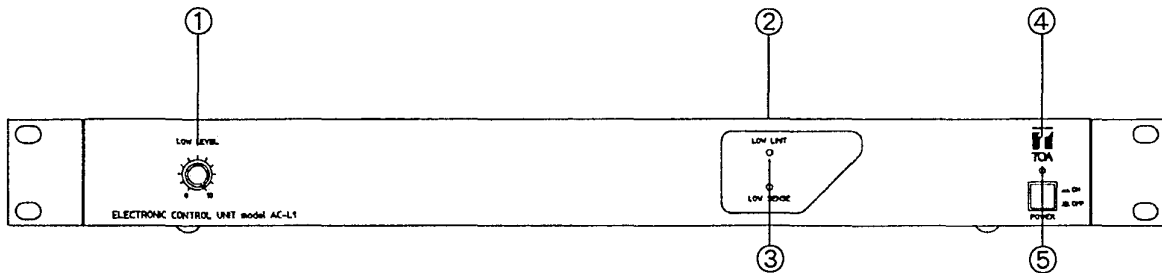

① Low level control (LOW LEVEL)

Low level control adjusts the low level of AC-L1.

It is usually used to turn fully clockwise (Level 10), and adjusts at 26dB of each power amplifier gain for the super woofer, the woofer and the driver. It can not adjust high output level.

② Low limit indicator (LOW LIMIT)

Low limit indicator comes on when the low limiter circuit starts to employ with signal of low sense input terminal. In case the indicator very often flashes, adjust the input level until it occasionally flashes.

When adjusting by the low level control, the input level control of the AC-F1 should be set at same position as the low level control of the AC-L1.

③ Low sense input indicator (LOW SENSE)

Low sense indicator comes on when signal is input to the low sense input terminal.

④ Power indicator

Power indicator comes on when the power switch is ON.

⑤ Power switch (POWER)

Press this switch to turn power ON or press it again to turn power OFF.

[Rear view]

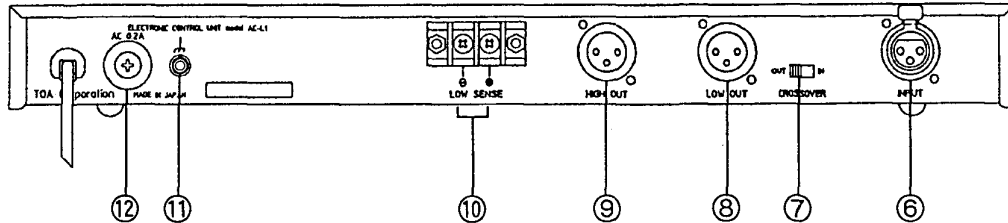

⑥ Input connector (INPUT)

Input connector for signal is used the electronically balanced XLR type connector.

⑦ Crossover select switch (CROSSOVER)

Crossover select switch can change the crossover filter to set the frequency range between the SR-L1 (super woofer system) and the SR-F1 (speaker system). Usually set the crossover select switch to OUT.

Set it to IN if the SR-F1 is suspended to the ceiling or if the distance between the SR-F1 and the SR-L1 is installed apart.

⑧ Low output connector (LOW OUT)

Output connector to the power amplifier for the super woofer is used the electronically balanced XLR type connector.

⑨ High output connector (HIGH OUT)

Output of this connector connects to the input of the AC-F1, and the connector is used the electronically balanced XLR type connector.

⑩ Low sense input terminal (LOW SENSE)

Low sense input terminal for inputting signal from the power amplifier output for the super woofer is used the electronically balanced screw terminal.

Connect to accord with polarities (⊕, ⊖) between the power amplifier output connector and the sense input terminal.

⑪ Earth terminal

Be sure to ground the unit.

⑫ Fuse

When the fuse blew, ensure to replace it with the same type fuse after confirming its causes and countermeasures. (Be sure unplug the power cord before replacing with a new fuse.)

Use of other fuses than the same type fuse will lead to failures of unit.

Fuse rating

220 - 240V version	250V	T80mA
120V version	250V	0.2A

■ Connection

● Basic block diagram

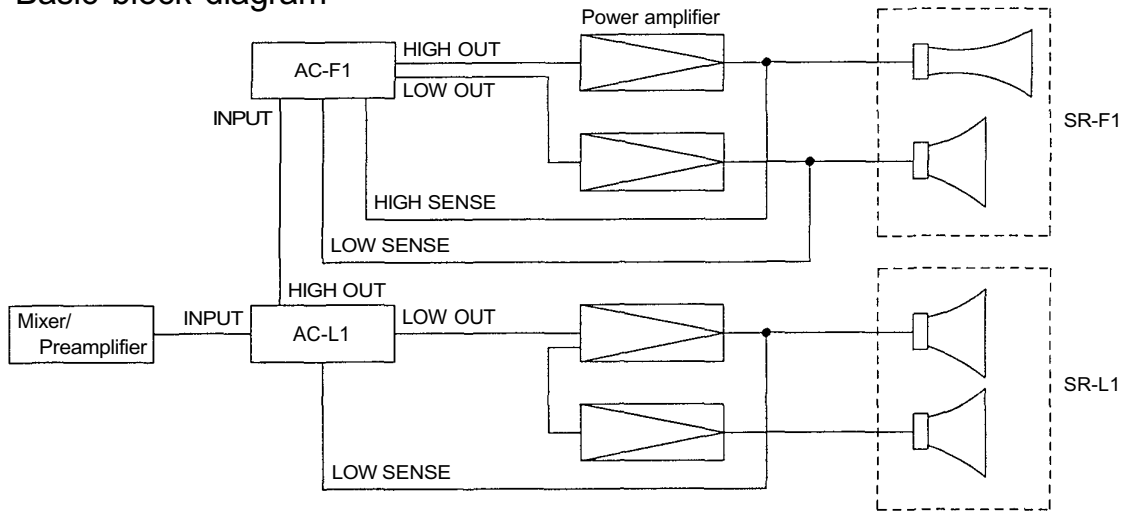

Connect a power amplifier, 300W(8Ω) or more output.

● Back wiring connection of with external equipment (1)

When one SR-F1 is mounted on the SR-L1

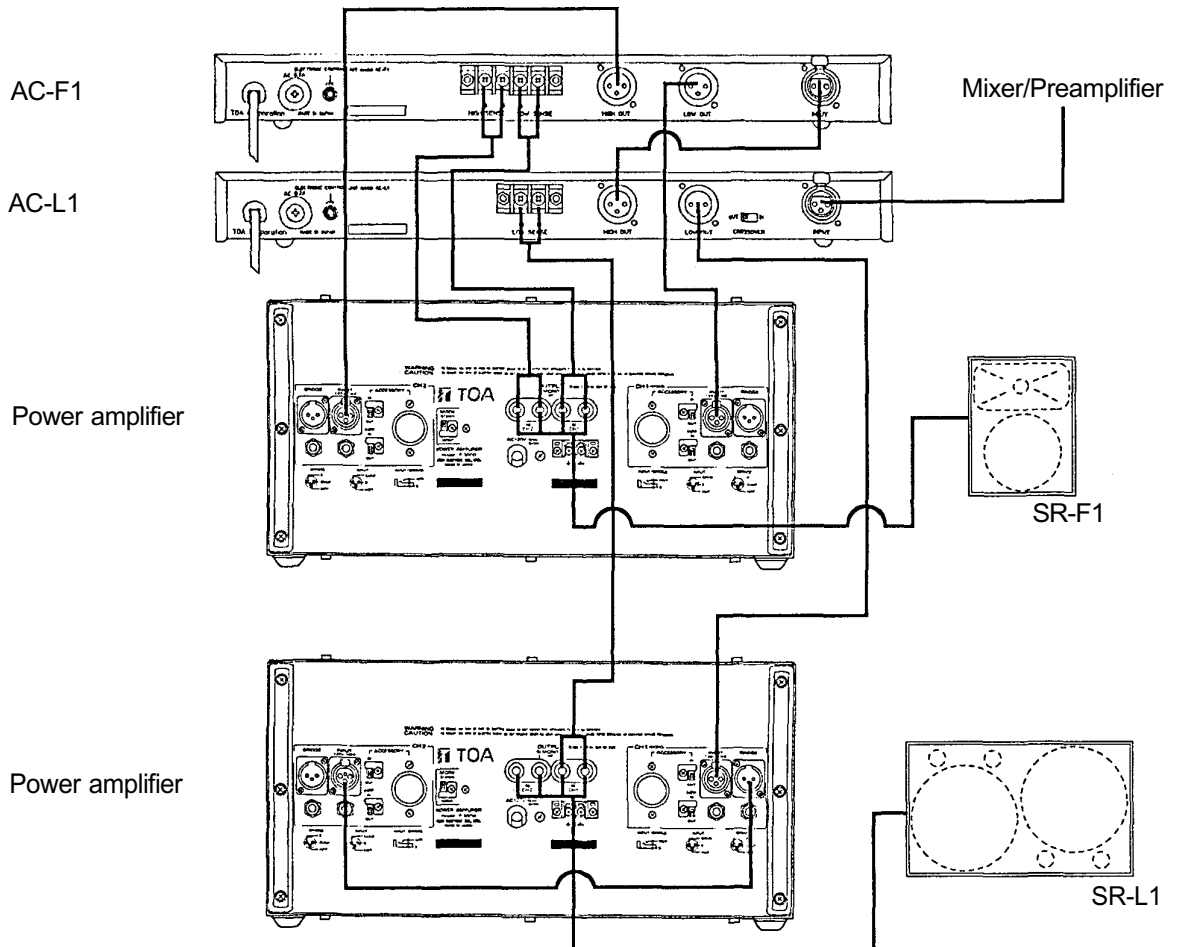

● Back wiring connection of with external equipment (2)

When two SR-F1 are mounted on the SR-L1

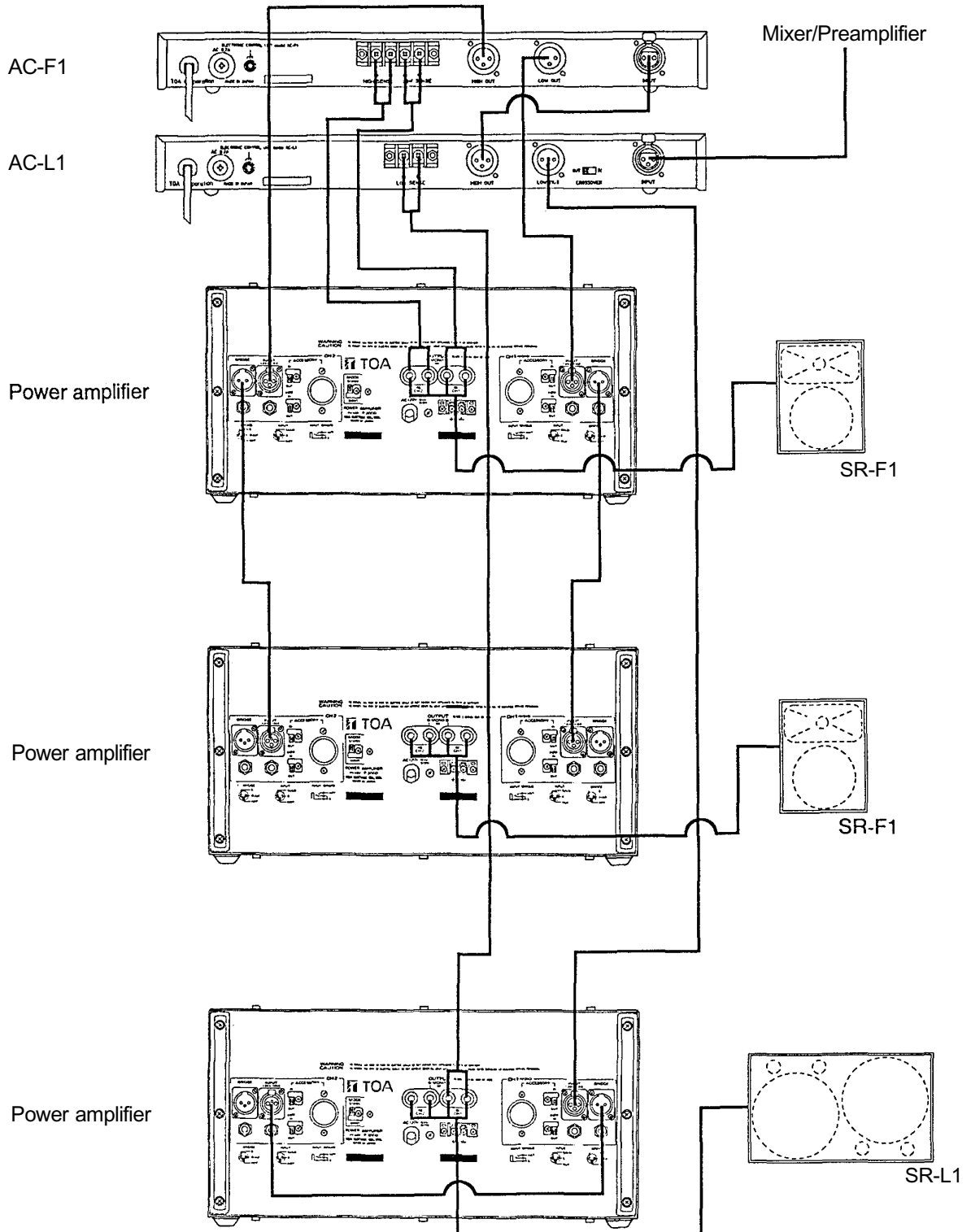

● SR-F1 single system

- Block diagram

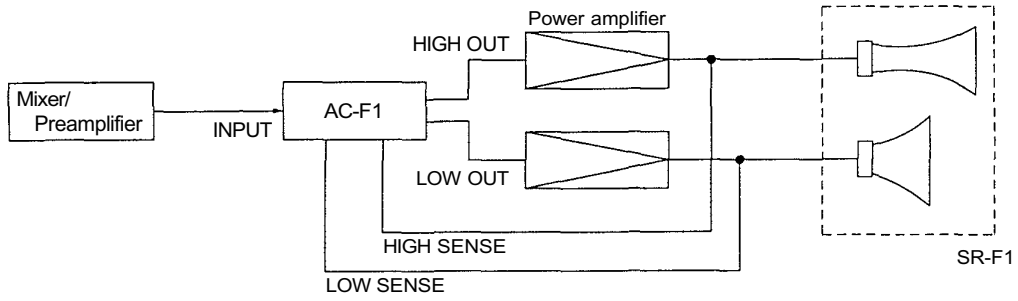

Connect a power amplifier, 300W (8Ω) or more output.

- Connection

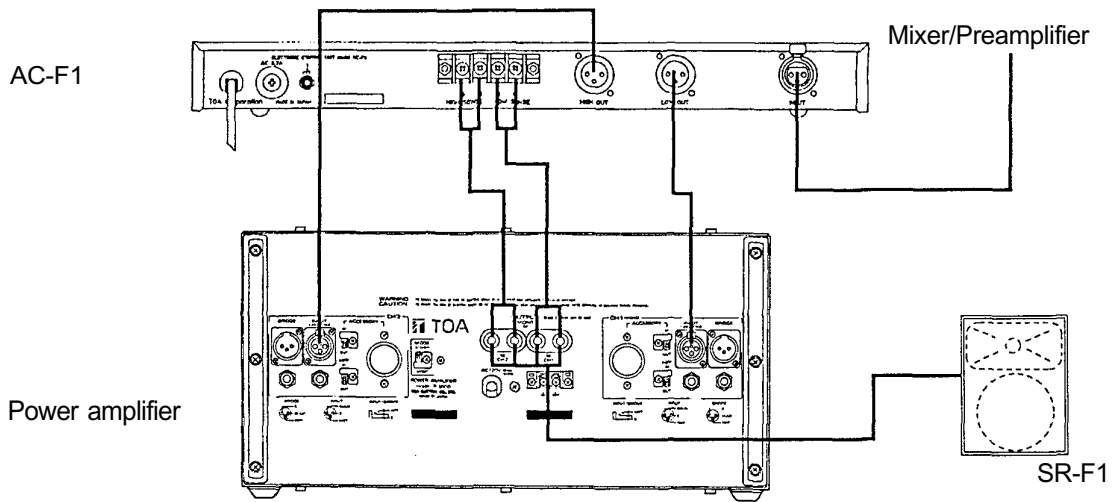

■ Installation

Mount the speakers arranging their front edges as shown in the figure.
For details, refer to "Operating Instructions of the speaker systems".

• When one SR-F1 is mounted on the SR-L1

• When two SR-F1 are mounted on the SR-L1

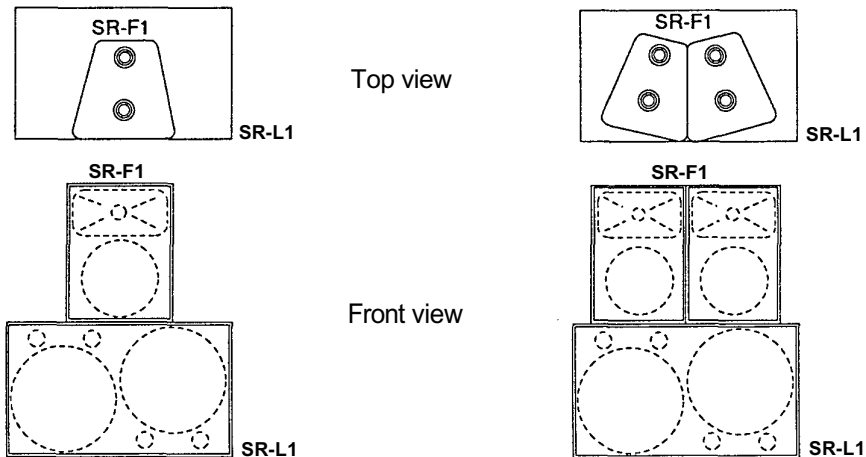

When the SR-F1 mounting on the SR-L1 is used, the crossover select switch of AC-L1 is turned to OUT. After setting the switch, confirm sound characteristics in actual operation.

In some cases, better characteristics are obtainable by turning the switch to IN according to the environmental conditions installed the speakers.

Crossover select switch is turned to IN when the SR-F1 is suspended to the ceiling.

Note

Refer to "Operating instructions of the SR-F1/SR-L1" on connection diagrams with the speakers and power amplifiers. Unless all polarities are accorded, these speaker systems are not employed.

Block diagram

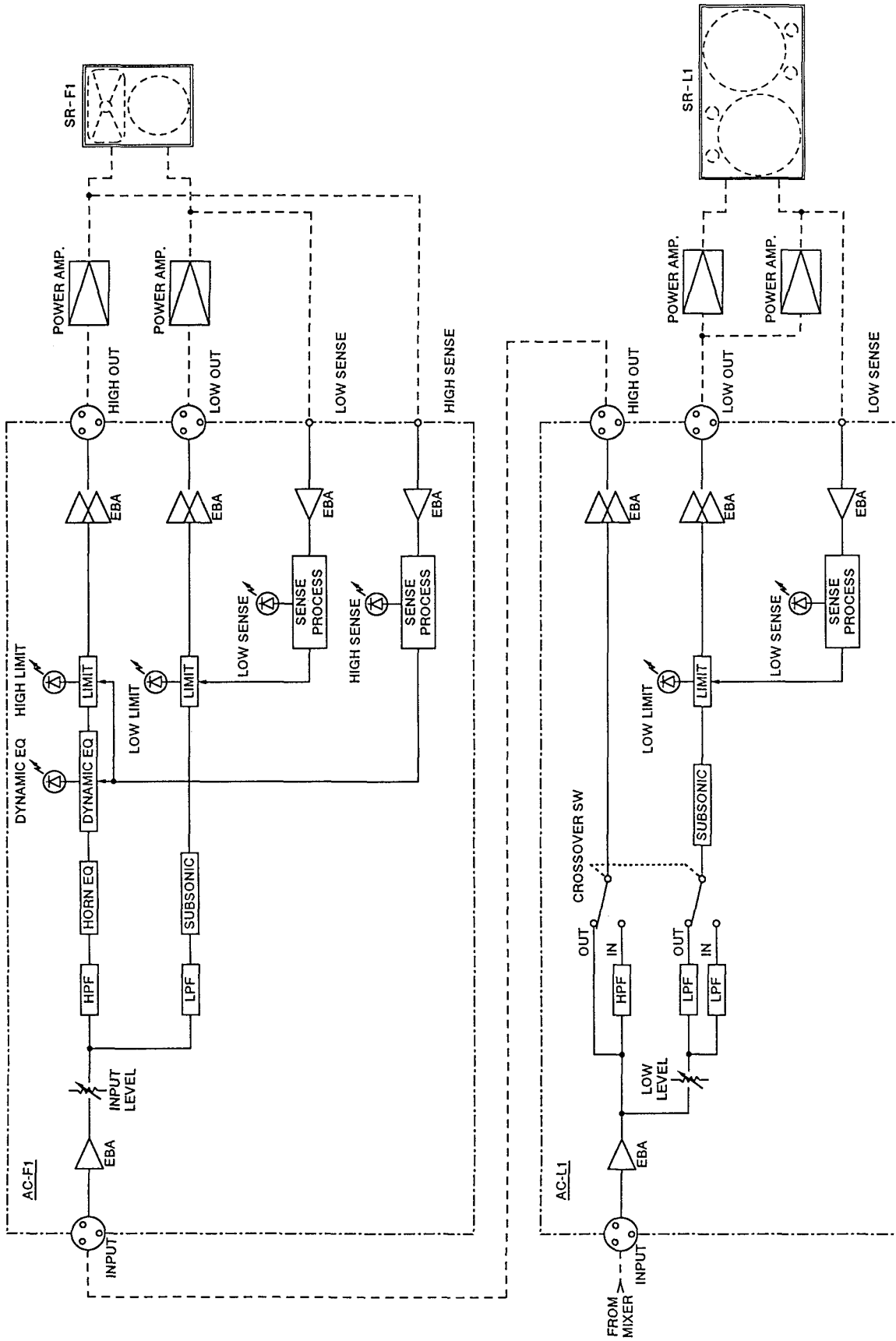

Specifications

Model	AC-F1	AC-L1
Input	Electronically balanced(Cannon XLR-3-31 or equivalent)	
Input impedance	20k Ω (Balanced) 10k Ω (Unbalanced)	
Rated input level	+4dB* (Pin No.3 : HOT, No.2 : COLD and No.1 : GND)	
Max. input level	+26dB*	
Sense input	Electronically balanced (4P screw terminal)	Electronically balanced (2P screw terminal)
Sense input impedance	10k Ω	
Output	Electronically balanced (Cannon XLR-3-32 or equivalent)	
Output impedance	600 Ω (Balanced)	
Rated output level	+4dB*	
Max. output level	+26dB*(Balanced) +20dB*(Unbalanced)	
Crossover frequency	1kHz	125Hz
Distortion	Less than 0.05%(+4dB* 1kHz)	
Hum & Noise	Less than -90dB*(20Hz~20kHz)	
Indicators	- Power : green LED -Sense input : green LED (LOW SENSE, HIGH SENSE) - Limit : red LED (LOW LIMIT, HIGH LIMIT) - Dynamic Equalizer: green LED (D.EQ)	- Power : green LED -Sense input : green LED (LOW SENSE) - Limit : red LED (LOW LIMIT)
Front panel operation	Input level control Power switch	Low level control Power switch
Rear panel operation	—	Crossover select switch
Power requirement	AC Mains, 50Hz/60Hz	
Power consumption	12W 120V version 16W 220V -240V version	10W 120V version 12W 220V -240V version
Weight	3.7kg(8.16lb.)	

* Specifications are subject to change without notice.

※ OdB=0.775Vrms

● Accessories

Fuse	1
Warranty card (for USA and Canada only)	1
Operating instructions	1

Appearance

AC-F1

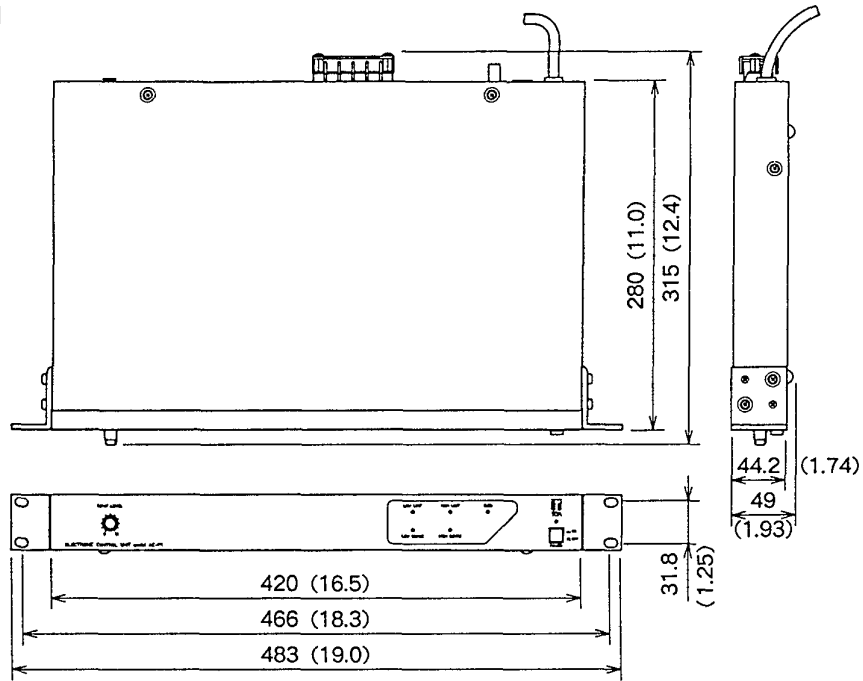

AC-L1

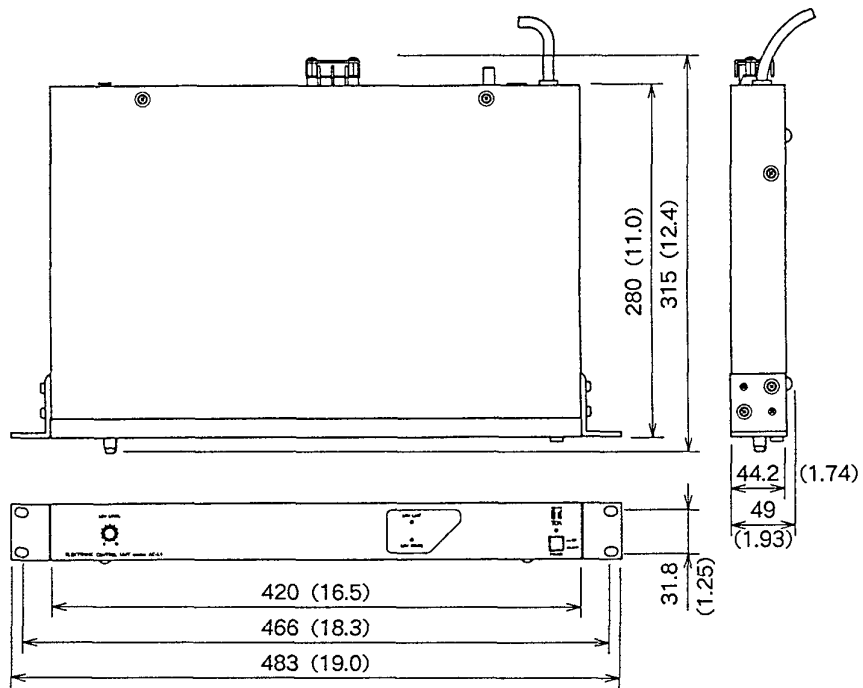

mm(in.)



TOA Corporation
KOBÉ, JAPAN

133-02-996-30