

DESCRIPTION

The Q-RS180BZ is a substation of N-8000 network intercom system designed for Rescue Assistance applications and ADA compliance. It has Emergency and Braille signage, a red mushroom call button, water-resistant buzzer, LED indicator and control output. This substation can be connected with N-8000RS or N-8010RS with a 2-core shielded cable.

SPECIFICATIONS

Rated Input	1 W
Rated Impedance	625 Ω (1 W/25 V)
Internal Speaker	4 cm cone-type
Buzzer	Water proof type
Control Output	Open collector, Withstand voltage: 30 VDC, Control current: 30 mA (The open collector output and the buzzer are kept turned on till the conversation is finished after the call button was pressed.)
Wiring	Two-core shielded cable
Transmission Range	0.5 km (546 yd)/∅0.5 mm (AWG24) 0.8 km (874 yd)/∅0.65 mm (AWG22) 1.3 km (1421 yd)/∅0.9 mm (AWG19)
Operating Temperature	-10 °C to +50 °C (Temperature range not to freeze the speaker and switch)
Finish	Panel: Stainless steel, hairline Braille: "EMERGENCY PUSH FOR HELP" "FLASHING: CALL PLACED STEADY: CALL ANSWERED" Call button: Metal (RED Mushroom) Printed circuit board: Weather-resistant coating
Dimensions	115 (W) × 162 (H) × 66.8 (D) mm (4.53" × 6.38" × 2.63")
Weight	700 g (1.54 lb)
Accessory	Box mounting screw (No.6-32UNC × 8) ...4, Box mounting screw (M4 × 25) ...4
Applicable Box	3-gang electrical box: YC-150 or YS-13A (option)

APPEARANCE

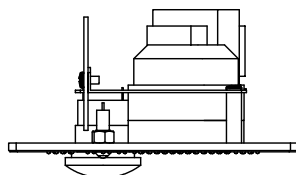

Top View

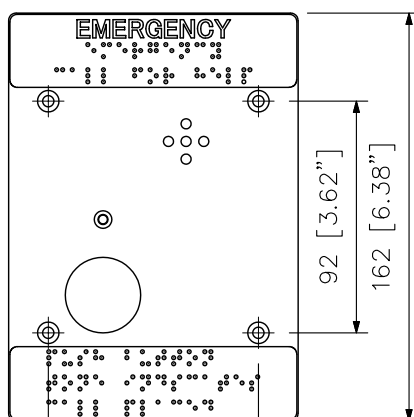

Front View

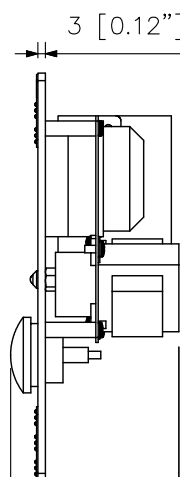

Side View

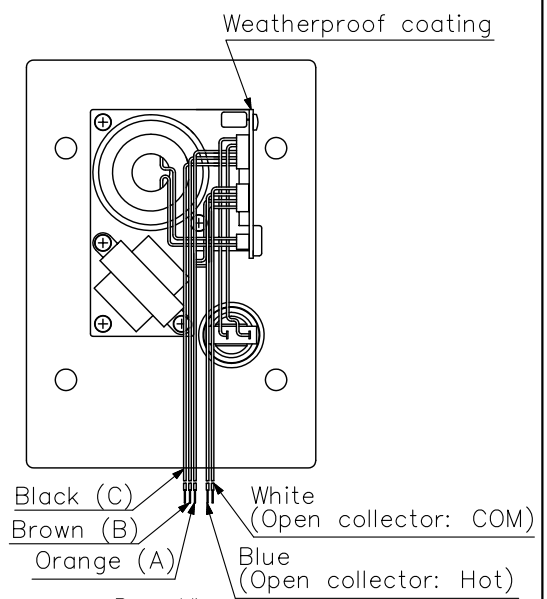

Rear View

UNIT:mm SCALE:1/3