

ACTIVE LINE ARRAY SPEAKER SYSTEMS

SR-D8-M, SR-D8-S

Optional products	
WALL MOUNTING ADAPTER	SR-D8CS
WALL MOUNTING ADAPTER	SR-D8CL
EXTENSION PLATE	SR-D8EP
WALL MOUNTING BRACKET	SR-D8WB
HOISTING BRACKET	SR-D8HB
FIXING BAR	SR-D8FB

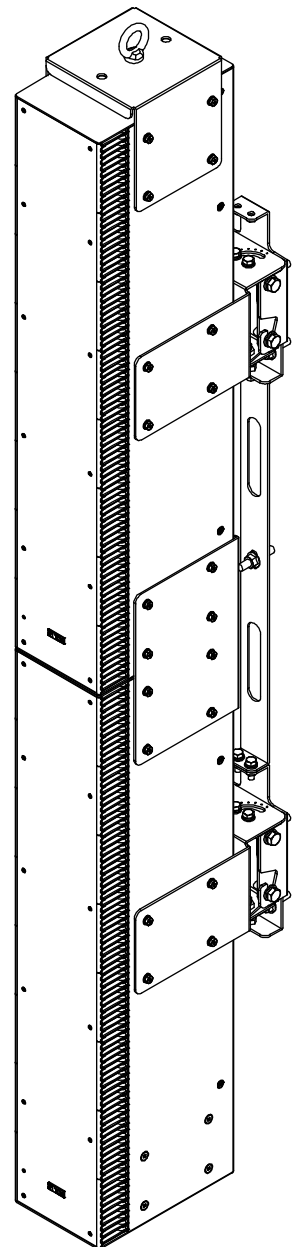

Thank you for purchasing TOA's Active Line Array Speaker System.
Please carefully follow the instructions in this manual to ensure long, trouble-free use of your equipment.

TABLE OF CONTENTS

1. IMPORTANT SAFETY INSTRUCTIONS	3
2. SAFETY PRECAUTIONS	4
3. GENERAL DESCRIPTION	6
4. FEATURES	6
5. INSTALLATION PRECAUTIONS	7
6. HANDLING PRECAUTIONS	7
7. NOMENCLATURE AND FUNCTIONS	8
8. BRACKETS	11
9. COMMUNICATIONS BETWEEN PC AND SPEAKERS	12
10. CONNECTIONS	13
10.1. Connection Example 1 (CobraNet Connection)	13
10.2. Connection Example 2 (CobraNet Connection, 4-Unit Configuration)	14
10.3. Connection Example 3 (Analog Line Connection)	15
10.4. Connection Example 4 (Maximum System)	16
10.5. Removable Terminal Plug Connection	18
10.6. Fixing Power Supply Cord	19
10.7. System Expansion Using CobraNet Connection	20
11. INSTALLATION	24
11.1. Installing a Single SR-D8-M Unit	24
11.2. Installing SR-D8-M and SR-D8-S(s) in multi-unit configuration	26
11.3. Angle Adjustment	31
12. DIMENSIONAL DIAGRAMS	33
12.1. SR-D8-M, SR-D8-S Active Line Array Speaker Systems	33
12.2. Brackets	33
13. SPECIFICATIONS	35
13.1. SR-D8-M, SR-D8-S Active Line Array Speaker Systems	35
13.2. Brackets	36

1. IMPORTANT SAFETY INSTRUCTIONS

- Read these instructions.
- Keep these instructions.
- Heed all warnings.
- Follow all instructions.
- Do not use this apparatus near water.
- Clean only with dry cloth.
- Do not block any ventilation openings. Install in accordance with the manufacturer's instructions.
- Do not install near any heat sources such as radiators, heat registers, stoves, or other apparatus (including amplifiers) that produce heat.
- Do not defeat the safety purpose of the polarized or grounding-type plug. A polarized plug has two blades with one wider than the other. A grounding type plug has two blades and a third grounding prong. The wide blade or the third prong are provided for your safety. If the provided plug does not fit into your outlet, consult an electrician for replacement of the obsolete outlet.
- Protect the power cord from being walked on or pinched particularly at plugs, convenience receptacles, and the point where they exit from the apparatus.
- Only use attachments/accessories specified by the manufacturer.
- Unplug this apparatus during lightning storms or when unused for long periods of time.
- Refer all servicing to qualified service personnel. Servicing is required when the apparatus has been damaged in any way, such as power-supply cord or plug is damaged, liquid has been spilled or objects have fallen into the apparatus, the apparatus has been exposed to rain or moisture, does not operate normally, or has been dropped.

2. SAFETY PRECAUTIONS

- Before installation or use, be sure to carefully read all the instructions in this section for correct and safe operation.
- Be sure to follow all the precautionary instructions in this section, which contain important warnings and/or cautions regarding safety.
- After reading, keep this manual handy for future reference.

Safety Symbol and Message Conventions

Safety symbols and messages described below are used in this manual to prevent bodily injury and property damage which could result from mishandling. Before operating your product, read this manual first and understand the safety symbols and messages so you are thoroughly aware of the potential safety hazards.



WARNING

Indicates a potentially hazardous situation which, if mishandled, could result in death or serious personal injury.



CAUTION

Indicates a potentially hazardous situation which, if mishandled, could result in moderate or minor personal injury, and/or property damage.



WARNING

When Installing the Unit

- This apparatus must be securely attached to the wall per installation instructions. Tipping, shaking, or rocking the machine may cause injury/death.
- Do not expose the unit to rain or an environment where it may be splashed by water or other liquids, as doing so may result in fire or electric shock.
- Use the unit only with the voltage specified on the unit. Using a voltage higher than that which is specified may result in fire or electric shock.
- Do not cut, kink, otherwise damage nor modify the power supply cord. In addition, avoid using the power cord in close proximity to heaters, and never place heavy objects -- including the unit itself -- on the power cord, as doing so may result in fire or electric shock.
- The apparatus shall be connected to a mains socket outlet with a protective earthing connection.
- The socket-outlet shall be installed near the equipment and the plug (disconnecting device) shall be easily accessible.
- Refer all hoisting work to the dealer from whom the speaker was purchased. Hoisting work requires extensive technical knowledge and experience. The speaker may fall off if incorrectly installed, resulting in possible personal injury.
- Hoisting work Precautions
Be sure to follow the instructions below. Otherwise, the hoisting wires or belts may be off or snap and the speaker may fall off, causing personal injury.
 - Use the SR-D8HB Hoisting Bracket for hoisting the speaker.
 - Check to confirm that the hoisting wires and belts are strong enough to withstand the speaker load.
 - The hoisting wires and belts must be securely connected to the speaker.
- All parts and components (such as enclosures, metal pieces, and bolts) must be free from any deformation, crack, and corrosion.
- Install the unit only in a location that can structurally support the weight of the unit and the mounting bracket. Doing otherwise may result in the unit falling down and causing personal injury and/or property damage.
- Do not use this speaker in a flying installation. Never use the eyebolt mounted on top of the speaker stack (multi-unit line array) for the purpose of permanent installation. Be sure to use the eyebolt only for hoisting work. Failure to observe the instructions may result in the unit falling down, and causing personal injury.
- Install the unit on the wall tilting within 30°. Doing otherwise may result in the unit falling down, and causing personal injury.

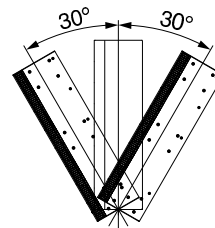

the unit. Extreme force is applied to the unit and the unit could fall off, possibly resulting in personal injuries.

- Attach the safety wire, strong enough to withstand heavy load, to the unit. If not attached, the unit could fall off, resulting in personal injury.
- Use nuts and bolts that are appropriate for the wall's structure and composition. Failure to do so may cause the speaker to fall, resulting in material damage and possible personal injury.
- Tighten each nut and bolt securely. Ensure that the mounting bracket has no loose joints after installation to prevent accidents that could result in personal injury.
- Use the specified mounting bracket in combination. Doing otherwise may cause the unit or component to fall off, resulting in personal injury.
- Do not mount the unit in locations exposed to constant vibration. The mounting bracket can be damaged by excessive vibration, potentially causing the unit to fall, which could result in personal injury.

When the Unit is in Use

- Do not use anti-rust lubricant. If it contacts resin or rubber parts, they could deteriorate and cause the unit to fall, possibly resulting in personal injury.
- Should the following irregularity be found during use, immediately unplug the power supply cord and contact your nearest TOA dealer. Make no further attempt to operate the unit in this condition as this may cause fire or electric shock.
 - If you detect smoke or a strange smell coming from the unit.
 - If water or any metallic object gets into the unit
 - If the unit falls, or the unit case breaks
 - If the power supply cord is damaged (exposure of the core, disconnection, etc.)
 - If it is malfunctioning (no tone sounds.)
- To prevent a fire or electric shock, never open nor remove the unit case as there are high voltage components inside the unit. Refer all servicing to qualified service personnel.
- Do not place cups, bowls, or other containers of liquid or metallic objects on top of the unit. If they accidentally spill into the unit, this may cause a fire or electric shock.
- Do not insert nor drop metallic objects or flammable materials into the ventilation slots in the unit's rear and bottom, as this may result in fire or electric shock.
- Do not touch the power supply plug during thunder and lightning, as this may result in electric shock.



When Installing the Unit

- Never plug in nor remove the power supply plug

with wet hands, as doing so may cause electric shock.

- When unplugging the power supply cord, be sure to grasp the power supply plug; never pull on the cord itself. Operating the unit with a damaged power supply cord may cause a fire or electric shock.
- When moving the unit, be sure to remove its power supply cord from the wall outlet. Moving the unit with the power cord connected to the outlet may cause damage to the power cord, resulting in fire or electric shock.
- Do not block the ventilation slots in the unit's rear and bottom. Doing so may cause heat to build up inside the unit and result in fire. Also, periodically clean the ventilation slots of dust.
- Avoid installing the unit in humid or dusty locations, in locations exposed to the direct sunlight, near the heaters, or in locations generating sooty smoke or steam as doing otherwise may result in fire or electric shock.
- When unpacking or moving the unit, be sure to handle it with two or more persons. Falling or dropping the unit may cause personal injury and/or property damage.
- Avoid touching the unit's sharp metal edge to prevent injury.
- To avoid electric shocks, be sure to unplug the power supply cord when making cable connections.

When the Unit is in Use

- Do not place heavy objects on the unit as this may cause it to fall or break which may result in personal injury and/or property damage. In addition, the object itself may fall off and cause injury and/or damage.
- Do not operate the unit for an extended period of time with the sound distorting. Doing so may cause the connected speakers to heat, resulting in a fire.
- Contact your TOA dealer as to the cleaning. If dust is allowed to accumulate in the unit over a long period of time, a fire or damage to the unit may result.
- If dust accumulates on the power supply plug or in the wall AC outlet, a fire may result. Clean it periodically. In addition, insert the plug in the wall outlet securely.
- Unplug the power supply plug from the AC outlet for safety purposes when cleaning or leaving the unit unused for 10 days or more. Doing otherwise may cause a fire or electric shock.
- Do not stand or sit on, nor hang down from the unit as this may cause it to fall down or drop, resulting in personal injury and/or property damage.
- Have the unit checked periodically by the shop from where it was purchased. Failure to do so may result in corrosion or damage to the unit or its mounting bracket that could cause the unit to fall, possibly causing personal injury.

3. GENERAL DESCRIPTION

The TOA SR-D8-M and SR-D8-S are all-in-one Active Line Array Speaker Systems, each featuring a CobraNet digital audio input (SR-D8-M only), digital signal processor, digital power amplifier, and speakers configured in a line array. Precise control of the speaker's vertical directivity and acoustic beamwidth makes it possible to create fully optimized sound spaces in a wide range of locations.

All function settings can be controlled from a remote PC using the supplied SR-D8 PC Software. Equipped with a primary audio input, the SR-D8-M transmits the audio signal to the secondary SR-D8-S via the SR-D8-M's dedicated local link. The local link allows up to 3 SR-D8-S speaker units to be connected in series to one SR-D8-M, permitting a line array of up to 4 connected speakers (hereinafter, a line array speaker system consisting of one or more speakers is referred to as "stack") to be configured. In a complete system, up to 4 stacks can be controlled, making it possible to build systems consisting of up to 16 speakers.

4. FEATURES

- Variable beam line array speaker unit equipped with 8 10 cm low-frequency woofers, 24 small high-frequency tweeters and an 8-channel 30 W (4 Ω output) digital power amplifier.
- Close vertical arrangement of the sound source speaker units creates a continuously linear sound source for a uniform sound field with less distance attenuation.
- A built-in signal processor controls the number of beams (a maximum of 2 beams per stack), beam angle (vertical directional angle) and beamwidth.
- Since the vertical coverage area can be set and the sound directed only to required areas, sound radiation to unnecessary areas is minimized to significantly reduce reverberation and reflection.
- Optimal sound fields can be created even in locations that restrict optimal speaker mounting angle, position and height.
- With two beams of output, a wide coverage area can be set to extend across long distances. Configuring a multi-unit array makes more precise settings possible.
- A sound level distribution simulation function allows coverage areas to be set while visually monitoring them.
- LAN connection permits PC controls using the supplied SR-D8 PC Software.
- The SR-D8 system's maximum configuration is 4 stacks (1 stack = 1 SR-D8-M unit + 3 SR-D8-S units), and up to 16 speakers can be controlled in synchronization.
- CobraNet ensures high-quality sound transmission.

Note: CobraNet is a trademark of Cirrus Logic Inc. .

5. INSTALLATION PRECAUTIONS

To avoid equipment failures, do not install the speaker in locations exposed to high temperatures or high humidity, such as indoor swimming pools.

6. HANDLING PRECAUTIONS

- The supplied power supply cord is designed for exclusive use with this unit. Never use it with other equipment.
- Install the unit in locations where the temperature is between 0 and +40 °C (32 and 104°F) and the moisture is less than 90% (no dew condensation must be formed).
- The units are precision audio components. To prevent failure, avoid locations where the unit may be exposed to strong shocks or vibrations.
- To clean, be sure to first remove the power cord from the unit, then wipe with a dry cloth. When the unit gets very dirty, use a cloth damped in a neutral cleanser. Never use benzene, thinner, alcohol, or chemically-treated cleaning cloth because such volatile liquids could deform or discolor the unit.

7. NOMENCLATURE AND FUNCTIONS

• SR-D8-M

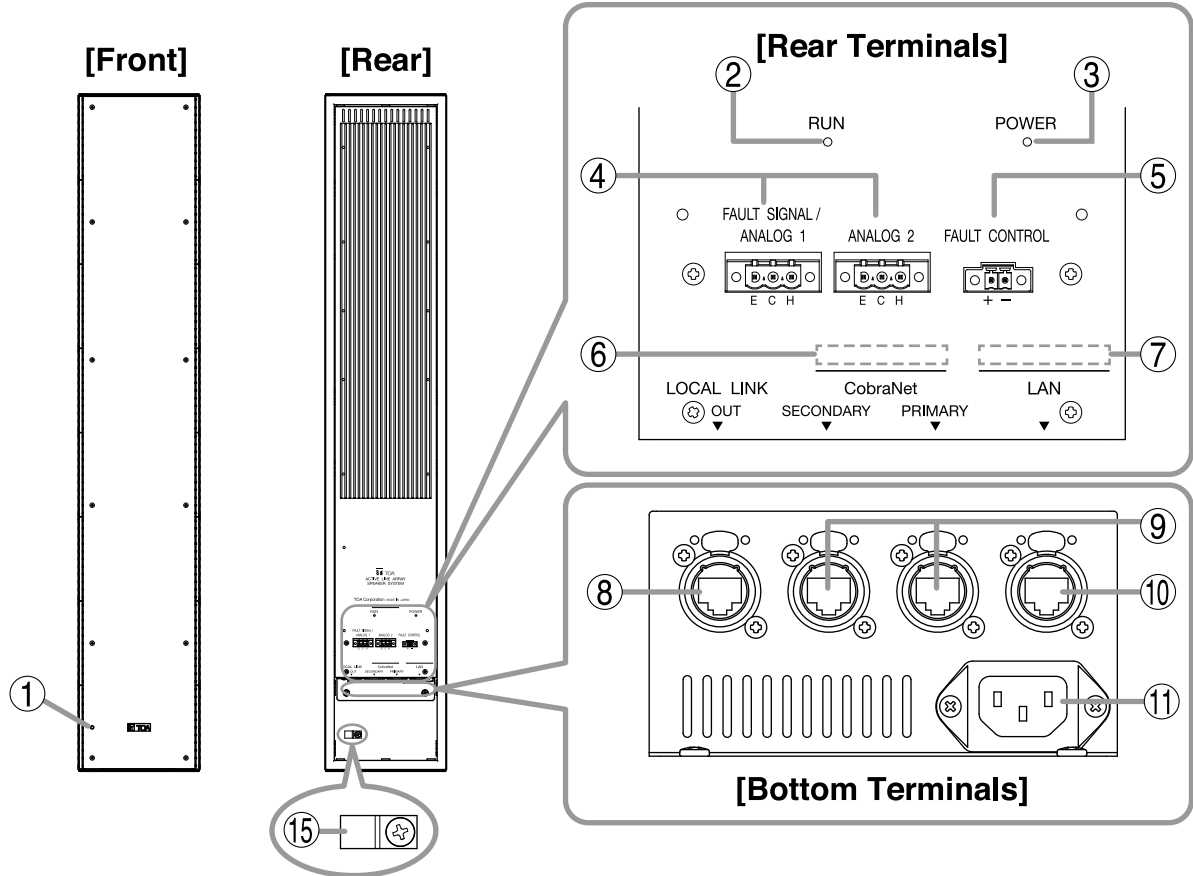

• SR-D8-S

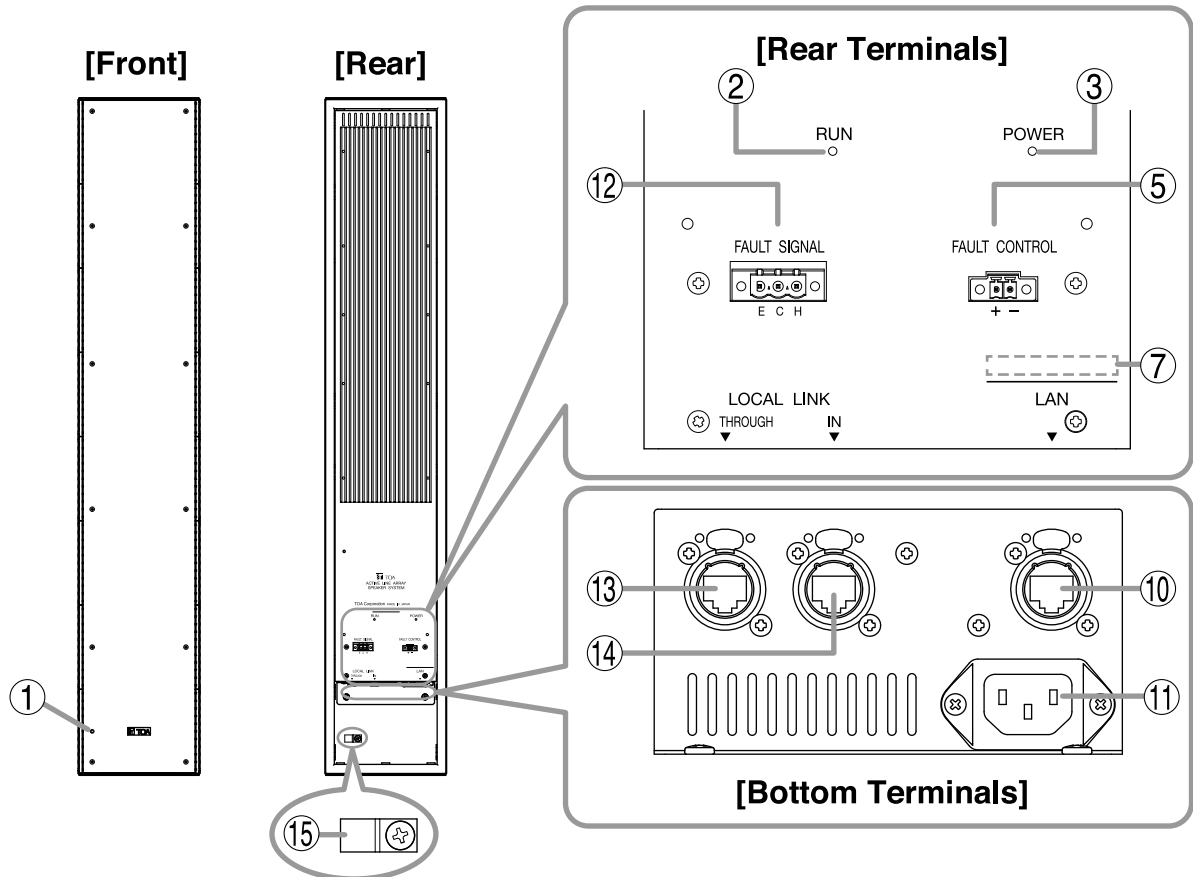

1. Status indicator (green)

Lights when the speaker is placed in fault state*1. This indicator may light arbitrarily during PC communication using the SR-D8 PC Software.

*1 The state in which audio signal can be directly input from the Analog 1 input terminal (4) to a digital amplifier without passing through the speaker's internal CPU by shorting the fault contact input terminals (5).

2. RUN indicator [RUN] (green)

Flashing: Correct operation of the unit.
Lit or Unlit: Abnormal operation of the unit.

3. Power indicator [POWER] (blue)

Lights when the power is switched ON.

4. Analog input terminals [FAULT SIGNAL/ANALOG 1, ANALOG 2]

Removable terminal block (3P) with electronically-balanced inputs.

(H: Hot, C: Cold, E: Ground.)

The ANALOG 1 input terminal can be used to directly input audio signal to the digital power amplifier, bypassing the unit's built-in CPU, when the Fault contact input terminal (5) is shorted.

Note

Up to 4 units' terminals can be connected in parallel.

5. Fault contact input terminal [FAULT CONTROL]

Used when audio output is interrupted due to failures in the built-in digital signal processor (DSP) or other circuit.

Shorting between the terminals of removable terminal blocks (2P) allows audio signals to be directly input to the built-in digital power amplifier from the ANALOG 1 input terminal (4), bypassing the unit's built-in DSP.

Therefore, the directivity control (variable beam function) cannot be performed through the DSP.

Notes

- As this terminal is a no-voltage contact input, never apply any voltage to it.
- Up to 4 units' terminals can be connected in parallel.

6. MAC address (CobraNet)

MAC address for CobraNet.

7. MAC address (CONTROL)

MAC address for the LAN.

8. Local link output terminal [LOCAL LINK OUT]

Outputs signals from SR-D8-M to SR-D8-S's Local link input terminal (14) when interconnecting SR-D8-M and SR-D8-S units in multi-unit configuration.

Use RJ45 connector.

etherCON*2 connector can also be used. (See Tip on p. 10.)

[LED]

No functions assigned ACTIVE indicator (always unlit)

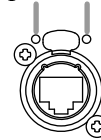

• ACTIVE indicator (orange)

Lit	Connection to SR-D8-S possible.
Unlit	Failure status

9. CobraNet terminals [CobraNet, PRIMARY, SECONDARY]

Used for CobraNet connection.

Connect the D-2008SP Digital Mixing Processor or other commercially available CobraNet equipment to these terminals via a switching hub. Connect the PRIMARY and SECONDARY terminals to a single switching hub or 2 cascade-connected hubs. Use RJ45 connector.

etherCON*2 connector can also be used. (See Tip on p. 10.)

Note

Be sure to connect both PRIMARY and SECONDARY terminals.

[LED]

SECONDARY operation/conductor Indicator

SECONDARY LINK/ACT indicator

PRIMARY LINK/ACT indicator

PRIMARY operation/conductor indicator

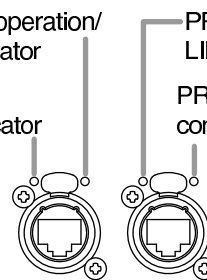

• PRIMARY operation/conductor indicator (orange)

• SECONDARY operation/conductor indicator (orange)

Flashing or lit	CobraNet operation Flashing: Conductor Lit: Performer Note Either PRIMARY or SECONDARY LED flashes or lights.
Unlit	No functions in operation Note PRIMARY and SECONDARY LEDs do not go out simultaneously.

• PRIMARY LINK/ACT indicator (green)

• SECONDARY LINK/ACT indicator (green)

Flashing or lit	Linkage to a switching hub or data transmission/receipt
Unlit	Unconnected

*2 etherCON is a trademark of Neutrik Co., Ltd.

10. LAN connection terminal [LAN]

For PC communication using the SR-D8 PC Software.

Connects to a 100BASE-TX-compatible network. Connect this terminal to a PC via a switching hub. Use RJ45 connector.

etherCON* connector can also be used. (See Tip below.)

Note

Do not connect the LAN terminal directly to the PC.

[LED]

LINK indicator FULL indicator

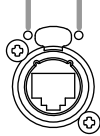

• FULL indicator (orange)

Lit	Communicating with a switching hub
Unlit	Undetected

• LINK indicator (green)

Lit	Linkage to a switching hub
Unlit	Undetected

11. AC inlet

Insert supplied power cord (2 m or 6.56 ft) into this socket.

12. Analog input terminal [FAULT SIGNAL]

Removable terminal block (3P) with electronically-balanced input.

(H: Hot, C: Cold, E: Ground)

This terminal is used for direct audio signal input to the digital power amplifier, bypassing the unit's built-in CPU, when the Fault Contact input terminal (5) is shorted.

Note

Up to 4 units' terminals can be connected in parallel.

13. Local link through terminal

[LOCAL LINK THROUGH]

Outputs signals from SR-D8-M to SR-D8-S's Local link input terminal (14) when interconnecting SR-D8-M and SR-D8-S units in 3-unit or 4-unit configuration.

Use RJ45 connector.

etherCON* connector can also be used. (See Tip below.)

[LED]

No functions assigned (always unlit) ACTIVE indicator



• ACTIVE indicator (orange)

Lit	Connection to SR-D8-S possible.
Unlit	Failure status

14. Local link input terminal [LOCAL LINK IN]

Accepts signals from SR-D8-M's Local link output terminal (8) or SR-D8-S's Local link through terminal (13) when interconnecting SR-D8-M and SR-D8-S units in multi-unit configuration.

Use RJ45 connector.

etherCON* connector can also be used. (See Tip below.)

[LED]

No functions assigned (always unlit) LINK indicator

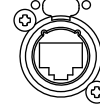

• LINK indicator (orange)

Lit	Connection to SR-D8-M complete.
Unlit	Undetected

15. Cord clamp

Fixes the power cord.

Tips

- Use STP Category 5 Standard straight through cable with RJ45 connectors.
- For etherCON* connectors, use Neutrik NE8MC or NEC8MC-B.

* etherCON is a trademark of Neutrik Co., Ltd.

8. BRACKETS

• SR-D8CS Wall Mounting Adapter

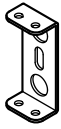

Hex bolt M8x25 (with spring and plain washers) ... 4

• SR-D8CL Wall Mounting Adapter



Hex bolt M8x25 (with spring and plain washers) ... 4

• SR-D8EP Extension Plate

L bracket

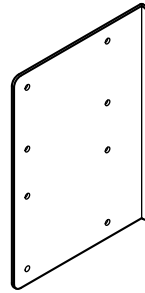

R bracket

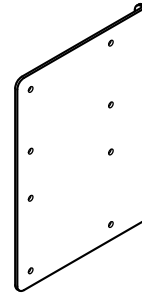

Hex bolt M6x20 (with spring and plain washers, paint) ... 16

• SR-D8WB Wall Mounting Bracket

Wall bracket



Speaker bracket

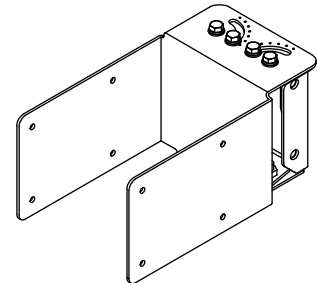

Hex bolt M6x20 (with spring and plain washers, paint) ... 8

Hex bolt M10x30 (with spring and plain washers, paint) ... 4

SR-D8HB Hoisting Bracket

Hoisting bracket

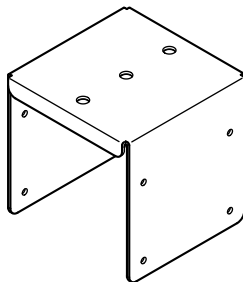

Eyebolt



Hex bolt M6x20 (with spring and plain washers, paint) ... 8

• SR-D8FB Fixing Bar



Hex nut M8 (with flange) ... 1

Hex bolt M8x25 (with spring and plain washers, for spare) ... 2

[Number of linked speakers and required joint brackets]

	Model No.	Single Unit	2-Unit Configuration	3-Unit Configuration	4-Unit Configuration
Speaker	SR-D8-M	1	1	1	1
	SR-D8-S	0	1	2	3
Bracket	SR-D8EP	0	1	2	3
	SR-D8WB	2	2	3	4
	SR-D8FB*	2	2	3	4
	SR-D8CS	1	0	0	0
	SR-D8CL	0	1	2	3
	SR-D8HB	0	1	1	1

* Use only when setting left or right angles to over 45°.

9. COMMUNICATIONS BETWEEN PC AND SPEAKERS

Connect the PC to the SR-D8-M's/SR-D8-S's LAN connection terminal via a switching hub.
Use a straight through cable (STP Category 5 or higher cable fitted with RJ45 connectors) for connection.
Up to 4 stacks (up to 16 speakers) can be controlled by a single PC.

Note: Do not connect the LAN terminal directly to the PC.

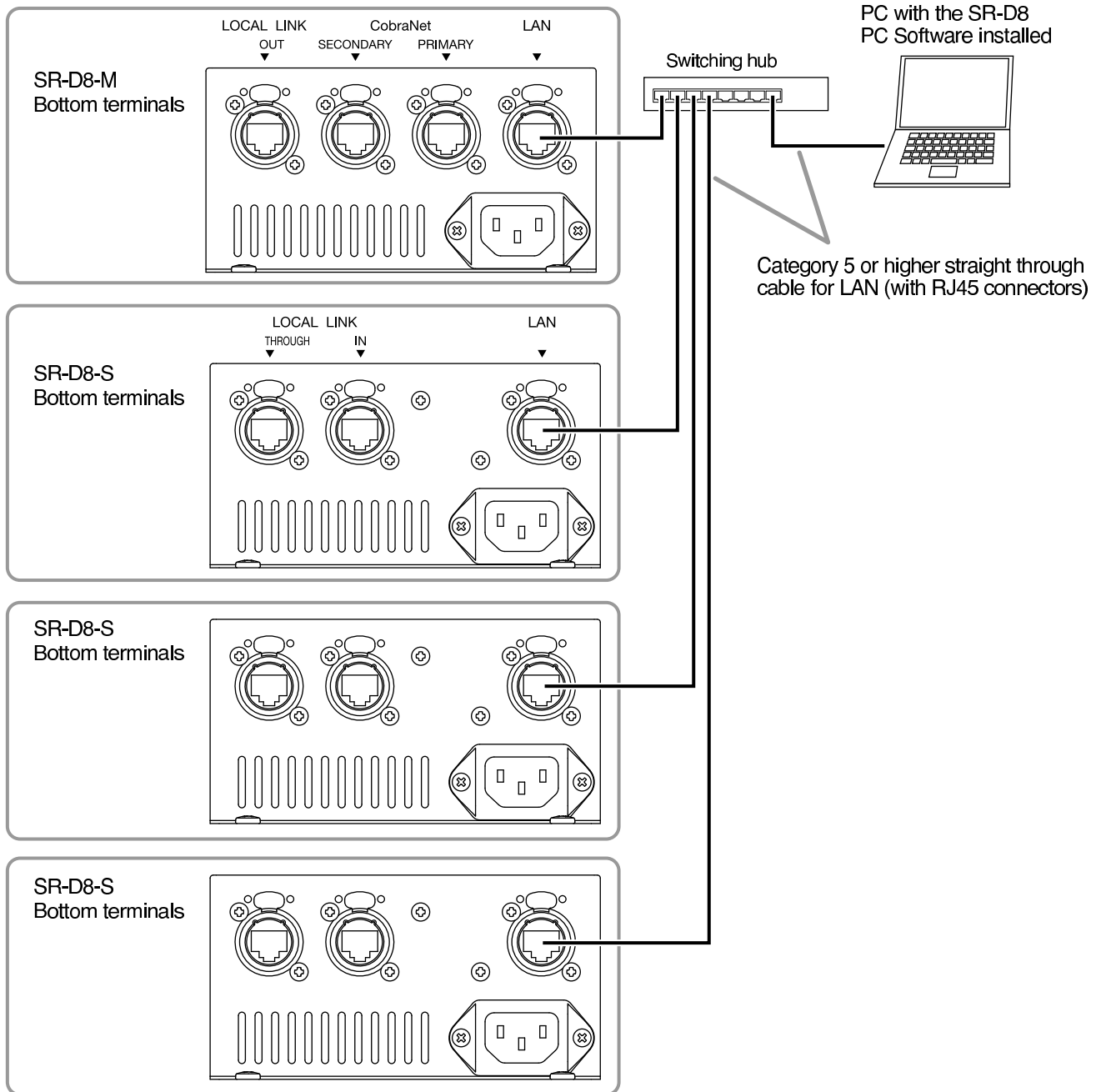

10. CONNECTIONS

10.1. Connection Example 1 (CobraNet Connection)

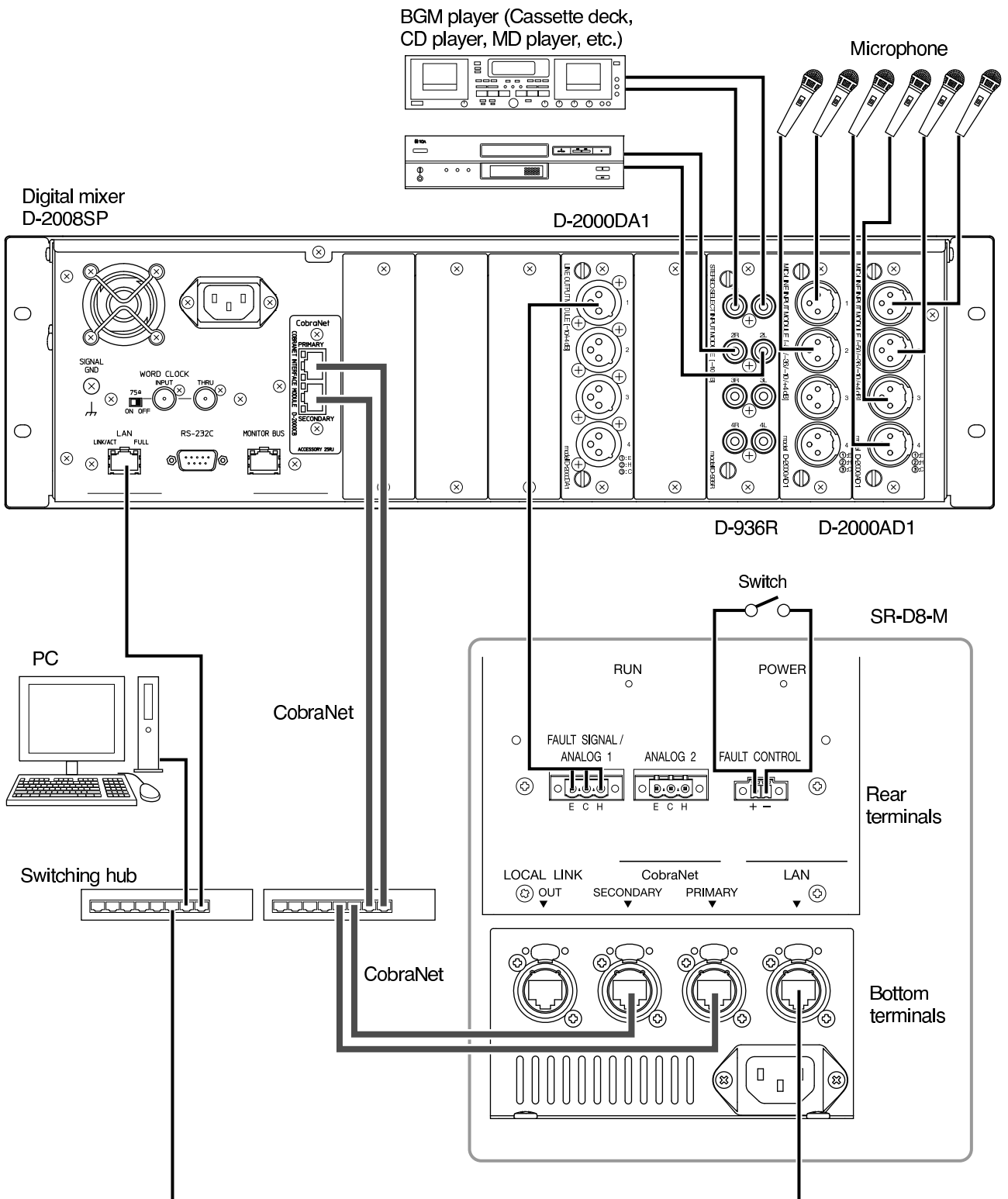

10.2. Connection Example 2 (CobraNet Connection, 4-Unit Configuration)

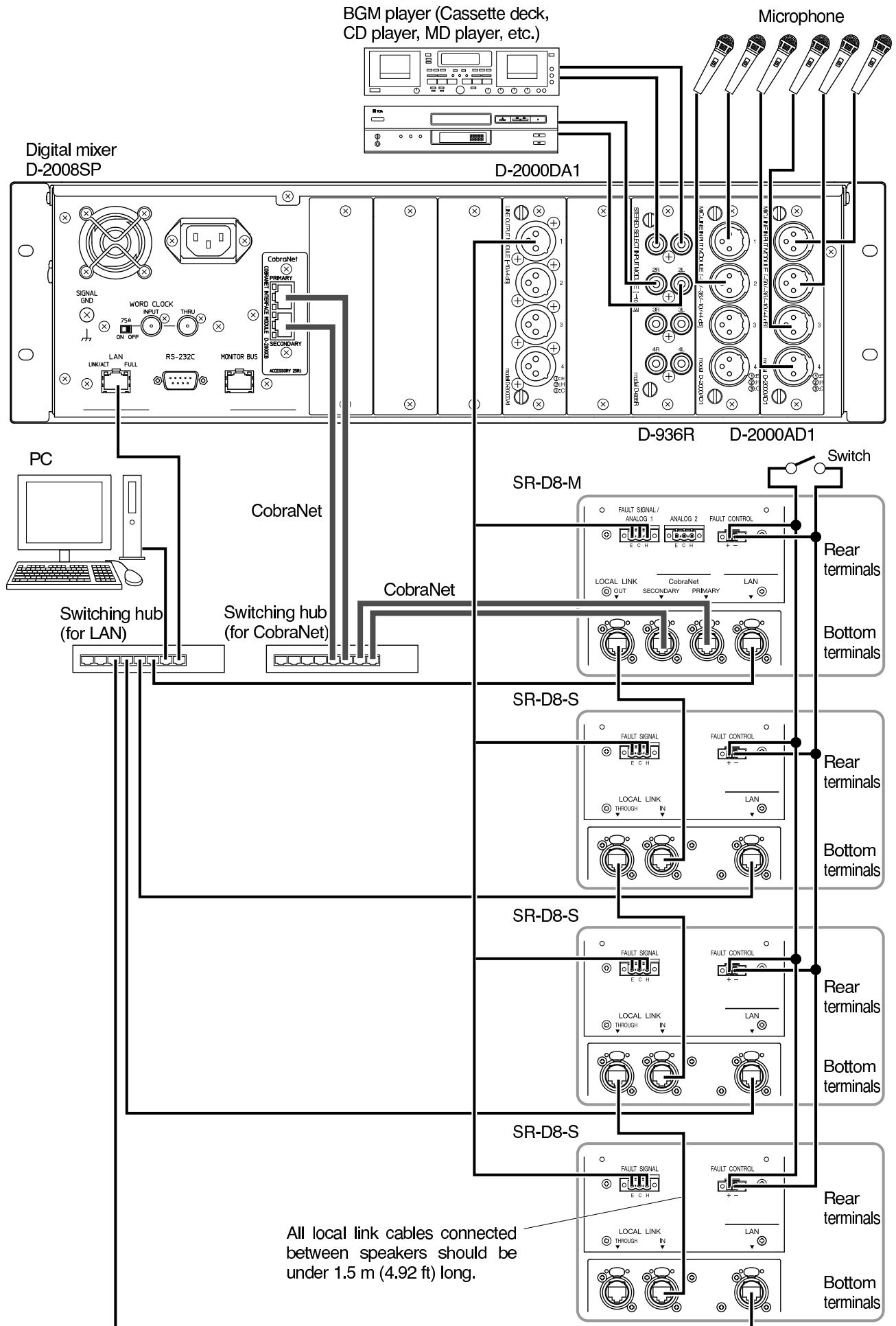

10.3. Connection Example 3 (Analog Line Connection)

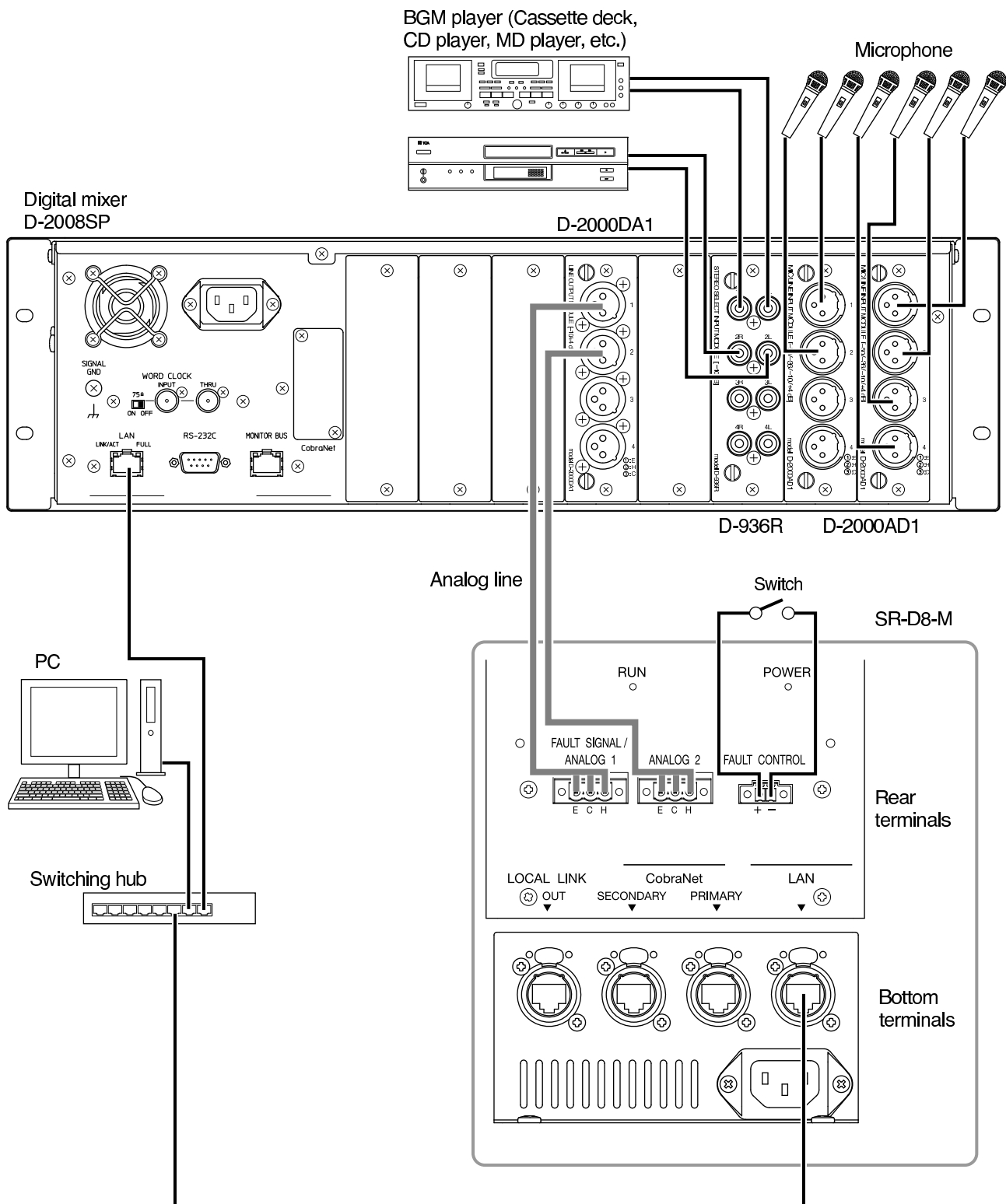

10.4. Connection Example 4 (Maximum System)

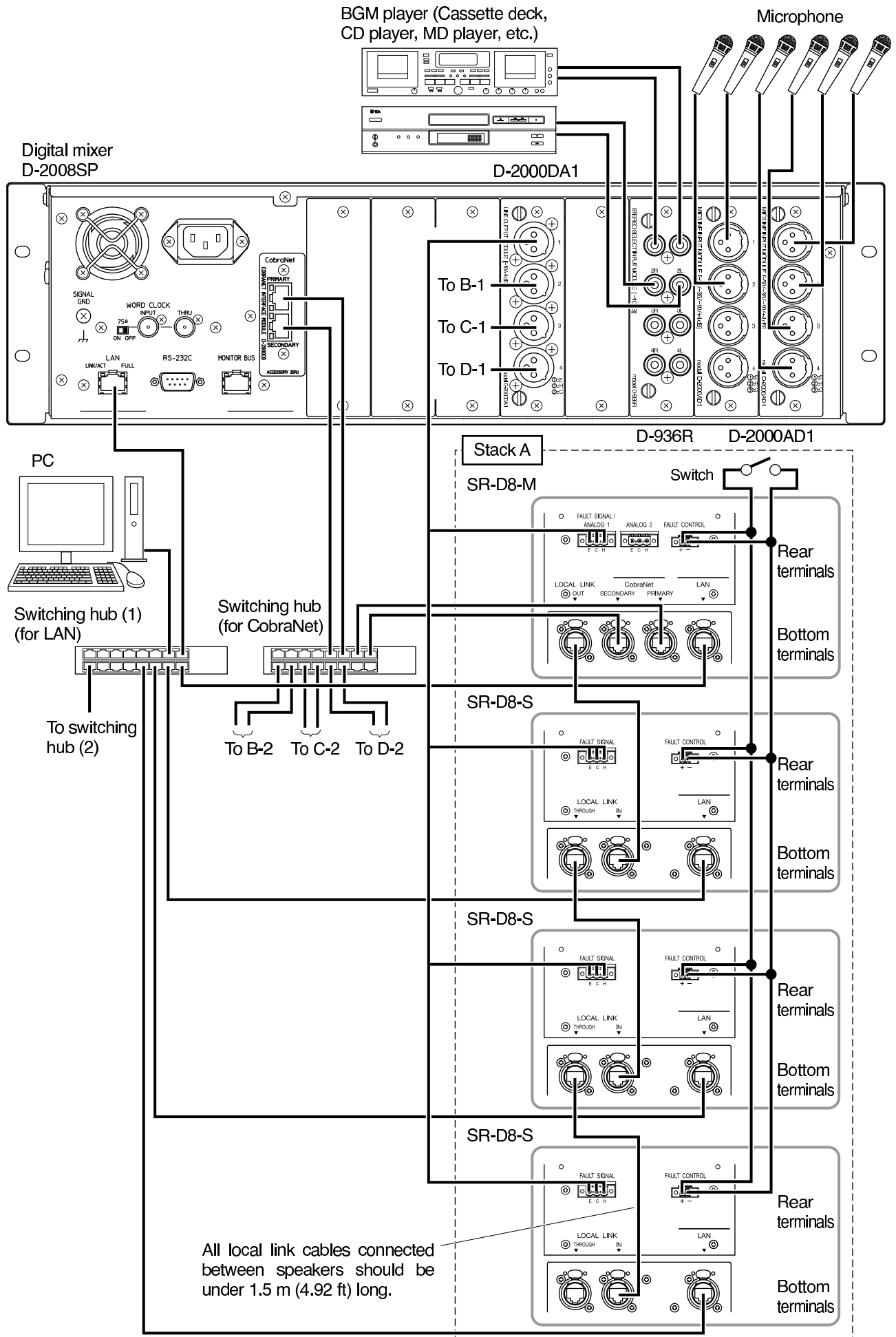

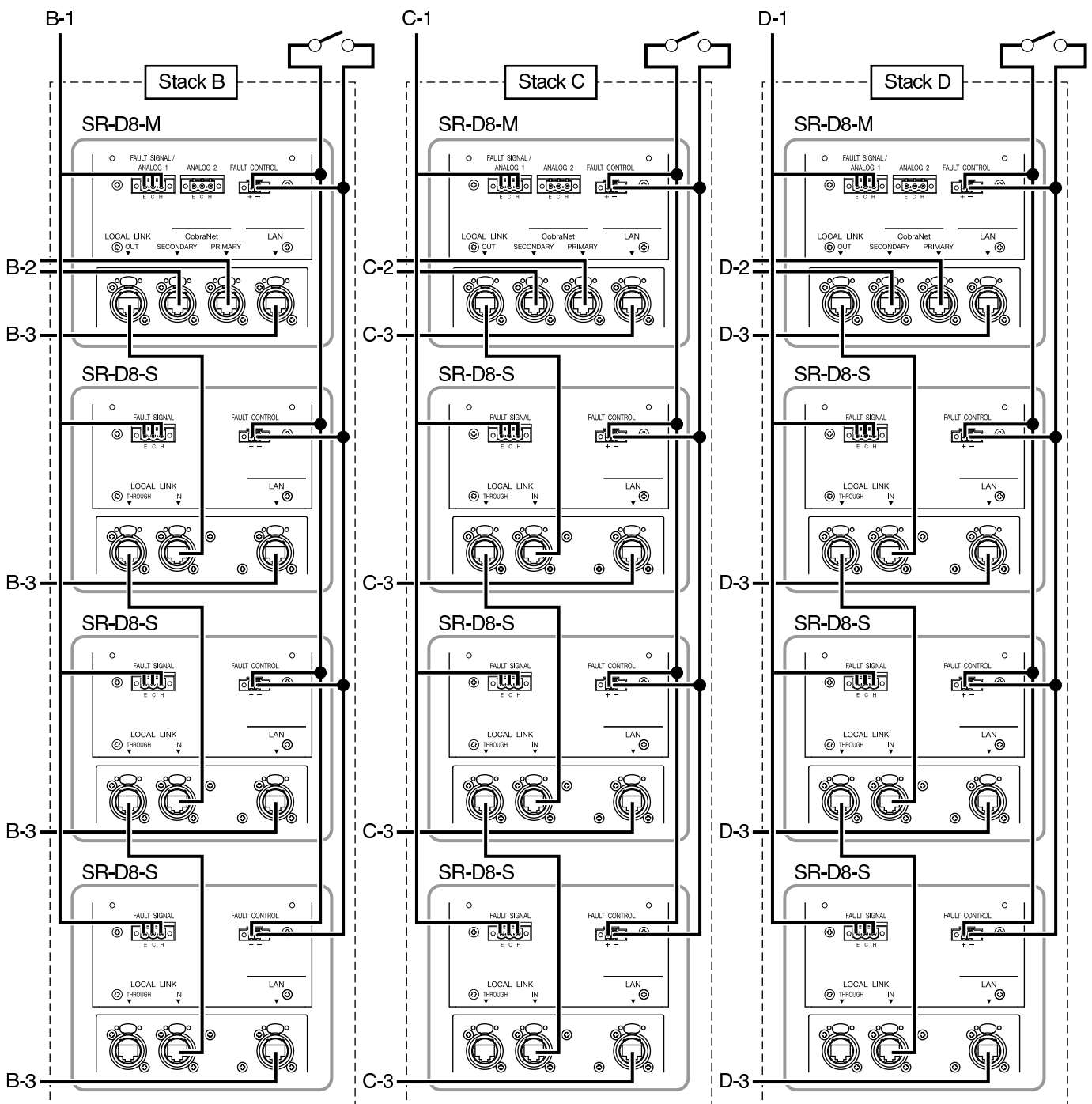
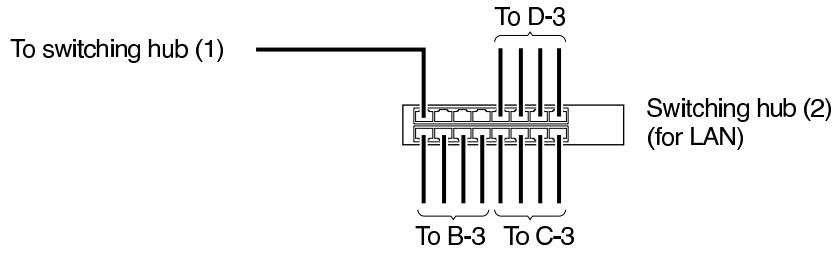

10.5. Removable Terminal Plug Connection

Notes

- Avoid soldering stranded or shielded cable, as contact resistance may increase when the cable is tightened and the solder is crushed, possibly resulting in an excessive rise in joint temperatures.
- When connecting 2 cables or a shielded cable to a single terminal, use a ferrule terminal with an insulation sleeve to crimp the cables because such cable conductors could become loose. Use the No. 4 ferrule terminal when connecting 2 cables to a single terminal.

- Recommended ferrule terminals for all removable terminal plugs (made by Phoenix Contact)

Unit: mm (in)

	Model Number	a	b	l ₁	l ₂
①	AI 0,34-8 TQ	2 (0.08)	0.8 (0.03)	12.5 (0.49)	8 (0.31)
②	AI 0,5-8 WH	2.5 (0.1)	1.1 (0.04)	14 (0.55)	8 (0.31)
③	AI 1,5-8 BK	3.4 (0.13)	1.8 (0.07)	14 (0.55)	8 (0.31)

	Model Number	a ₁	a ₂	b	l ₁	l ₂
④	AI-TWIN 2x0,5-8 BK	6.6 (0.26)	3.6 (0.14)	2.3 (0.09)	16 (0.63)	8 (0.31)

Crimping tool: CRIMPFOX UD6-4 (made by Phoenix Contact)

Note: The No. 3 ferrule terminal cannot be used for the Fault contact input terminal (5) on p. 9.

- Cables vs. recommended terminals
 - AWG 22 cable: No. 1 ferrule terminal
 - AWG 20 cable: No. 2 ferrule terminal
 - AWG16 cable: No. 3 ferrule terminal
 - 2 x 0.5 mm² (AWG 20) cable: No. 4 ferrule terminal

- Cable sheath to trim

Solid cable and stranded cable

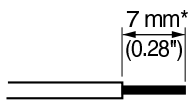

Shielded cable

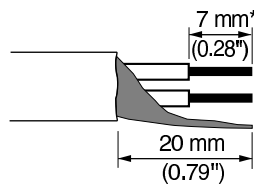

* Expose 8 mm (0.31") or more when using the above ferrule terminal, and cut off an extra conductor protruding from the sleeve.

- Wiring procedures

Step 1. Connect the wire to the supplied removable terminal plug.

1-1. Loosen the terminal screws to insert the wire.

1-2. Tighten the terminal screws.

Ensure that the wire does not break free when pulled. If the wire does pull free, repeat the connection procedure from the start.

Step 2. Insert the wired terminal plug into the corresponding terminal block in the unit's rear panel.

Step 3 Tighten the fixing screws.

Note

Do not reverse Steps 1 and 2 above.

Force is applied to the connected receptacle pins while tightening the terminal screw and they may be damaged, resulting in bad connector contact.

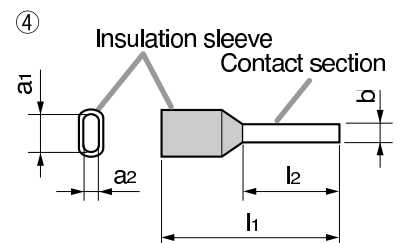
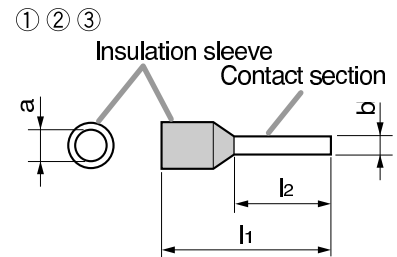

- Connections to ferrule terminals

[Connecting a single wire to one terminal]



[Connecting two wires to one terminal]

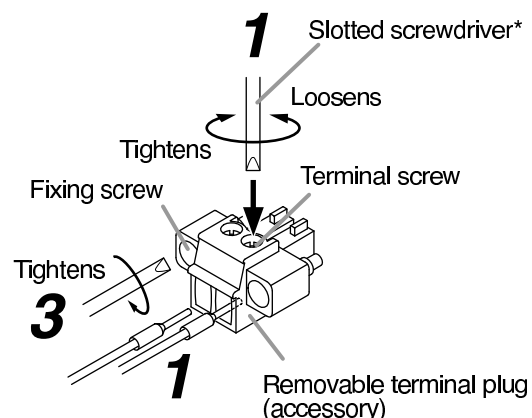
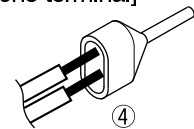

* Recommended slotted screwdriver type:
Screwdriver with blade that is 2.5 mm (0.1") in width

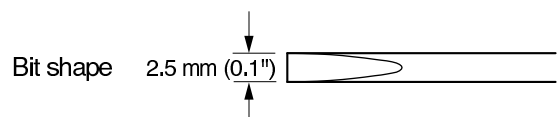

10.6. Fixing Power Supply Cord

To prevent the power supply cord from being accidentally pulled out, fix it using the supplied cord clamp as shown at right.

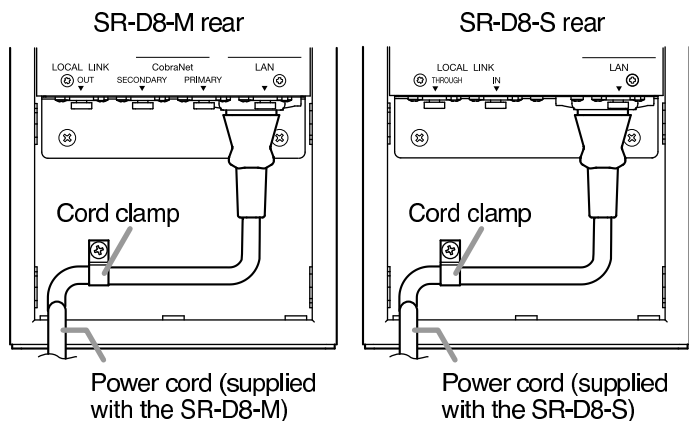

10.7. System Expansion Using CobraNet Connection

10.7.1. CobraNet connection outline

The system can be expanded by connecting the SR-D8-M's CobraNet terminals to the D-2008SP with the D-2000CB CobraNet Interface Module.

Connect the SR-D8-M to the D-2008SP via a switching hub. Connect each of CobraNet Primary and Secondary ports of the SR-D8-M to the same switching hub or different switching hubs connected in cascade.

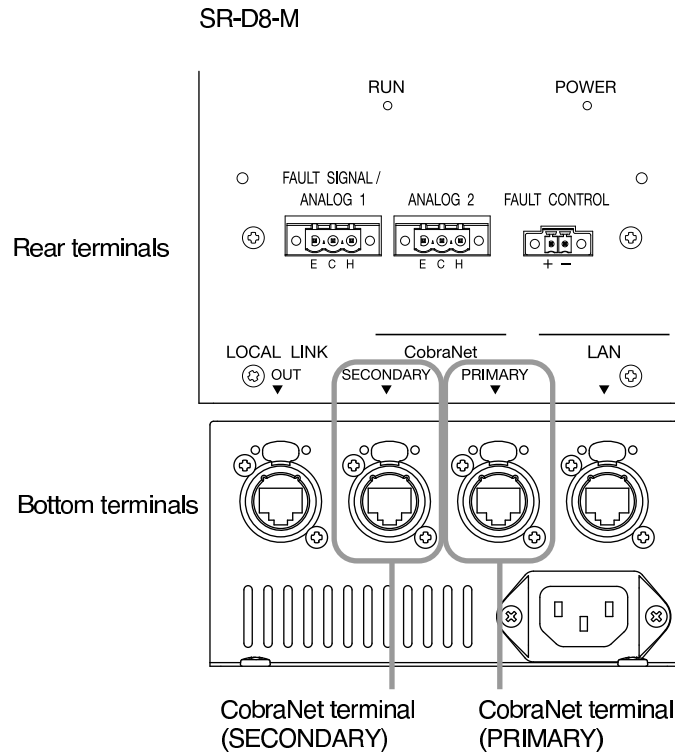

Notes

- Make the CobraNet terminals completely independent from other LAN.
- The distance between each of the SR-D8-M and the switching hub is less than 100 m (110 yd).
- Be sure to make connections of both terminals PRIMARY and SECONDARY.
- Audio signals may be interrupted temporarily at the time of switching between PRIMARY and SECONDARY ports.
- When connecting CobraNet terminal PRIMARY or SECONDARY to multiple switching hubs, be sure to connect the hubs in cascade.
- Up to 7 switching hubs can be connected in cascade. The number of switching hubs between the SR-D8-M and all CobraNet devices connected to the SR-D8-M should be 7 or less. (Refer to connection examples 1 and 2 on the next page.)
- When using multiple switching hubs, making star connection at the hub directly connected to the SR-D8-M as shown in Connection example 2 is highly recommended to reduce the number of cascade-connected hubs.

[Connection example 1: Redundant configuration of switching hubs]

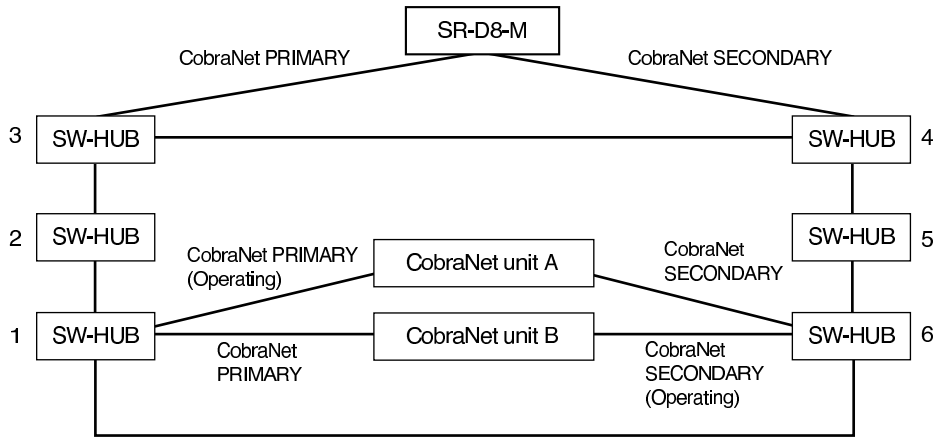

As shown in the example above, when the CobraNet unit A is operating via the CobraNet PRIMARY and the CobraNet unit B is operating via the CobraNet SECONDARY, 6 switching hubs are used for communications between both units. Therefore, in a redundant configuration of switching hubs*, the number of hubs cascade-connected from the SR-D8-M should be 3 or less.

* A method of connecting a single unit's CobraNet PRIMARY and SECONDARY terminals to each different switching hub to prevent the system from going down when a cable is broken or power fails.

[Connection example 2: Non-redundant configuration of switching hubs]

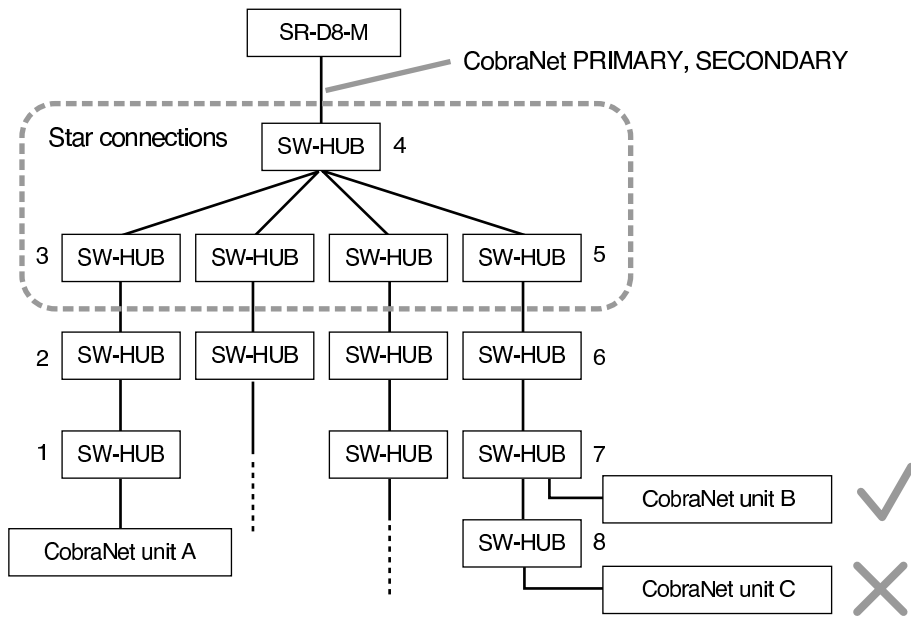

As 7 switching hubs are on the communication path from the CobraNet unit A to the CobraNet unit B, there is no problem for the system. However, as the number of hubs from the CobraNet unit A to the CobraNet unit C is 8, there may be a system failure.

10.7.2. Redundant configuration of switching hubs

Shown below is the connection example of the 4 stack configuration, in which each SR-D8-M is connected to switching hubs.

In the connection example below, the CobraNet PRIMARY and SECONDARY terminals of each unit are individually connected to different switching hubs. Even if any one of the switching hubs fails or Main line breaks, the system is kept operating using another Main line, thus preventing system down.

Notes

- Cycle the entire system's power after connection completion.
- Perform spanning tree setting within switching hubs. For the settings, refer to the instruction manual of the switching hub.
- Audio signals may be interrupted temporarily at the time when the network configuration automatically changes due to failure of any switching hub or disconnection of the main line.
- Contact your TOA dealer for more information on switching hubs.

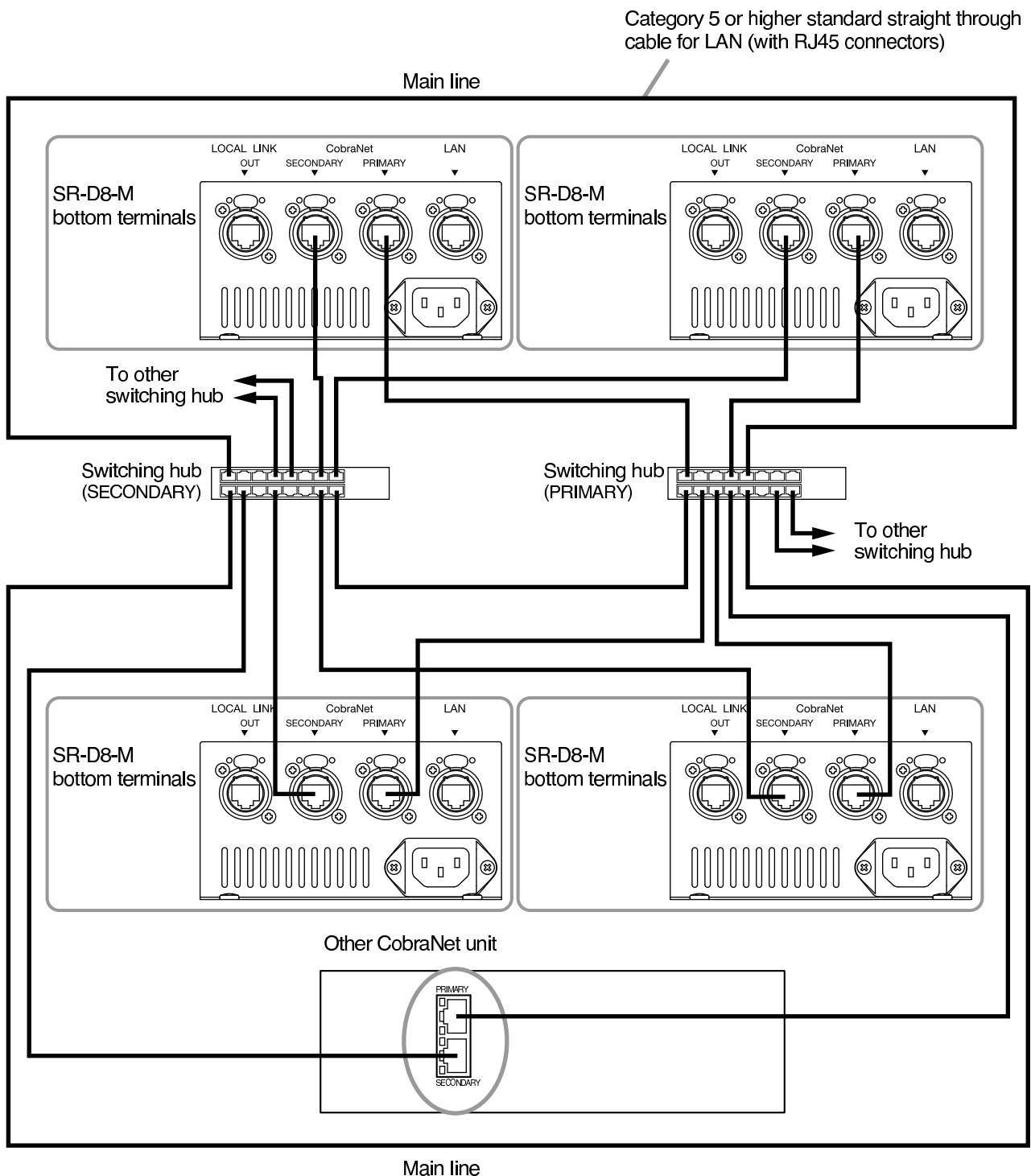

10.7.3. Non-redundant configuration of switching hubs

Shown below is the connection example of the 4 stack configuration, in which each SR-D8-M is connected to the same switching hub.

In the connection example below, both CobraNet PRIMARY and SECONDARY terminals of each unit are connected to the same switching hub.

Notes

- Cycle the entire system's power after connection completion.
- Contact your TOA dealer for more information on switching hubs.

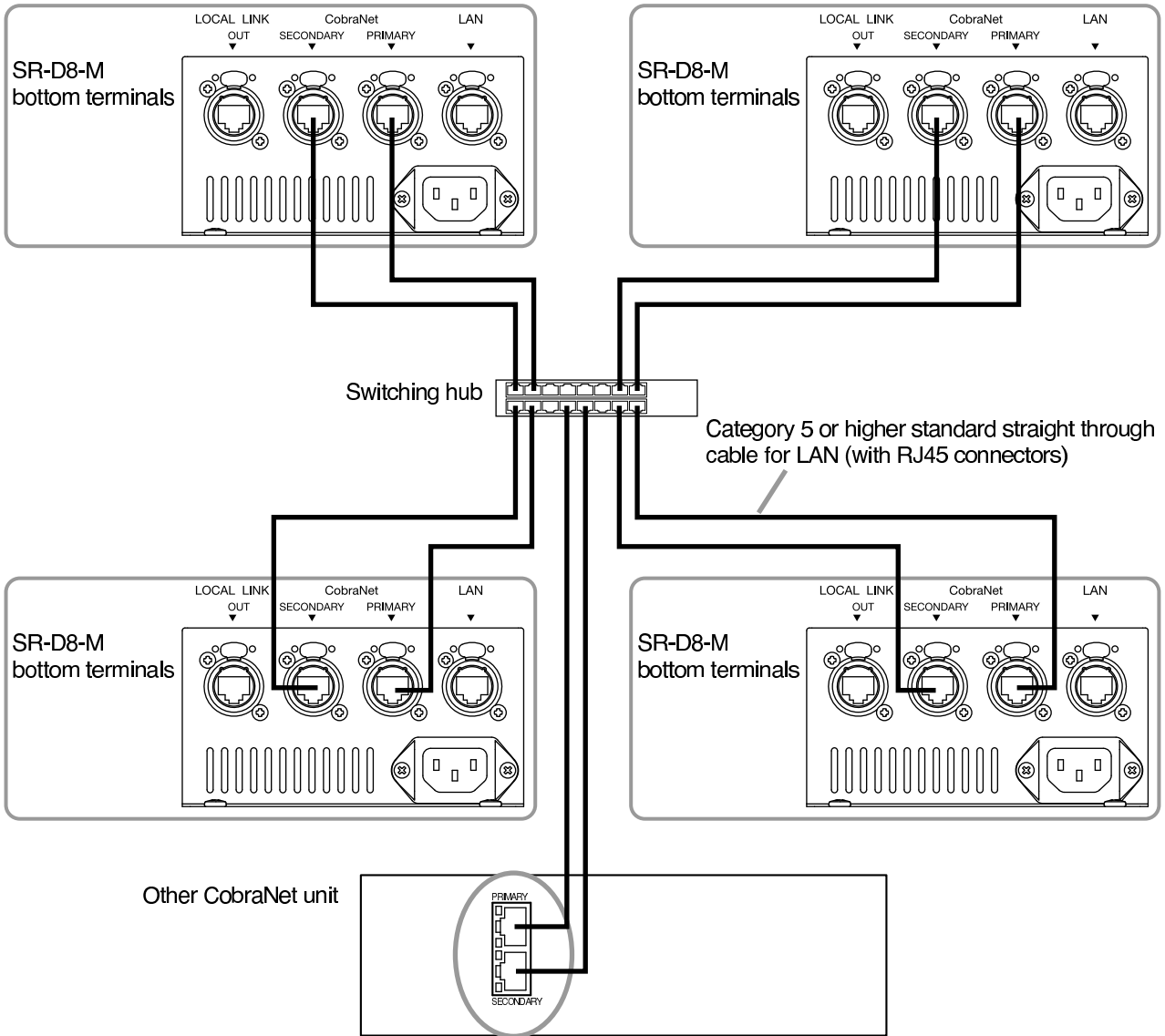

11. INSTALLATION

11.1. Installing a Single SR-D8-M Unit

WARNING

- Attach the safety wire, strong enough to withstand heavy load, to the unit.
- The apparatus shall be connected to a mains socket outlet with a protective earthing connection.
- The socket-outlet shall be installed near the equipment and the plug (disconnecting device) shall be easily accessible.
- Do not use this speaker in a flying installation.
- Only install speaker units in locations that can structurally support the weight of the speaker and its mounting brackets (Total weight: 31 kg or 68.34 lb).
- Nuts and bolts used for wall mounting are not supplied with the unit. Use hardware appropriate to the wall's structure and composition.
- Never install the unit on the wall tilting over 30°.
- Never adjust the speaker angle to the left or right when the unit is installed facing up or down.

11.1.1. Required mounting brackets

Mounting Bracket	Number	Remark
SR-D8WB Wall Mounting Bracket	2	Arrange 9 sets of M10 anchor bolts and M10 nuts separately.
SR-D8CS Wall Mounting Adapter	1	
SR-D8FB Fixing Bar	2	Use when setting left or right angles to over 45°.

11.1.2. Wall mounting

Step 1. Install anchor stud bolts in the wall (see the figure at right).

Bracket Mounting Anchor Stud Bolts (M10)

To determine stud bolt projection from the wall surface, refer to the dimensions indicated below:

[Single nut]

18 – 30
(0.71 – 1.18)

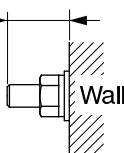

Unit: mm (in)

[Double nut]

25 – 30
(0.98 – 1.18)

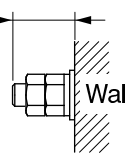

[Anchor Stud Bolt Mounting Dimensions]

Unit: mm (in)

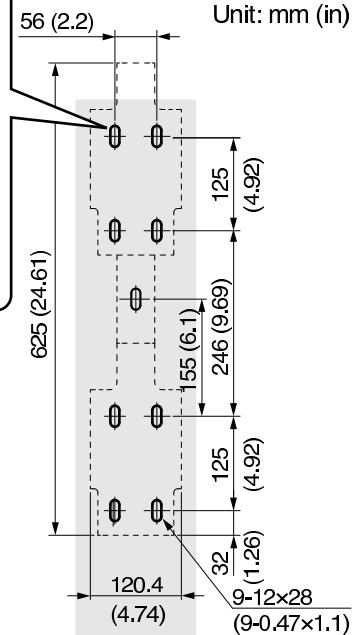

Step 2. Assemble the bracket sets to be mounted to the wall.

Step 3. Mount the assembled bracket sets to the wall.

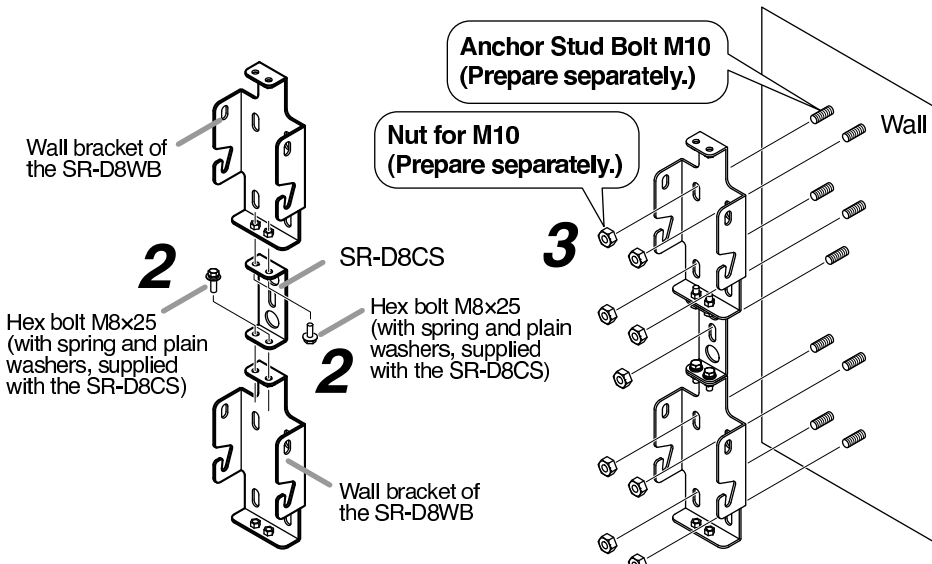

Note

Gray area indicates speaker mounting position.

Step 4. Remove screws from speaker sides.

Step 5. Securely tighten 6 angle adjustment bolts (4 on the upper side and 2 on the lower side) of each speaker bracket, then attach each bracket to the speaker.

Step 6. Loosely tighten bolts in the mounting holes located on both sides of the lower part of each speaker bracket.

Step 7. Hang the loosely tightened bolts on the wall bracket.

Step 8. Install bolts in left- and right-side mounting holes located in the upper part of the speaker bracket.

Step 9. Securely tighten all bolts.

[Completed Mounting]

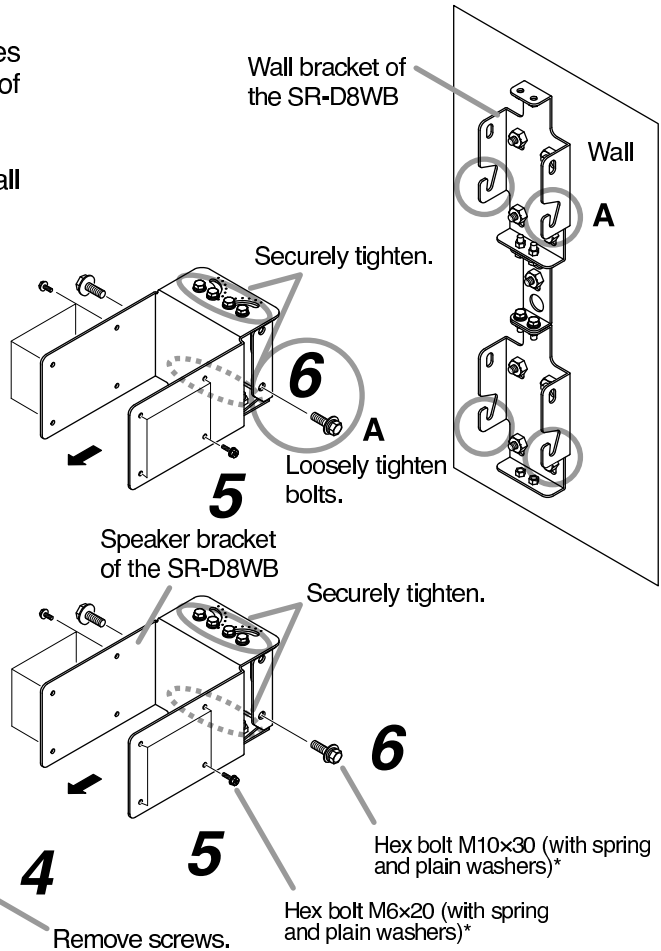
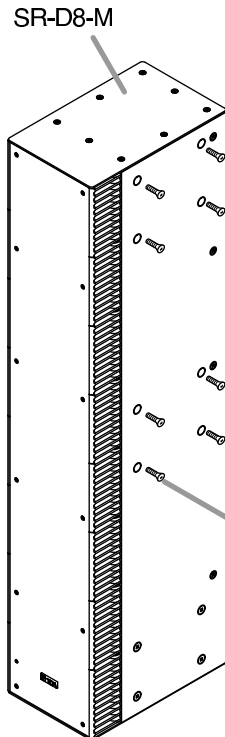
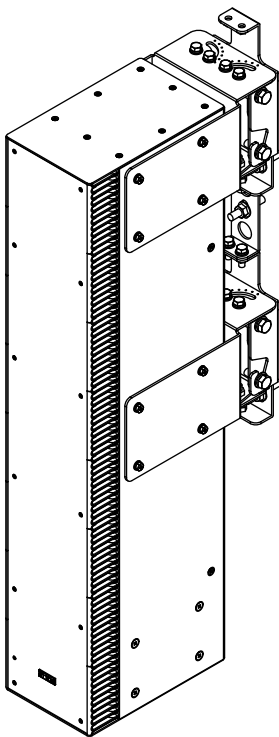

Note
The removed screws are not used.

* Supplied with the SR-D8WB

[Enlarged figure of Part A]

[Completed Dimensional Diagram]

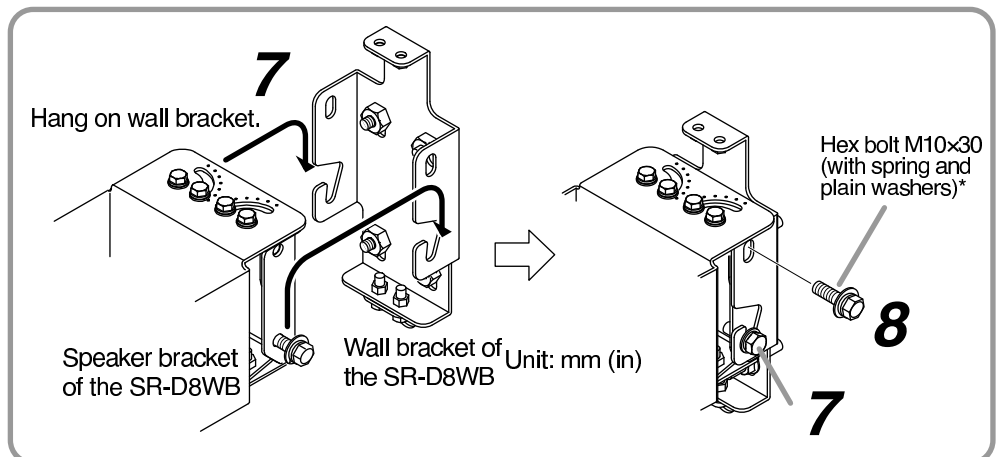
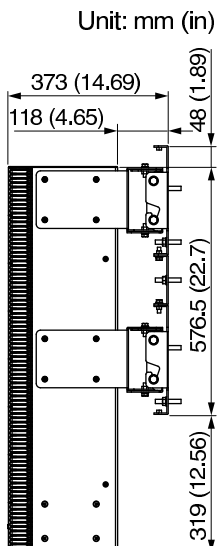

Note

Left and right angles can be adjusted within a range of 0° – 90°. If no angle adjustments are required, this completes the installation. When performing angle adjustments, please refer to “Angle Adjustment” on p. 31.

11.2. Installing SR-D8-M and SR-D8-S(s) in multi-unit configuration

Up to 3 SR-D8-S speaker units can be connected in series to one SR-D8-M.

WARNING

- Attach the safety wire, strong enough to withstand heavy load, to the unit.
- The apparatus shall be connected to a mains socket outlet with a protective earthing connection.
- The socket-outlet shall be installed near the equipment and the plug (disconnecting device) shall be easily accessible.
- Do not use this speaker in a flying installation.
- Only install speaker units in locations that can structurally support the weight of the speaker and its mounting brackets (Total weight ... 2-Unit Configuration: 57 kg or 125.66 lb, 3-Unit Configuration: 88 kg or 194 lb, 4-Unit Configuration: 118 kg or 260.14 lb).
- Nuts and bolts used for wall mounting are not supplied with the unit.
Use hardware appropriate to the wall's structure and composition.
- Never install the unit on the wall tilting over 30°.
- Never adjust the speaker angle to the left or right when the unit is installed facing up or down.

11.2.1. Required mounting brackets

[2-Unit Configuration]

Mounting Bracket	Number	Remark
SR-D8EP Extension Plate	1	
SR-D8WB Wall Mounting Bracket	2	Arrange 9 sets of M10 anchor bolts and M10 nuts separately.
SR-D8CL Wall Mounting Adapter	1	
SR-D8HB Hoisting Bracket	1	
SR-D8FB Fixing Bar	2	Use when setting left or right angles to over 45°.

[3-Unit Configuration]

Mounting Bracket	Number	Remark
SR-D8EP Extension Plate	2	
SR-D8WB Wall Mounting Bracket	3	Arrange 14 sets of M10 anchor bolts and M10 nuts separately.
SR-D8CL Wall Mounting Adapter	2	
SR-D8HB Hoisting Bracket	1	
SR-D8FB Fixing Bar	3	Use when setting left or right angles to over 45°.

[4-Unit Configuration]

Mounting Bracket	Number	Remark
SR-D8EP Extension Plate	3	
SR-D8WB Wall Mounting Bracket	4	Arrange 19 sets of M10 anchor bolts and M10 nuts separately.
SR-D8CL Wall Mounting Adapter	3	
SR-D8HB Hoisting Bracket	1	
SR-D8FB Fixing Bar	4	Use when setting left or right angles to over 45°.

11.2.2. Wall mounting

Below is the procedure for installation in 2-unit configuration.

Step 1. Install anchor stud bolts in the wall (see the figure in the lower right).

Note: For mounting dimensions in 3-unit and 4-unit configurations, see p. 30.

Step 2. Assemble the bracket sets to be mounted to the wall.

Step 3. Mount the assembled bracket sets to the wall.

**[Anchor Stud Bolt Mounting Dimensions
(2-Unit Configuration)]**

Unit: mm (in)

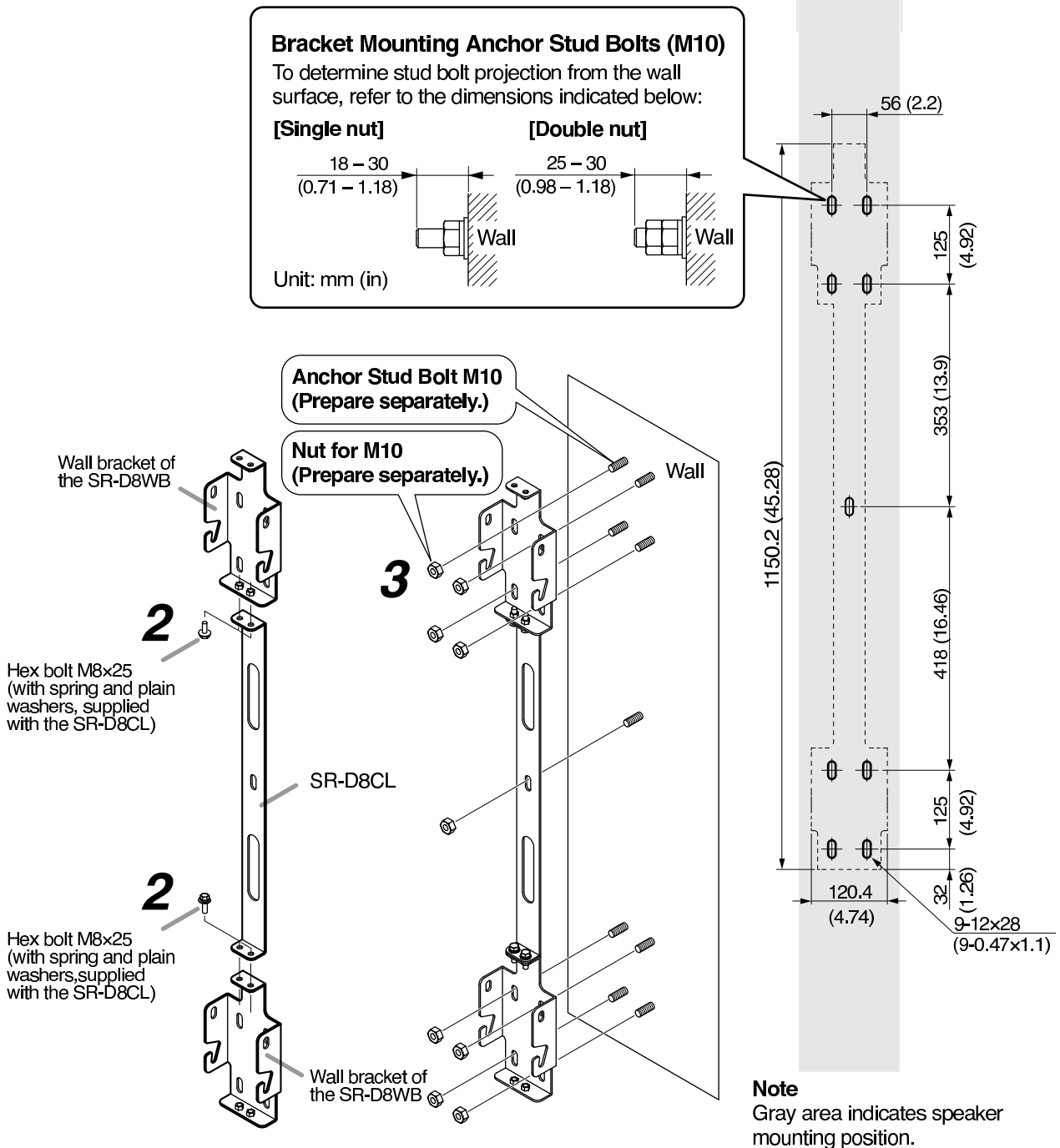

Step 4. Remove screws from speaker sides.

Step 5. Attach each speaker bracket to the speaker.

Bracket	Mounting position	Remark
Hoisting Bracket	On top of the speaker stack	Mount an eyebolt. Use only for hoisting the speaker stack at speaker installation.
Speaker Bracket	Center of each speaker	Securely tighten 6 angle adjustment bolts (4 on the upper side and 2 on the lower side) of each speaker bracket, then attach each bracket to the speaker.
Extension Plate	Joint part of speakers	

Step 6. Loosely tighten bolts in the mounting holes located on both sides of the lower part of each speaker bracket.

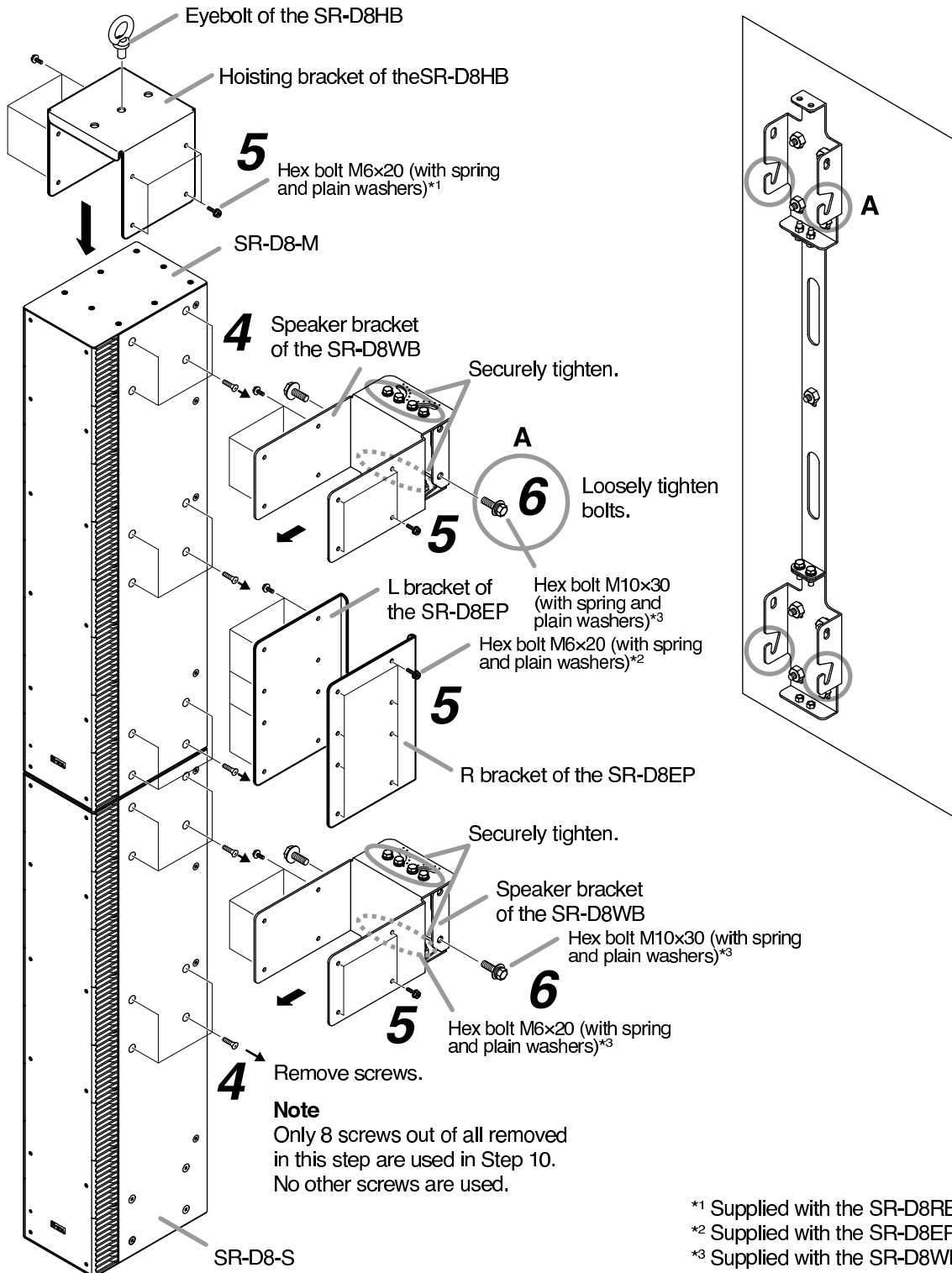

Step 7. Hang the loosely tightened bolts on the wall bracket.

Step 8. Install bolts in left- and right-side mounting holes located in the upper part of the speaker bracket.

Step 9. Securely tighten all bolts.

Step 10. Remove the hoisting bracket, then replace the 8 screws removed in Step 4.

Tip

The performance of the speaker is maintained even if the bracket is mounted as it is.

Note

Left and right angles can be adjusted within a range of 0° – 90°.

If no angle adjustments are required, this completes the installation. When performing angle adjustments, please refer to “Angle Adjustment” on p. 31.

[Completed Mounting (2-Unit Configuration)]

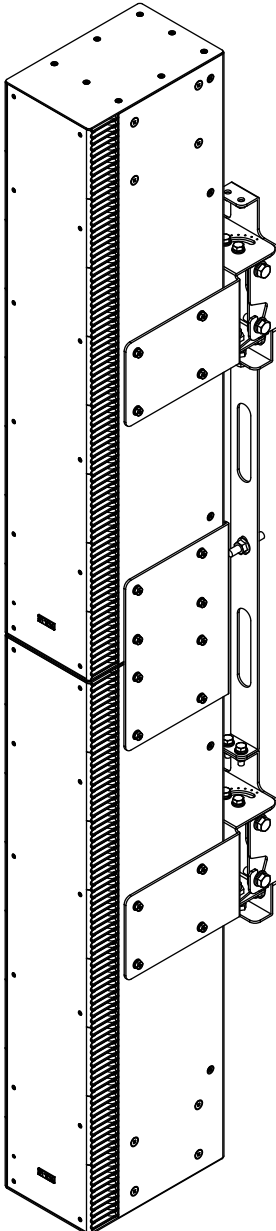

[Enlarged figure of previous page Part A]

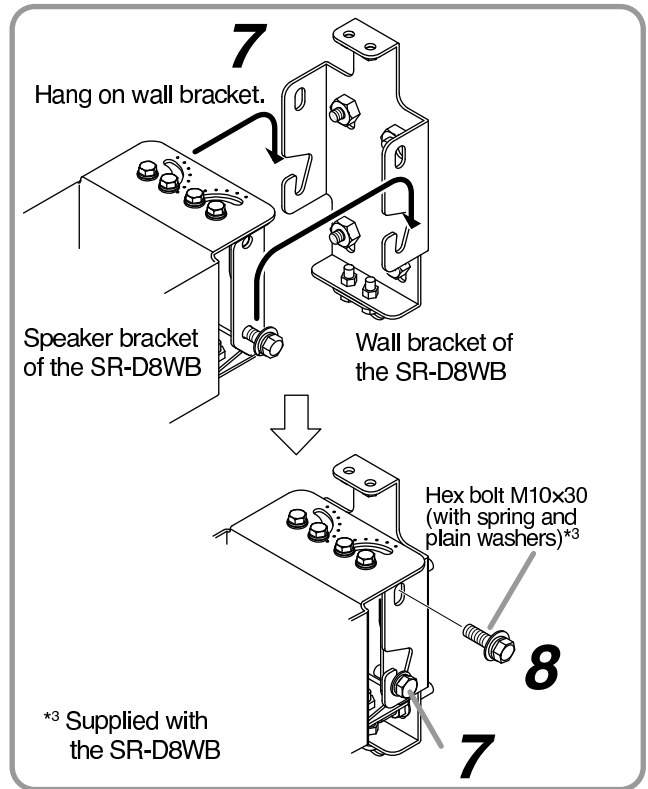

[Completed Dimensional Diagram (2-Unit Configuration) with Hoisting Bracket Mounted]

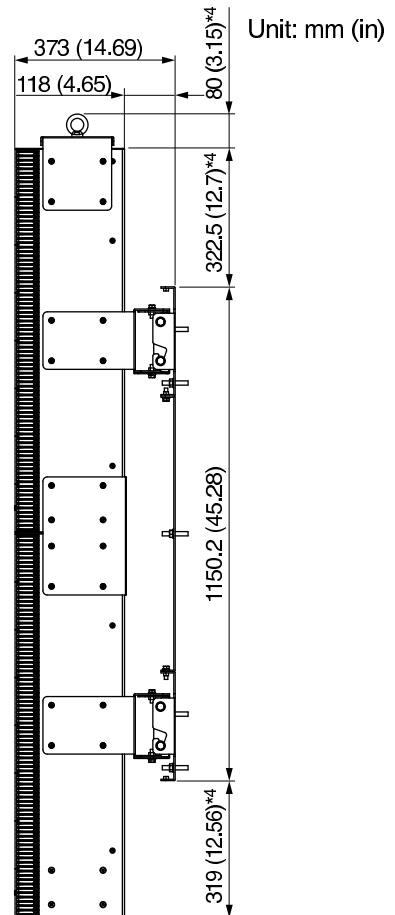

*4 These dimensions are the same as those in 3-unit and 4-unit configurations.

Note: For Completed Mountings and Completed Mounting Dimensional Diagrams in 3-unit and 4-unit configurations, see p. 30.

Wall mounting methods for 3-unit and 4-unit configurations are the same as the mounting method for 2-unit configuration.

Mount the speakers referring to the diagrams as shown below.

3-Unit Configuration

4-Unit Configuration

Unit: mm (in)

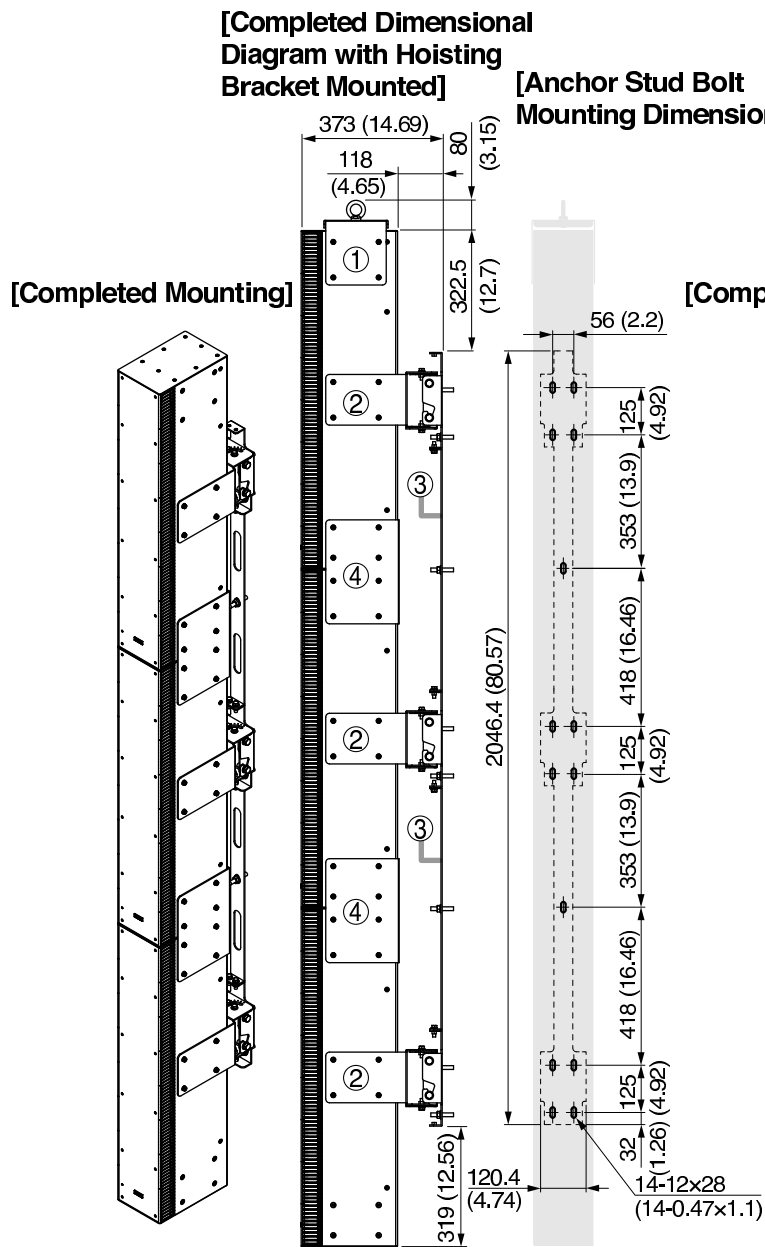

Note
Gray area indicates speaker mounting position.

- ① SR-D8HB
- ② SR-D8WB
- ③ SR-D8CL
- ④ SR-D8EP

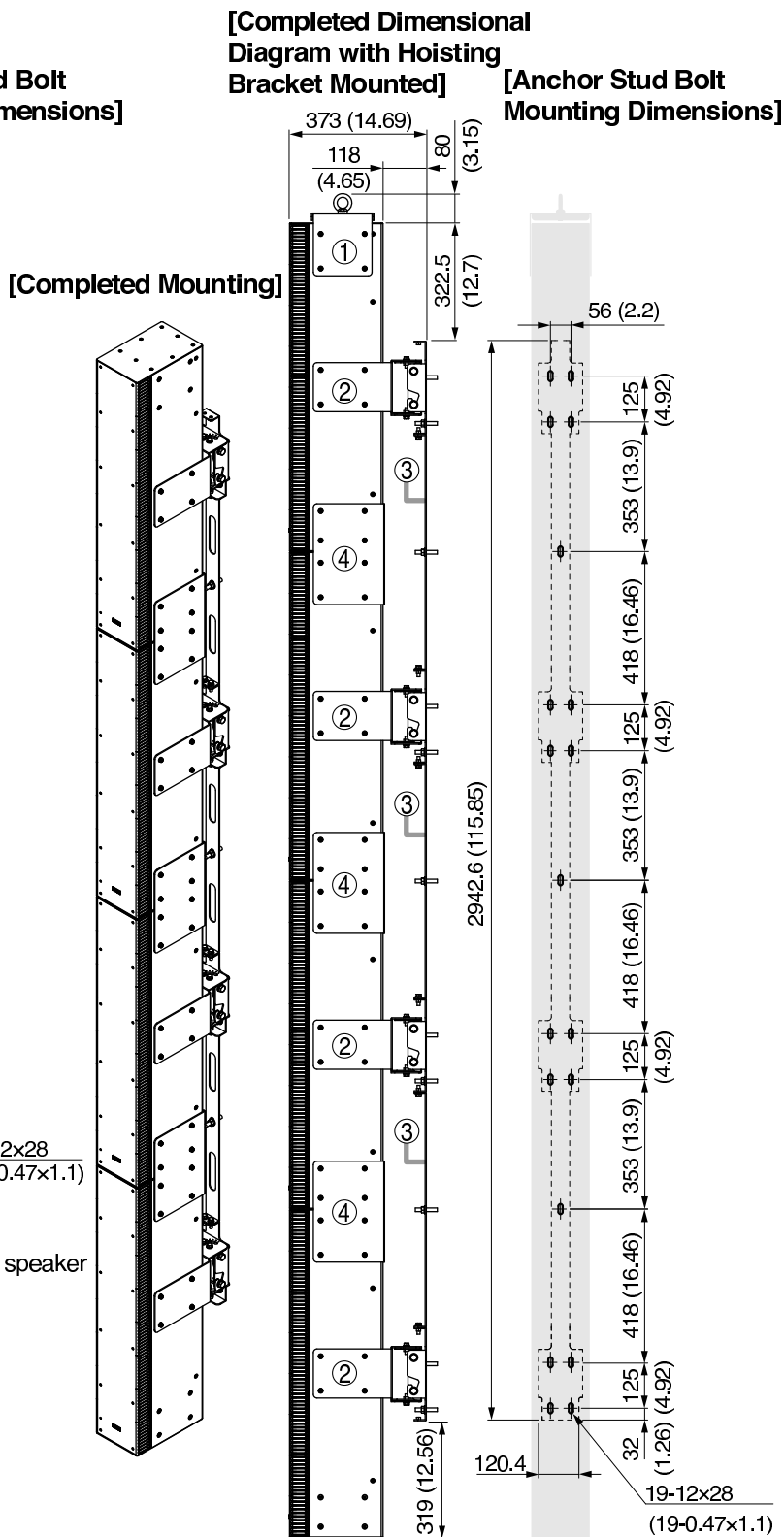

Note
Gray area indicates speaker mounting position.

11.3. Angle Adjustment



WARNING

Never adjust the speaker angle to the left or right when the speaker unit is installed facing up or down.

11.3.1. Adjusting the angle to the left or right within 45°

Step 1. Remove or loosen the bolts on the speaker bracket's upper and lower sides.
Perform this work for all speaker brackets.

Step 2. Direct the speaker unit to your desired angle.
As a rough guide, refer to the angle holes provided at 15° intervals in the speaker bracket.

Step 3. Securely tighten the loosened bolts.

Note

The removed bolts in **Step 1** are not used.

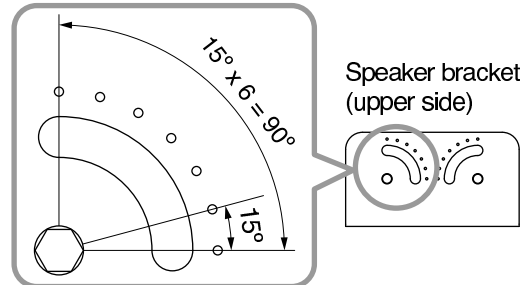

[When directing to the left facing the speaker front]

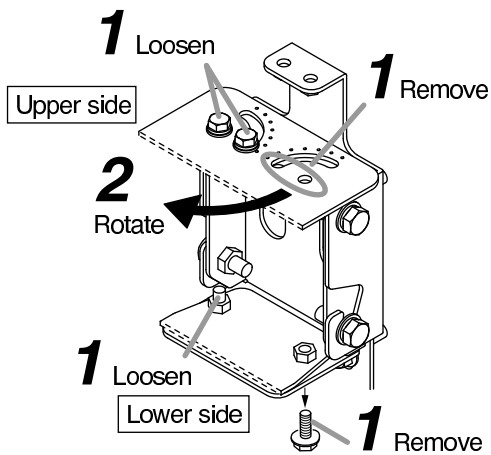

[When directing to the right facing the speaker front]

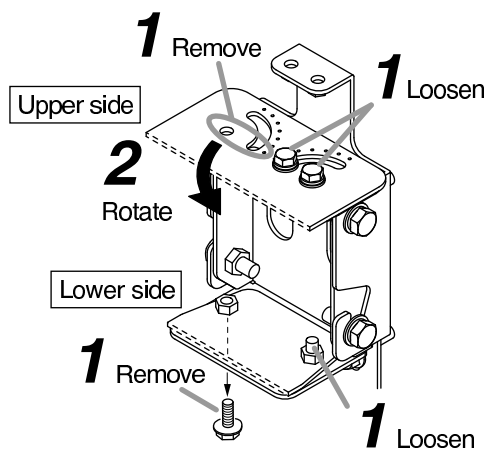

[Example of directing 30° to the left facing the speaker front]

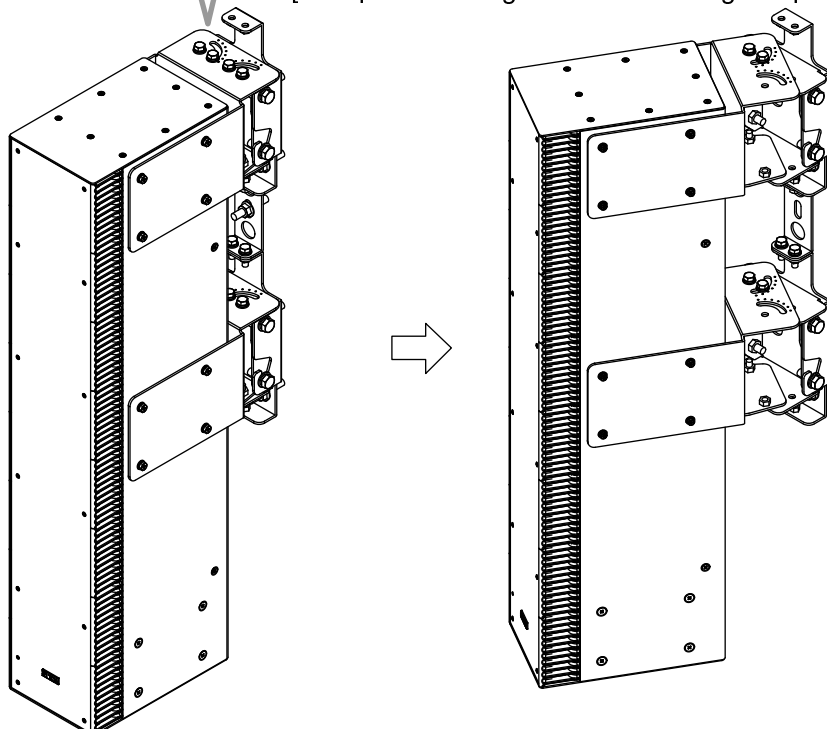

11.3.2. Adjusting the angle to the left or right over 45°

Step 1. Remove or loosen the bolts on the speaker bracket's upper and lower sides. Perform this work for all speaker brackets.

Step 2. Direct the speaker unit to an angle of 45°. As a rough guide, refer to the angle holes provided at 15° intervals in the speaker bracket.

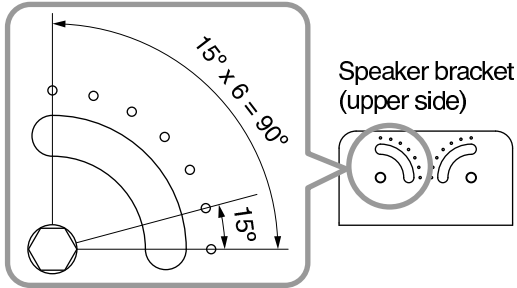

Step 3. Loosely secure the SR-D8FB Fixing Bar to the speaker bracket's upper side. Perform this work for all speaker brackets. Use 2 of the removed bolts in Step 1 and a nut supplied with the SR-D8FB.

Step 4. Direct the speaker unit to your desired angle.

Step 5. Securely tighten all loosened bolts and nuts.
Note
 The removed bolts except those used in **Step 3** are not used.

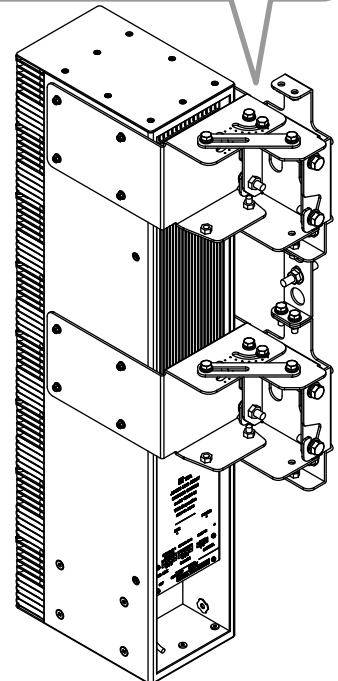
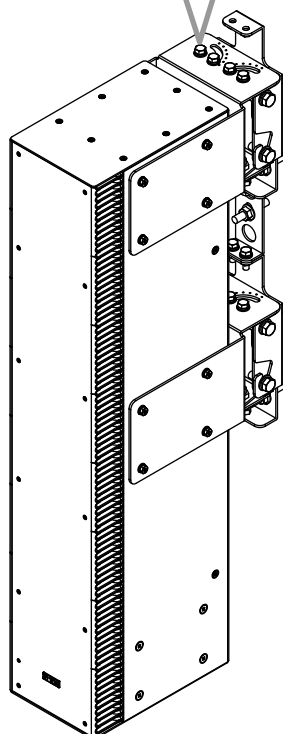
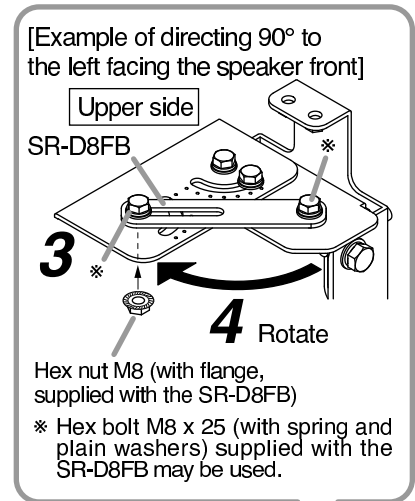
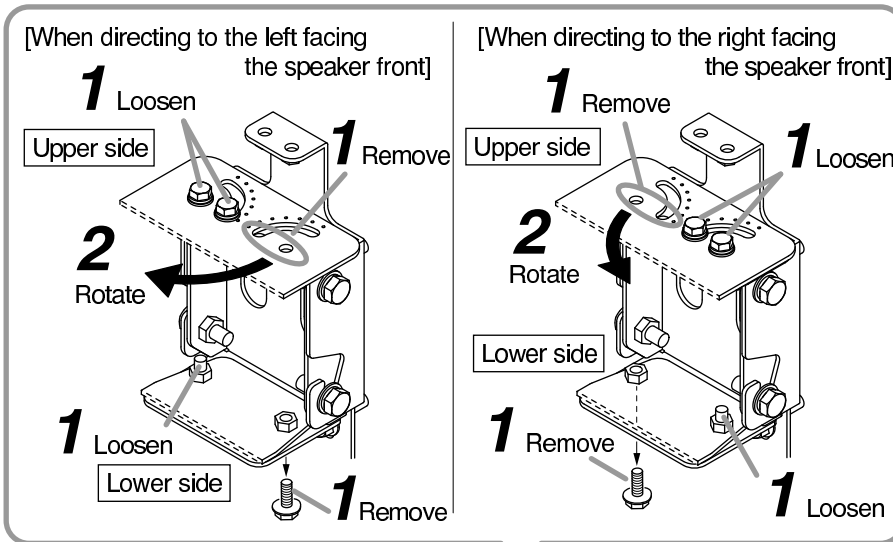

12. DIMENSIONAL DIAGRAMS

12.1. SR-D8-M, SR-D8-S Active Line Array Speaker Systems

Unit: mm (in)

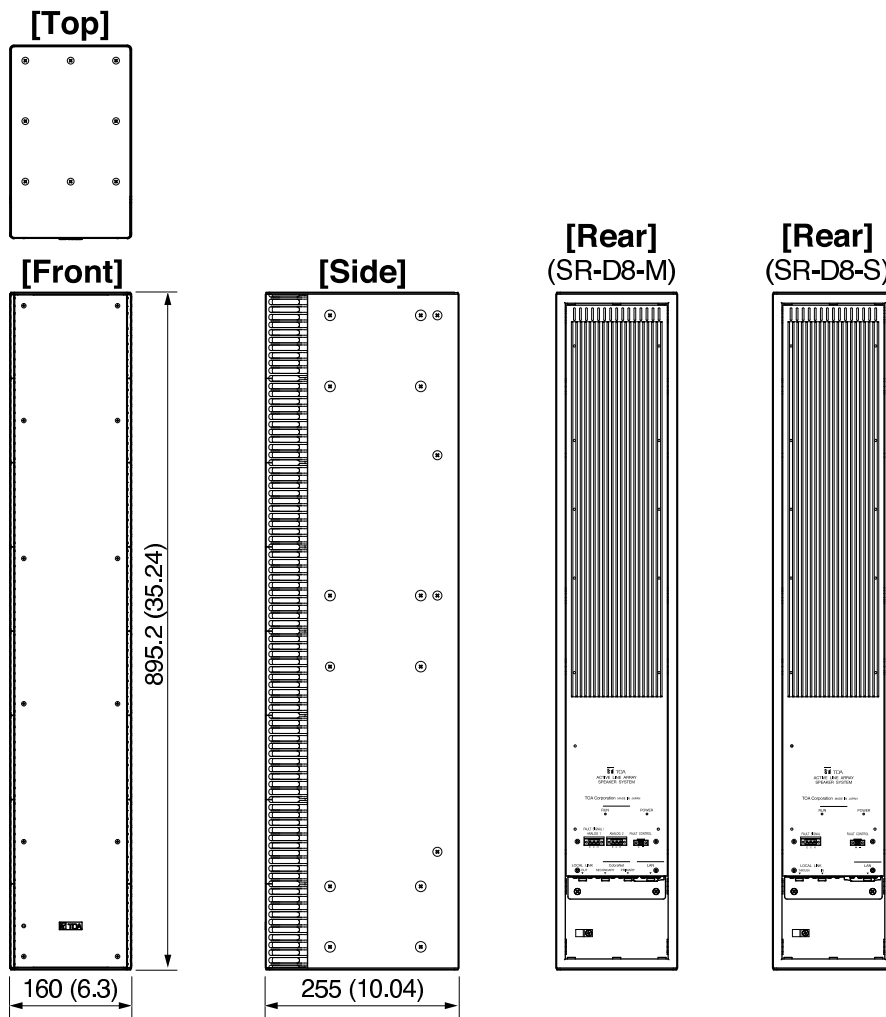

12.2. Brackets

12.2.1. SR-D8CL Wall Mounting Adapter

Unit: mm (in)

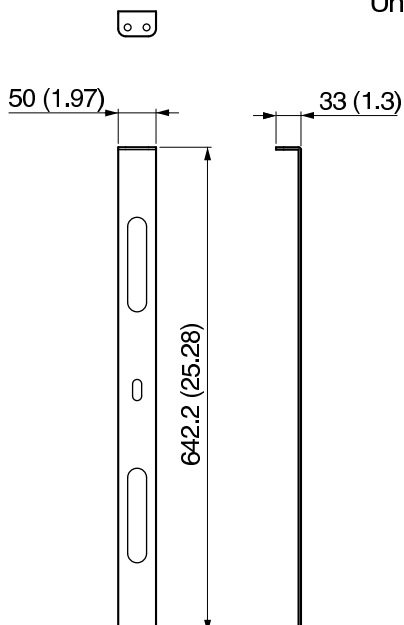

12.2.2. SR-D8CS Wall Mounting Adapter

Unit: mm (in)

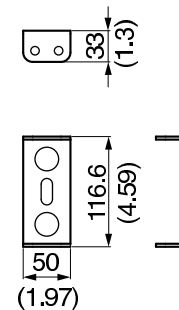

12.2.3. SR-D8EP Extension Plate

Unit: mm (in)

[L bracket]

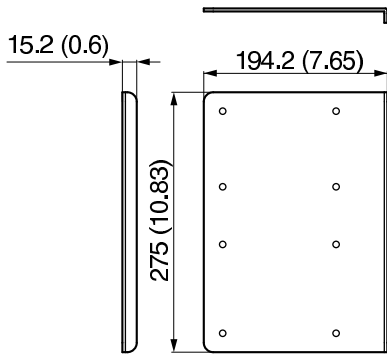

[R bracket]

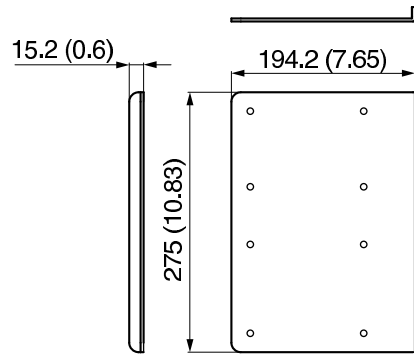

12.2.4. SR-D8WB Wall Bracket

Unit: mm (in)

[Wall bracket]

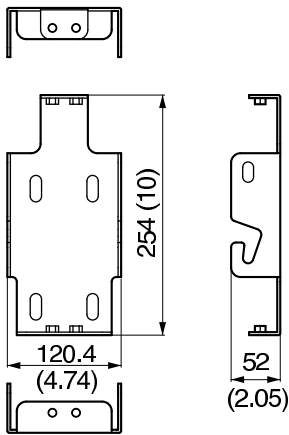

[Speaker bracket]

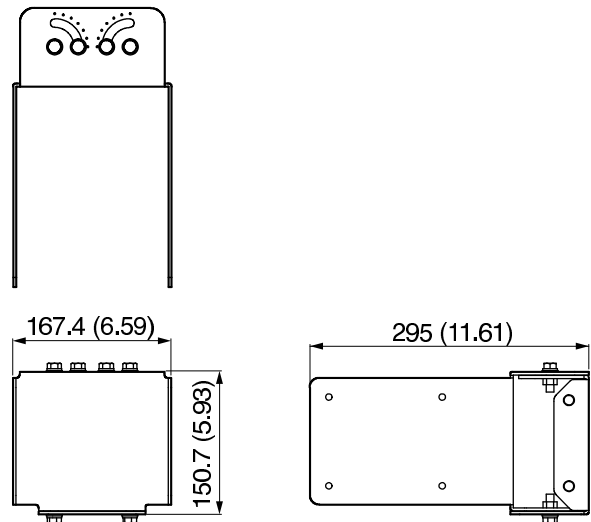

12.2.5. SR-D8HB Hoisting Bracket

Unit: mm (in)

[Hoisting bracket]

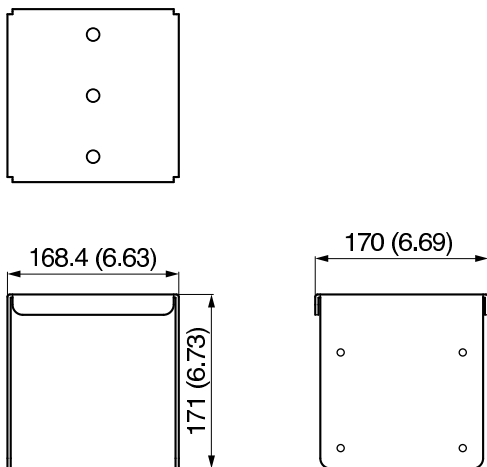

12.2.6. SR-D8FB Fixing Bar

Unit: mm (in)

[Eyebolt]

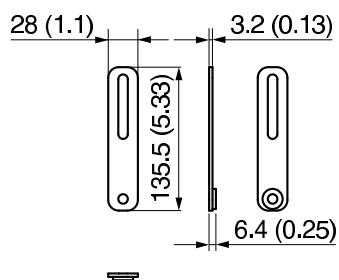
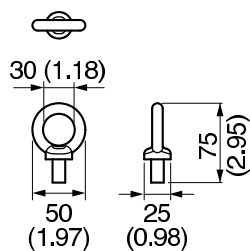

13. SPECIFICATIONS

13.1. SR-D8-M, SR-D8-S Active Line Array Speaker Systems

Version	CE	CU
Power source	220 – 240 V AC, 50/60 Hz	120 V AC, 60 Hz
Power Consumption	315 W (rated output), 72 W (based on EN standards)	320 W (rated output), 72 W (based on UL/CSA standards)
Frequency Response	130 Hz – 20 kHz	
Signal to Noise Ratio	100 dB or more (A-weighted), DSP + Digital power amplifier	
Amplification System	Class D, 8 channels	
Speaker Component	Low frequency: 10 cm (4") cone-type x 8 High frequency: 2.5 cm (1") balanced dome-type x 24	
Output	30 W, 1 channel (1% THD + N)	
Maximum SPL	93 dB SPL (A-weighted, pink noise, 30 m or 32.81 yd)	
Vertical Variable Angle	–45 to +45° (Adjustable by using the supplied SR-D8 PC Software)	
Horizontal Directional Angle	90°	
Line Input (Only SR-D8-M)	2 channels, +4 dB*, 10 kΩ, electronically-balanced, removable terminal block (3 pins)	
Sampling Frequency	48 kHz	
Network I/F		
Audio	CobraNet: 100BASE-TX, PRIMARY/SECONDARY 2 system, RJ45 receptacle (etherCON: NEUTRICK) Connection cable: Shielded twisted pair (STP) CAT 5 or higher LAN cable To be connected via the specified switching hub Max. extend distance: 100 m (109.36 yd) (connected via a switching hub) Note: This network should be completely independent of other LAN.	
Control	LAN: TCP/IP, 100BASE-TX 1 system, RJ45 receptacle (etherCON: NEUTRICK) Connection cable: Shielded twisted pair (STP) CAT 5 or higher LAN cable To be connected via the specified switching hub Max. extend distance: 100 m (109.36 yd) (connected via a switching hub)	
Communication Between Main and Sub Speakers	LOCAL LINK: TOA original digital audio transmission, RJ45 receptacle (etherCON: NEUTRICK) Connection cable: Shielded twisted pair (STP) CAT 5 or higher LAN cable	
Operating Temperature	0 to +40 °C (32 to 104 °F)	
Operating Humidity	90 %RH or less (no condensation)	
Finish	Enclosure: MDF, white, pant Front grille: Punched steel plate, white, acrylic paint	
Dimensions	160 (w) x 895 (h) x 255 (d) mm (6.3" x 35.24" x 10.04")	
Weight	21 kg (46.3 lb)	

* 0 dB = 0.775 V

Note: The design and specifications are subject to change without notice for improvement.

• Accessories

[SR-D8-M]

Power cord (2 m or 6.56 ft)	1
Removable terminal plug (3 pins)	2
Removable terminal plug (2 pins)	1
CD-ROM (containing SR-D8 PC Software)	1

[SR-D8-S]

Power cord (2 m or 6.56 ft)	1
Removable terminal plug (3 pins)	1
Removable terminal plug (2 pins)	1

13.2. Brackets

Model No.	SR-D8CS	SR-D8CL	SR-D8EP	SR-D8WB	SR-D8HB	SR-D8FB
Finish	Steel plate, white, paint					
Dimensions	See p. 33.			See p. 34.		
Weight (including accessories)	270 g (0.6 lb)	800 g (1.76 lb)	3 kg (6.61 lb)	4.7 kg (10.36 lb)	2.4 kg (5.29 lb)	150 g (0.33 lb)

Note: The design and specifications are subject to change without notice for improvement.

• Accessories

See p. 11.

Warning

This is a class A product. In a domestic environment this product may cause radio interference in which case the user may be required to take adequate measures.

FCC REQUIREMENTS

Note: This equipment has been tested and found to comply with the limits for a Class A digital device, pursuant to part 15 of the FCC Rules. These limits are designed to provide reasonable protection against harmful interference when the equipment is operated in a commercial environment. This equipment generates, uses, and can radiate radio frequency energy and, if not installed and used in accordance with the instruction manual, may cause harmful interference to radio communications. Operation of this equipment in a residential area is likely to cause harmful interference in which case the user will be required to correct the interference at his own expense.

This Class A digital apparatus complies with Canadian ICES-003.
Cet appareil numérique de la classe A est conforme à la norme NMB-003 du Canada.

Traceability Information for Europe

Manufacturer:
TOA Corporation
7-2-1, Minatojima-Nakamachi, Chuo-ku, Kobe, Hyogo,
Japan

Authorized representative:
TOA Electronics Europe GmbH
Suederstrasse 282, 20537 Hamburg,
Germany

