



# MUSIC SYSTEM

for BACKGROUND  
for FOREGROUND



# Enhancing the customer experience

Enhance the customer experience with a sound systems for the retail environment.



## Ambiance created through Background or Foreground music, Plus, reliable communications.

A sound system is essential in creating a store's ambiance. A retail store wants to create an environment that is pleasing to their customers. A sound system that provides background music offers your customer a relaxed environment putting customers at ease, and motivating them to browse and purchase your products.

A sound system plays a pivotal role in creating a lively atmosphere by providing foreground music for performances by bands, lively music for dancing and other events.

Yet there is more to sound systems than music. They also play a role in broadcasting information, fulfilling the need to reliably convey up-to-date and useful information to your customers and staff. You can also use a sound system to provide advertising or emergency messages that have pre-recorded content relayed at appropriate timing.

TOA provides retail stores with a range of solutions based on the kind of broadcasting required (such as background music or paging), the size of the store, and its layout.

## Featured Products

# Digital Mixer Amplifier

## A-5000 Series



The TOA A-5000 series offers the ability to control your music just the way you want it! Featuring built in digital signal processors (DSP) that boast high efficiency and durability along with digital amplification for long-term use. This unit has precise EQ settings via PC for optimal performance and security. Available in 60 and 120 Watt versions making it an ideal choice for small to medium restaurants and retail establishments.

- 1U-half size compact and simple hardware for easy setting
- Hi-/Low-Z speaker connection
- 60W and 120W models
- 2 x mic/line inputs with mute
- Intuitive GUI software for sound optimization
  - 5-band Parametric Equalizer for each input and output
  - Remote Master Volume Control
  - Mute (Mic 1 priority: Manual mute)
  - Compressor for each input 1 and 2
- 10 band selectable DSP filters for output (HPF/LPF/PEQ selectable, 5 more filters)
- 15 selectable TOA Speaker EQ presets
- FBS (Feedback Suppressor) for input CH 1 & 2

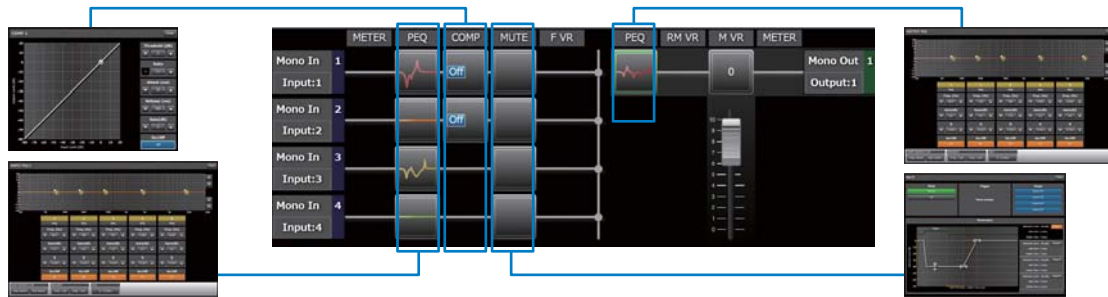
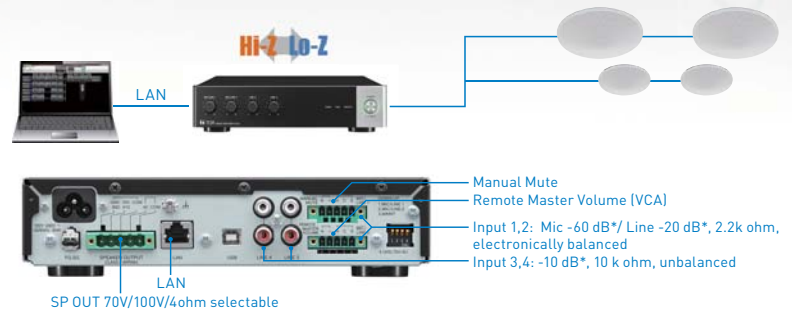

## Featured Products

# Matrix Amplifier

## MA Series



TOA's MA-725F matrix amplifier and MM-700F is all-in-one solution for multi-channel or multi-zone applications combining a 6x4 audio matrix, DSP and 4ch Class-D amplifier(\*) into one chassis. It is equipped with 4 independent line inputs, 2 MIC/LINE priority inputs. Each output has independent DSP preset adjustment with input source matrix selection. It features high power (250Wx4 @ 70V/100V)(\*) and various inputs capabilities. Its wide range of applications include general or emergency announcement and background music for restaurants, pubs, retail stores, schools, offices, etc.

(\*)MA-725F only

### Features

- 4 stereo-summing line inputs with matrix routing to 4 amplifier outputs.
- Each line input has input level adjustment and assign restriction setting for each output to prevent routing selection.
- 2 priority MIC/LINE inputs with different priority level for paging or other pre-recorded source which can override the selected line input on assigned output channels.
- Each priority input also has input level, mute sensitivity and mute hold time adjustments.
- Each output channel is equipped with 250W Class-D amplifier at 70V/100V output voltage selectable with independent DSP preset selection and 50Hz HPF for the protection of connected speakers.(\*)
- Selectable DSP preset selections include general EQs, like Loudness curves, TOA speaker EQs and crossover settings to be used with sub-woofers.

- Each output channel also has auxiliary line output to deliver audio to other systems.
- This matrix doesn't need any PC programming or network connection for setup at site. (Maintenance purpose only)
- Optional wall mount remote control, WP-700 can be connected via CAT-5 straight LAN cable to control the line input selection and output volume of each output.
- Class-D amplifier has various protection features against over current, high temperature and short circuit of speaker lines at each output channel.(\*)
- Power supply with Power Factor Correction for reduced power consumption and world-wide operating range.(\*)
- Option: WP-700-AM Wall Panel

(\*) MA-725F only



WP-700-AM



## Large Scale Multi Zone BGM/FGM Distribution System

An example of a large bar/restaurant with six listening zones: Multiple audio sources and announcements can be made at the same time. Using a remote controller, the particular audio source is selected for each zone, and volume adjustments are made. F Series Speakers deliver excellent sound to each area.

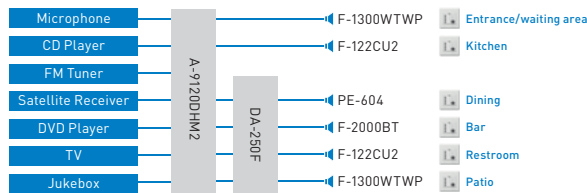
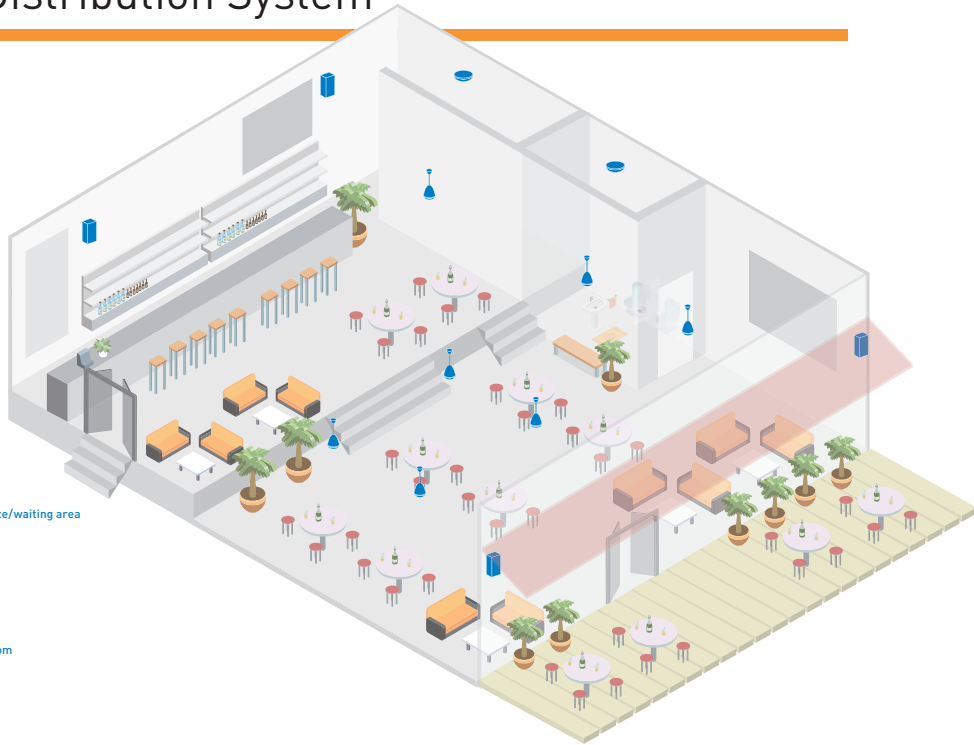

## Mid Scale Single Zone BGM/Paging Distribution System

A low-cost solution for mid-size supermarkets, with two-level priority broadcasting for paging, advertising, and background music. The BG-2000 series is a simple amplifier that is set up and ready to go with nothing more than the volume setting. Not only that, but all input/outputs have removable terminal blocks for quick and easy installation.

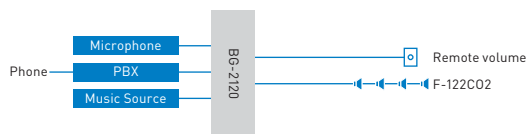
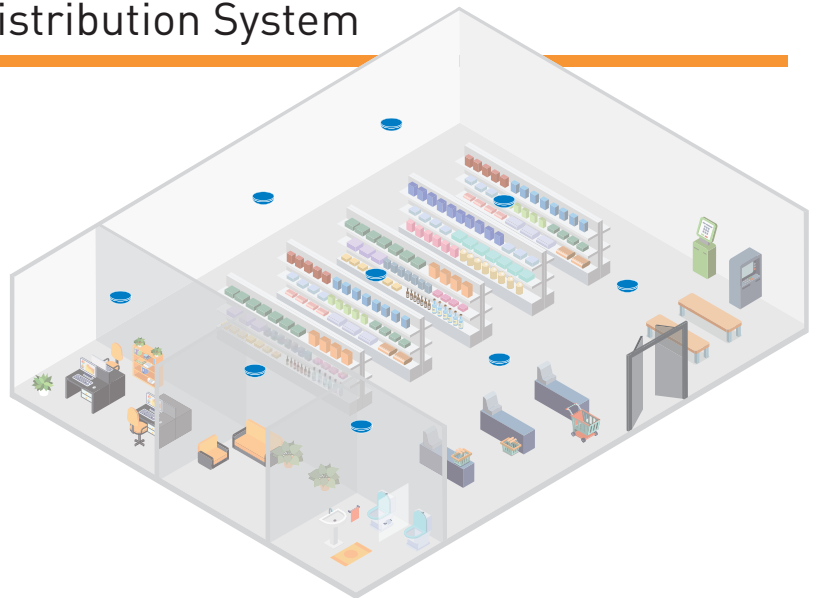



## Mid Scale Single Zone BGM/Paging Distribution System

The following is a solution for a single-floor clothing store. Background music, paging and advertising announcements are possible using priority broadcasting. The TOA A-5000 series is a digital mixer amp with DSP, in a compact, half-size body. Equalizer settings can be fine-tuned using the graphic user interface, making the TOA speakers perform at their very best and creating a rich soundscape. Optimized for mid-size stores that care about sound quality.

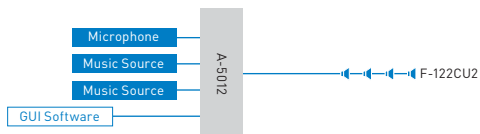

## Simple Single Zone BGM Distribution System

This simple background music system is designed for small shops. It is easily installed, and is configured in a way that is inexpensive to operate. Two-level priority settings can be made for background music and announcements. All input/outputs have removable terminal blocks for quick and easy installation.

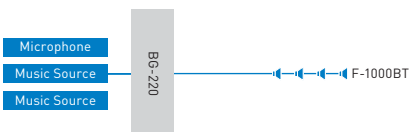
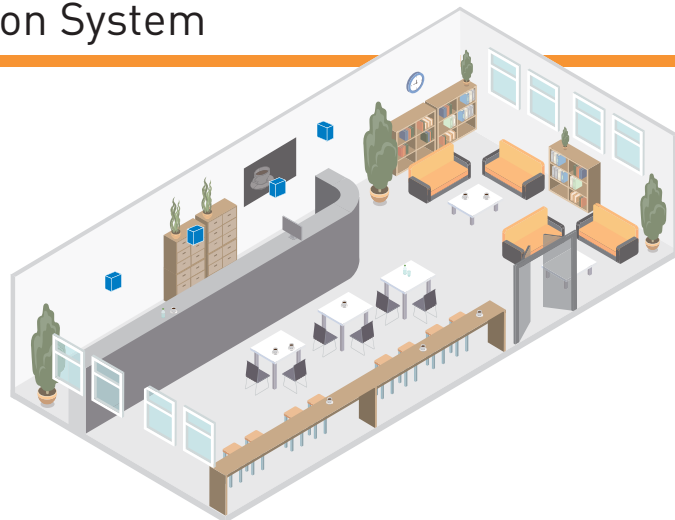

# Lineup: Amplifiers

## Mixer Amplifier A-706 / 712 / 724

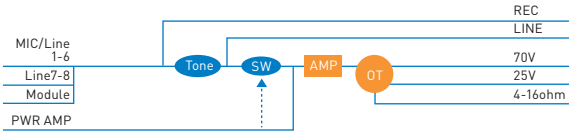

## Power Amplifier BA-235 / 260



## Mixer Amplifier BG-220 / 235

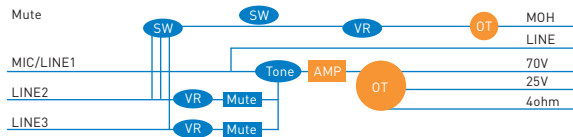

## Mixer Amplifier BG-2035 / 2060 / 2120 / 2240D

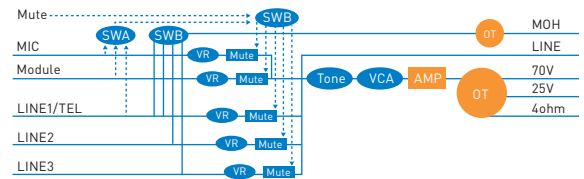

## Modular Digital Matrix Mixer/ Amplifier A-9060DHM2 / 9120DHM2 / 9060SM2 / 9120SM2 / 9240SHM2 / M-9000M2

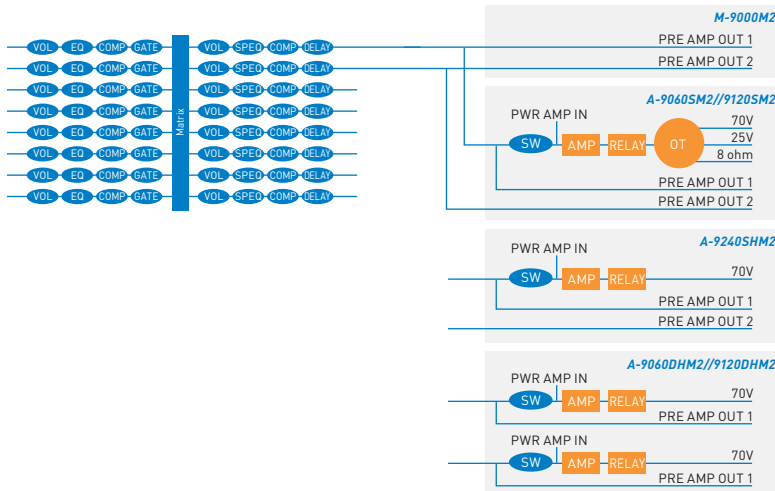

- Flexible modular design - up to 8 mic/line inputs and 8 outputs
- Intuitive GUI software
- 34 TOA Speaker EQ Presets
- Up to 16 flush-mount remote panels connectable
- 32 scene memories and 32 paging memories

## Multi-Channel Digital Power Amplifier DA-250FH



- Light and compact body. Independent power supply for each channel ensures high efficiency and reliability.

## Amplifier Comparison Chart

Model	Power	Inputs	Paging	Phantom Power	Priority Mute	Outputs	Unit Size	Additional Features
A-706/712/724	60W/120W/240W	8 + 1 (Module)	☑	Input 1-6	Auto/Manual	1 Main, 1 Line Out	2U	EQ: Treble/Bass
MA-725FH	250W x 4	6	☑	N/A	Auto/Manual	4 Main, 4 Line Out, 1 MOH	2U	EQ: Selectable 16 presets x4 banks 4 Remote Controls for Volume and Source Selection
MM-700F	Mixer only	6	☑	N/A	Auto/Manual	4 Main, 1 MOH	2U	EQ: Selectable 16 presets x4 banks 4 Remote Controls for Volume and Source Selection
BG-2035/2060/2120/2240D	35W/60W/120W/240W	5	☑	MIC Input	Auto/Manual	1 Main, 1 MOH	2U	EQ: Treble/Bass
BG-220/235	20W/35W	3	☑	N/A	Auto/Manual	1 Main, 1 MOH	2U half	EQ: Treble/Bass
BA-235/260	35W/60W	1		N/A	N/A	1 Main, 1 MOH	2U half	EQ: Treble/Bass

## Lineup: Loudspeakers

### F Series Wide-Dispersion Ceiling Speakers

Expanded listening area coverage thanks to the extra-wide dispersion characteristics makes it possible to utilize fewer speakers to cover a desired area, making these speakers cost-effective.



### Wall Mount Box Speakers

2-way bass-reflex speaker with transformer for Hi/Lo (100V, 70V, 8 ohms) impedance with 30W of rated output. Easy to install with equipped bracket. IP-X4 rated.



### Projection Speakers

Stylish and outstanding design inspired by the finest lighting fixtures that blend into any interior design. Flexible speaker direction adjustment with accessory brackets.



### HX-5 Series Compact Array

Compact modular design includes four preassembled modules with four LF drivers and twelve HF dome tweeters. Dispersion angle adjustable to 60, 45, 30, and 15 degrees.



### PC-580 Ceiling Mount Speaker

Designed to fill the need for a high-performance, cost effective ceiling speaker for use in everyday Paging and Background Music requirements.



### CS Series Wide Range Horn Speakers

Wide-range paging speakers for voice paging, background music and tone signaling distribution. Weatherproof polyurethane resin paint and impact-proof lightweight ABS resin enclosure.



### F Series Wide-Dispersion Speakers

Two-way bass-reflex design. Wide-dispersion characteristics provide better sound coverage and improved tonal response. Included accessory brackets expand options for installation. 4", 5" and 8" models. Black/white and weather-proof versions available.



### Pendant Speakers

Stylish and outstanding design inspired by the finest lighting fixtures. Ideally suited for such venues as shopping malls and restaurants with high ceiling.



### H series Interior Design Speakers

Sleek, stylish appearance blends well with modern architecture for background/foreground music and paging systems. Minimum reflection design reduces sound wave reflections typical of conventional bracket-mounted "box" type speakers.



### FB-120 Subwoofer

Designed for use in conjunction with TOA HX-5 series or other full-range speakers. Wide frequency range/ 600W continuous program/ Sensitivity (1W, 1m): 90 dB.



### Line Array Type H

Designed to minimize reflection and feedback, while supporting uniformly dispersed sound and intelligible speech. Suitable for environments prone to reverberation. Slim 84 mm (3.3") wide enclosures with high-quality 70 mm (2.8") full-range speaker units.



### Coaxial Line Array Speakers

Large-diameter woofer provides wide dynamic bass sound. High intelligibility and attractive design provide a comfortable area according to your needs.



## OPTIONS

Alongside amplifiers and speakers, TOA has an extensive line-up of equipment for background music and foreground music applications. Visit our website to learn more.

[www.TOAcanda.com](http://www.TOAcanda.com)



Digital Ambient Noise Controller



AM/FM Synthesizer Tuner



UHF Wireless System



TOA Canada Corporation

Tel: 800-263-7639

[www.TOAcanda.com](http://www.TOAcanda.com)

Specifications are subject to change without notice.

(1610) 833-61-100-27-00-v2