



DP-L2 DIGITAL AMBIENT NOISE CONTROLLER



***Digital audio processor adjusts BGM/announcement
sound volume to match changes
in listening area noise levels.***



Consistently Pleasant-sounding BGM and

The TOA DP-L2 Digital Ambient Noise Controller is the easy, automatic solution to the problem of keeping BGM and announcements audible and understandable when the ambient noise levels at an airport check-in counter or boarding gate, or a shopping mall, restaurant or pub, are higher because a large number of people are present. Furthermore, the DP-L2 also works to keep music and information audio from reaching levels that are irritating to customers and staff when the surrounding ambient noise levels are not so high.

Automatic and Accurate Input and Output Sound Level Adjustment

The DP-L2 is a digital audio processor with an ambient noise control (ANC) function that makes automatic changes in its output sound levels depending on the amount of surrounding noise, and an automatic level control (ALC) function that automatically adjusts the input signal level so it is appropriate at all times. BGM and announcements remain audible and understandable at all times, with no annoying loudness for customers and employees.

Output Excluded from Ambient Noise Sensing

The ambient noise sensor microphone enables accurate measurement of BGM/announcement listening-area noise levels. In addition, for complete accuracy, a DP-L2 feature exclusive to TOA automatically separates the unit's own output from the calculation of the ambient sound level, instead of just mixing all sound sources together, meaning that the output is not detected as noise. Additionally, a monitoring feature makes it possible to check the sound collected by the ambient noise sensor microphone.



DP-L2



Information for Customers and Employees.

Easy, Quick Installation and Simple Operation

The DP-L2 fits on a standard 1U size rack, so there is no time-consuming, complex installation procedure. All functions can be easily set from the unit's front panel, thanks to an LCD (liquid crystal display), keys and knobs.

A key-lock function prevents accidental incorrect front-panel key settings, and there are also front-mounted LED meters for input/output signal levels, as well as ALC and ANC levels.



System Example (When broadcasting is done via a microphone while BGM is on)

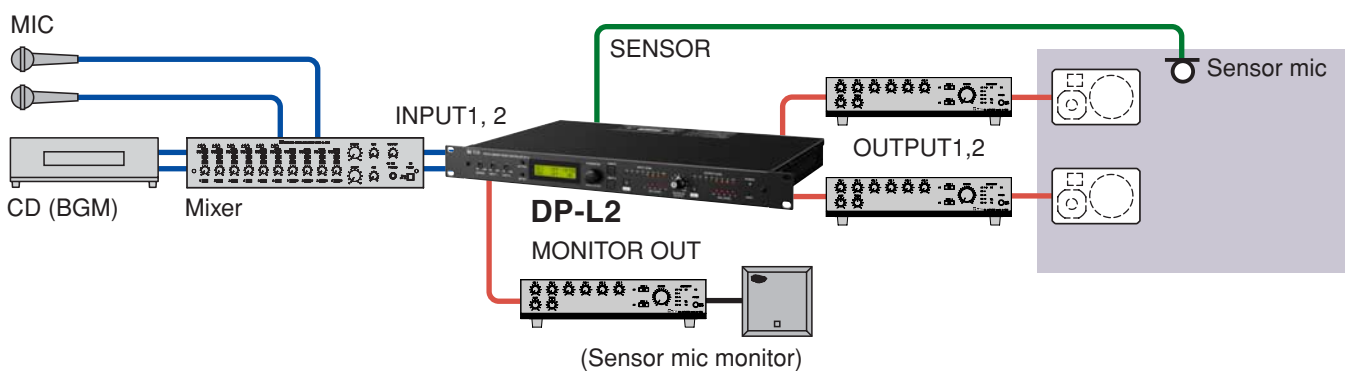

SPECIFICATIONS

* 0dB = 0.775 V

DP-L2		
Power Source	AC mains, 50/60Hz	
Power Consumption	20W	
Frequency Response	20 — 20,000Hz, ±1dB	
Sampling Frequency	48kHz	
Dynamic Range	Over 108dB (IHF-A weighted)	
Distortion	Under 0.006%, 1kHz, +4dB* input/output (20 — 20,000Hz BPF)	
Input	Sensor input (Ambient noise sensor microphone input): +4/-48dB* changeable, 10kΩ, electronically-balanced, removable terminal block (4 pins), phantom power (+15V DC, can be turned on or off with Phantom switch) with +15V DC terminal Input 1, 2: +4/-8/-20dB* changeable, 15kΩ, electronically-balanced, removable terminal block (3 pins)	
Output	Monitor output: +4dB*, 600Ω, electronically-balanced, removable terminal block (3 pins) Output 1, 2: +4dB*, 600Ω, electronically-balanced, removable terminal block (3 pins)	
A/D Converter	24 bit	
D/A Converter	24 bit	
Signal Processing	Automatic Level Control Function	Level meter (4 LED meters), Automatic input signal level control function. Automatic input sensitivity setting function: +4/-8/-20dB*, Noise gate level setting: -99 to -3dB
	Ambient Noise Control Function	Level meter (4 LED meters), BGM/Announce level control function, Automatic sensor input reference level measuring function, Sensor input reference level fine adjustment function, Maximum output signal level control: -15 to 0dB, Minimum output signal level control: -18 to -3dB, Sample time setting: 10 s, 20 s, 30 s, 1 min, 5 min Gain ratio setting (Ambient noise; Output signal level) 6: 3, 5: 3, 4: 3, 3: 3, 3: 4, 3: 5, 3: 6, Ambient noise measuring frequency setting: 20 — 20,000Hz, 3 points
	Maximum Output Signal Level Control Function	-12, -6, 0, +4, +6, +12, +18, +24dB*
	Input Level Indicator	8 LEDs indicator
	Output Level Indicator	8 LEDs indicator
Other Feature	Phantom power switch (sensor input), Key lock function, Ground lift switch (INPUT 1, INPUT 2), Input/Output bypass function in power off	
Operating Temperature	0°C to +40°C	
Operating Humidity	Under 90% RH (no condensation)	
Finish	Pre-coated steel plate, black, 30% gloss	
Dimensions	482 (W) × 44 (H) × 303 (D)mm	
Weight	3.7kg	
Accessory	Removable terminal plug (4 pins) × 1, Removable terminal plug (3 pins) × 5	

Note: Prepare ambient noise sensor microphone separately.