

### Installation

#### Back cover installation

Regarding the size of back cover, use the cement to fix the back cover in the wall, make sure the path for power and Ethernet has been reserved.

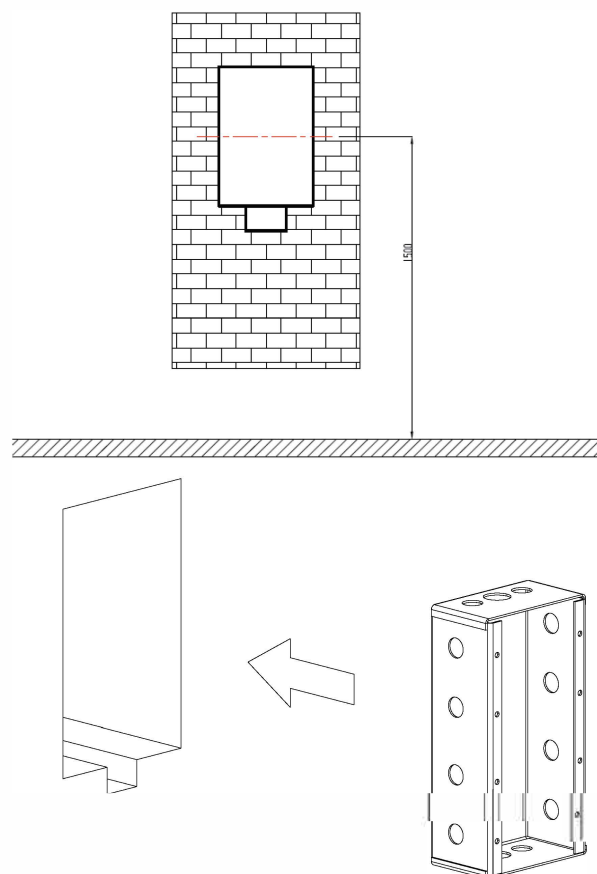

### Connect to the power and Internet

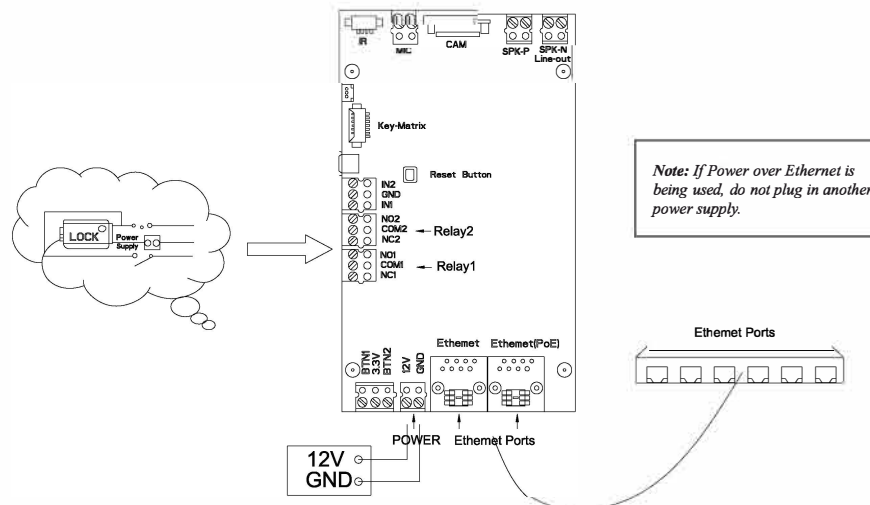

### Fix the panel with screws

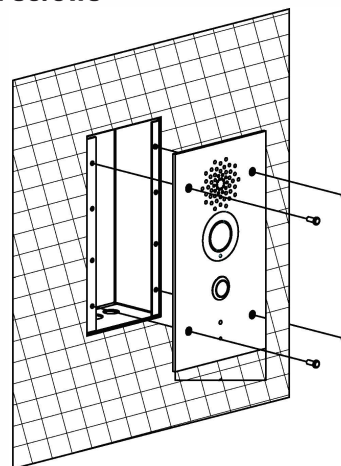

### Configuration

1. Access the Web UI: Input the IP address into browser to configure the phone. The default IP address is 192.168.1.102.
2. Account Registration: On web UI, go to the path: **Account -> Basic** to register an account and fill in the account information. (*Please refer to user manual for more information*)
3. Configure the Push Button: On web UI, go to the path: **Intercom -> Basic -> Push Button** to configure the call number.
4. Configure the DTMF code: On web UI, go to the path: **Intercom -> Relay&Input -> Relay** and choose the DTMF code number in corresponding area.

### IP Announcement

1. While the device startup normally, hold the call button for several seconds after LED light turns blue, voice system will enter IP announcement mode.
2. In announcement mode, the IP address will be announced periodically.
3. Press Call Button again to exit the announcement mode.
4. In announcement mode, phone announces "IP 0.0.0.0" if no IP address is gained.

### Operation

#### Make a call:

1. Press the call button to call a SIP Multimedia Station, video call is only for N-SP80VS1.
2. During the talk, called party can press predefine DTMF code number to open the door.

#### Receive a call:

N-SP80VS1/80AS1 supports Auto Answer by default. Incoming call from indoor device will be answered automatically.

### LED Status Information

LED Status	Description	
Blue	Always on	Normal status
	Flashing	Calling
Red	Flashing	Network is unavailable
Green	Always on	Talking on a call
	Flashing	Receiving a call
Pink	Flashing	Firmware upgrading

Note: For more LED settings, please refer to N-SP80VS1/80AS1 web interface.

### Unpacking

Please make sure the package contains the following items:

- N-SP80VS1/N-SP80AS1 x 1
- Screw x 4
- Screwdriver x 1
- Back cover x 1 (Optional)

### Product Overview

